

指明集团有限公司

ZHIMING GROUP CO.,LTD.

地址(Add)：浙江省乐清市柳市镇车站路303号

邮编：325604

电话(Tel)：86-577-6180888 62897168

传真(Fax)：86-577-62896168

http://www.zmgs.com

E-mail：zmgroup@126.com



® 系注册商标，属指明集团有限公司(ZHIMING GROUP CO.,LTD.)所有
指明集团(ZHIMING GROUP)版权所有 采用环保纸印刷

▲ 本广告资料由指明集团企业印刷，仅用于展示本企业系列的相关资料。本手册只汇编了指明集团部分代表性产品，指明集团部分产品正在研发，升级中或采用更新的生产工艺改进本手册有关内容，或对本手册的印刷错误及相关资料信息进行必要的改进或更改时，恕不另行通知。若您有任何疑问，敬请来电咨询！



指明集团微信

指ZHIMING明

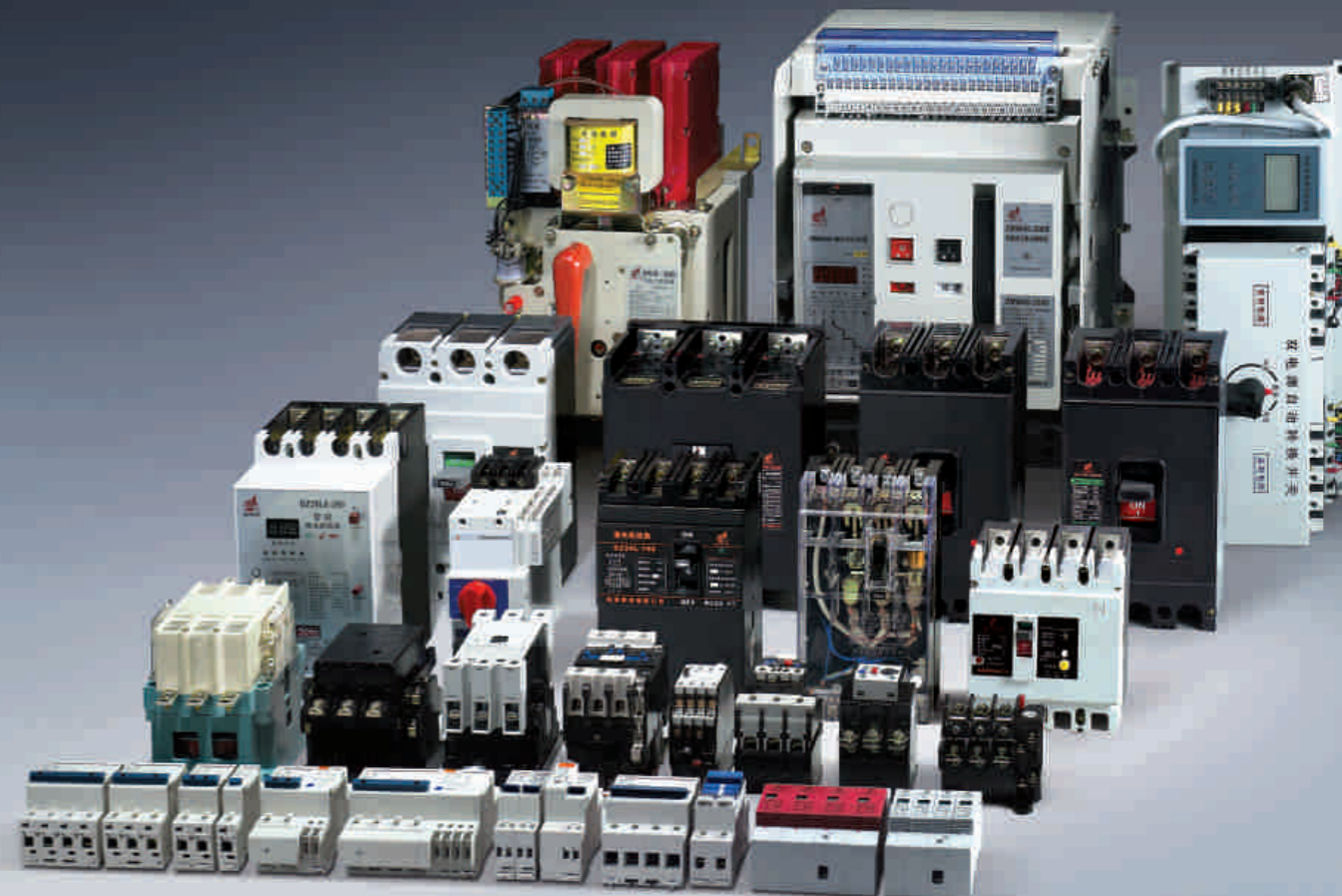

产品选型目录
PRODUCT CATALOG

2017 高低压电器系列

ZHIMING GROUP

指明集团有限公司
ZHIMING GROUP CO.,LTD.

指明集团与您共同成长
Zhiming Group Appliance grows
up with you



董事长：王如可

集团简介 GROUP BRIEF

指明集团有限公司地处中国电器之都 - 浙江省乐清市，成立于1999年的金秋时节，注册资金壹亿壹仟捌佰万元，是一家全国性无区域企业，并被认定为浙江省高新技术企业，为国家电网公司合格入围供应商。

集团公司专业生产高低压电力电容器，智能集成电容器，电容器投切开关，无功补偿控制器，无功补偿装置系列，单、三相电能表，三相多功能电能表，智能型多用户电能表等高、低压电器元件产品。公司通过自主与合作研发等途径，不断加快产品的更新换代及开发，众多产品质量达到了国内领先水平和国际标准。集团公司先后通过了ISO9001质量管理体系认证、ISO14001环境管理体系认证、OHSAS18001职业健康安全管理体系认证，“指明”牌产品通过了中国质量认证中心的CCC、CQC等产品质量体系的认证，公司也多次被评为省级“高新技术企业”、“科技型企业”、“诚信民营企业”、“信用管理示范企业”等荣誉称号。公司技术力量雄厚，先后获得多项产品技术专利，公司研发中心被认定为“温州市企业技术研究开发中心”。

集团公司在满足国内客户需求的同时，产品还远销东南亚、中南美洲、俄罗斯、中东地区等地，获得广大客户的一致认可。公司将以“质量第一、优质服务、积极进取”为宗旨，诚邀广大国内外朋友携手并进、共创辉煌！

ZHIMING GROUP CO., LTD. located at Yueqing, Zhejiang, the Electric city, was established in the Autumn of 1999, the registered capital RMB 118 Million Yuan, one the unlimited regional enterprise in China, now classified as Zhejiang Hi-tech Enterprises, one of the supplier member of China State Grid.

The group professionally produces high and low voltage power capacitors, intelligent integrated capacitor, capacitor switch, reactive power compensation controller, reactive power compensation devices, single, three phases energy meters, three-phase multi-functional meters, intelligent energy meter for multiple users and etc. through self-research and cooperation, we continued developing new products, many products have reached up to domestic latest level and complied with international standards. Our group has awarded ISO9001, ISO14001, and OHSAS18001 certificates, ZHIMING brand products passed the attestation of CCC, CQC issued by China Quality Attestation Center. Our company had achieved the titles of Hi-tech Enterprises, Technical Enterprise, Private Credit Enterprise, Typical Enterprise of Credit Management and etc. Our company occupied powerful technical strength, attained many technical patents. our research center is classified as Wenzhou Technical Research Center.

Our products not only supply for the demand of domestic customers, also exported to Southeast Asia, Middle America, Russia, Middle east and etc, won the wide acceptance from the users. we would insisted on the tenet of "Quality first, Best Services, Active Striving", welcome the domestic and foreign friends to cooperate and build a splendid future.

资质证书 QUALIFICATIONS & HONORS



目录



DZ47-63 / DZ47-63H系列小型断路器	01-02
DZ47-125系列小型断路器	03-04
ZML7系列小型断路器	05-06
DZ47-63DC系列交直流用小型断路器	07-08
DZ30-32小型断路器	09-10
ZMB-1S-63带分励脱扣器小型断路器(卡式电表专用开关)	11-12
DZ47LE-63系列剩余电流动作断路器	13-14
DZ47LE-125系列剩余电流动作断路器	15-17
DZ30LE-32系列剩余电流动作断路器	18-19
ZM30LE-63系列剩余电流动作断路器	20-21
HL30-100系列隔离开关	22
ZMH3-100系列隔离开关	23
AC30模数化插座、多功能插座	24
ZMQ3/4/5-G系列自复式过欠压保护器	25-27
ZMP1系列电涌保护器	28-29
ZMP4系列电涌保护器	30
ZMP1-100/120/150系列电涌保护器	31
ZMP11-5/25/50一级电涌保护器	32-34
ZM-PV光伏电涌保护器	35
SZM1系列塑壳式断路器	36-38
SZM1E系列智能型塑壳式断路器	39-40
SZM1(NS)系列塑壳式断路器(电子式)	41-42
ZMM10系列塑壳式断路器	43-44
DZ15系列塑壳式断路器	45
DZ15D型多功能自动保护开关	46
DZ20系列塑壳式断路器	47-48
SZM1LE系列漏电断路器	49-50
SZM1(NSLE)系列剩余电流动作断路器	51-52
ZMM10LE系列漏电断路器	53
DZ15LE系列漏电断路器	54-55
DZ15LED电子式漏电断路器/断相过流自动保护开关	56
DZ20L系列漏电断路器	57-58
JD6- 鉴相鉴幅剩余电流保护器	59
ZMM20LE系列剩余电流动作断路器	60-61
ZMKB0系列控制与保护开关电器-基本型	62-65
ZMQ2E系列双电源自动转换开关	66-68
ZMQ2M系列双电源自动转换开关	69-70
ZMQ2系列双电源自动转换开关	71-74
ZMQ5系列双电源自动转换开关	75-79
DW15系列万能式断路器	80-82
DW17系列万能式断路器	83-90
ZMW45智能型万能式断路器	91-96
ZMW50-1000智能型万能式断路器	97-105
ZMW2-1600智能型万能式断路器	106-115
JR36系列热继电器	116
JRS1, JR28系列热继电器	117
CJT1系列交流接触器	118
CJ20系列交流接触器	119-120
CJ40系列交流接触器	121-122
CJX1系列交流接触器	123
CJX2系列交流接触器	124-125
CJX8(B)系列交流接触器	126-127
HD/HS系列开启式刀开关及刀形转换开关	128-134
HD11F/HS11F系列保护型开启式刀开关	135-136
HR3系列熔断器式隔离开关	137-139
HR5系列熔断器式隔离开关	140-141
HR6系列熔断器式隔离开关	142-143
LW5D万能转换开关	144-146
LW12万能转换开关	147
QZB系列自耦变压器	148
JJ1(XJ01), JJ1B系列自耦减压起动柜	149
QX4系列星三角起动柜	150
XQP系列频敏起动柜	151
ZMR8电机软起动器	152-153
ZMR8-G电机软起动器/在线式智能电机软起动柜	154
HY/Y系列金属氧化物避雷器	155-157
VS1-12 户内高压真空断路器	158
VS1-12 户内永磁高压真空断路器	159
ZW8-12/630-20户外高压真空断路器	160
ZW32-12户外真空断路器	161-162
ZW32-12户外永磁真空断路器	163-164
FZN25-12 户内真空负荷开关-熔断器组合电器	165-166
FZN21-12 户内真空负荷开关-熔断器组合电器	167-169
FN12-12 户内高压负荷开关-熔断器组合电器	170-171
FN7-12 系列户内高压负荷开关及熔断器组合电器	172-173
FN5-12 系列户内高压负荷开关及熔断器组合电器	174
GN19-12 型系列户内高压隔离开关	175
GW9 系列户外高压隔离开关	176



DZ47-63/DZ47-63H 系列小型断路器 Series Miniature Circuit Breaker



主要参数及技术性能 Main technical data

主要规格:

- 按额定电流 I_n 分: 1A、3A、6A、10A、16A、20A、25A、32A、40A、50A、63A。
- 极数:
 - a. 单极;
 - b. 二极;
 - c. 三极;
 - d. 四极。
- 按断路器瞬时脱扣的型式分:
 - a. C型 (5 I_n ~10 I_n);
 - b. D型 (10 I_n ~16 I_n)。

主要技术参数:

- 额定运行短路分断能力 (见表1、表2);
- 机械电气寿命
 - a. 电气寿命: 不低于4000次;
 - b. 机械寿命: 不低于10000次。

Main Specifications:

- Rated current (I_n): 1A, 3A, 6A, 10A, 16A, 20A, 25A, 32A, 40A, 50A, 63A.
- Poles:
 - a. 1 pole;
 - b. 2 poles;
 - c. 3 poles;
 - d. 4 poles;
- Instantaneous tripping circuit breakers:
 - a. C type (5 I_n ~ 10 I_n);
 - b. D type (10 I_n ~ 16 I_n).

Main technical data

- Rated short-circuit breaking capacity (see table 1, 2)
- Mechanical and electrical life
 - a. Electrical life: 4,000 times;
 - b. mechanical life: 10,000 times.

DZ47-63(C)型: 表1 Table1

额定电流 Rated current (A)	极数 Poles	电压 Voltage (V)	通断能力 Breaking capacity (A)
C1~C40	1	230/380	6000
C1~C40	2,3,4	380	6000
C50~C63	1	230/380	6000
C50~C63	2,3,4	380	6000

DZ47-63(D)型: 表2 Table2

额定电流 Rated current (A)	极数 Poles	电压 Voltage (V)	通断能力 Breaking capacity (A)
D1~D63	1	230/380	4000
D1~D63	2,3,4	380	4000

适用范围 Application

DZ47-63小型断路器, 主要用于交流50Hz/60Hz, 额定电压至380V, 额定电流至60A的线路中起过载、短路保护作用, 同时也可以在正常情况下不频繁地通断电器装置和照明线路。

符合标准: GB10963.1, IEC 60898-1。获得CCC, CE认证。

The DZ47-63 series miniature circuit breaker is applicable to the circuit an alternating current of 50Hz, rated voltage of 230/380V, and rated current up to 63A for overload protection and short circuit protection and also for not-frequent operational transformation in the circuit under normal condition. The product meets the standards of GB10963.1, IEC60898-1, Obtained CCC, CE certification.

型号及其含义 Code and implication

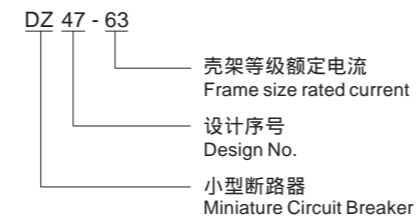

正常工作条件 Normal operating conditions

- 环境温度: -5 ~ +40; 24h内平均值不超过35。
- 海拔高度: 安装地点的海拔不超过2000m。
- Ambient air temperature: -5°C~+40°C, the mean value is no greater than +35°C within 24 hours.
- Altitude: not higher than 2000m for the installation site.

过电流保护特性(见表3) For the over current protection characteristics (see table3)

表3 Table3

序号 No.	脱扣器额定电流 I_n (A) Rated current	起始状态 Initial state	试验电流 Test current	规定时间 Time limit	预期结果 Expected result	备注 Remarks
a	1~63	冷态 Cold state	1.13 I_n	t 1h	不脱扣 No tripping	
b	1~63	紧接着a项试验后进行 Right after test number a	1.45 I_n	t < 1h	脱扣 Tripping	电流在5s内稳定的上升至规定值 The current is rising within 5s
c	1~32	冷态 Cold state	2.55 I_n	1s < t < 60s	脱扣 Tripping	
	40~63	冷态 Cold state	2.55 I_n	1s < t < 120s	脱扣 Tripping	
d	1~63	冷态 Cold state	5 I_n	t 0.1s	不脱扣 No tripping	C型 C type
e	1~63	冷态 Cold state	10 I_n	t < 0.1s	脱扣 Tripping	C型 C type
f	1~63	冷态 Cold state	10 I_n	t 0.1s	不脱扣 No tripping	D型 D type
g	1~63	冷态 Cold state	16 I_n	t < 0.1s	脱扣 Tripping	D型 D type

脱扣特性曲线图(见图1)。Characteristic curve(See Fig.1)

限流特性(见图2)。Limiting characteristics(See Fig.2)

DZ47-63小型断路器具有高限流能力, 从而最大限度地限制了短路所造成的破坏性能。

DZ47-63 miniature circuit breaker with high current limiting capability, thereby limiting the maximum short-circuit caused by the destructive energy.



图1 C型 Fig.1 C type

图2 D型 Fig.2 D type

- 接线: 适用25mm以下导线连接 (见表4), 扭矩2.0N·m
Wiring: good for connection of leads of less than 25mm² (see table4);
Wiring method: screw hold-down with a torque of 2 N·m

表4 Table 4

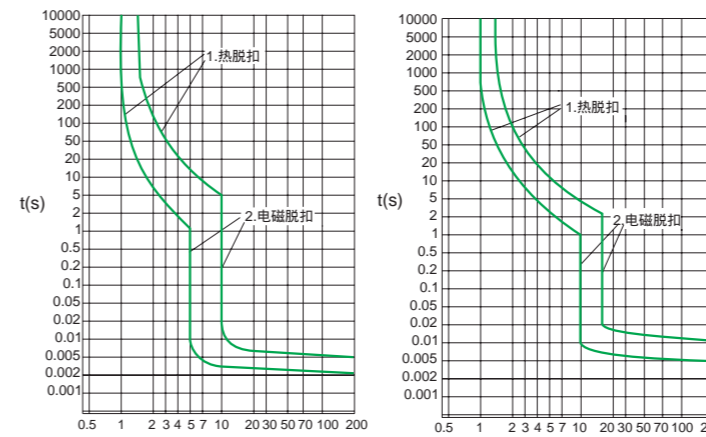
额定电流 I_n (A) Rated current	铜导线标称截面积(mm ²) Nominal cross-sectional area of the copper conductor
1~6	1
10	1.5
16、20	2.5
25	4
32	6
40、50	10
63	16

外形及安装尺寸 Outline & installation size

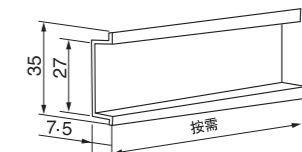
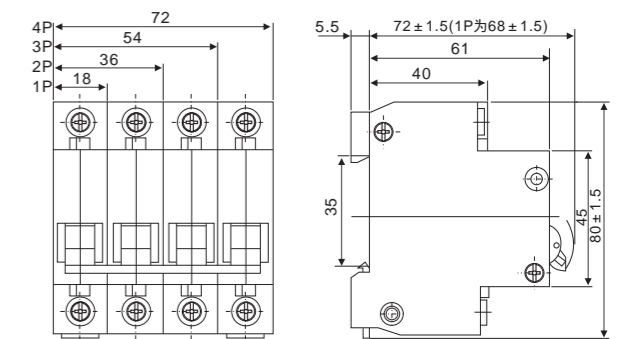

TH35-7.5型安装导轨尺寸
TH35-7.5 DIN rails size

订货须知 Ordering information

订货时要标明下列各点:

- 产品型号和名称, 如DZ47-63小型断路器;
- 瞬时脱扣型式和额定电流, 如C25;
- 断路器极数, 如2P;
- 订货数量, 如60台;
- 订货举例: DZ47-63小型断路器, 2P, C25, 60台。

备注: DZ47-63与DZ47-63H所有技术参数一致。

When ordering the goods, the user shall indicate the following items:

- Types and names of products, for example, DZ47-63 miniature circuit breaker;
- Instantaneous tripping type and rated current, for example, C25;
- Number of poles: for example, 2P;
- Amount on order, for example, 60 units;
- Example for ordering: 60 units of the DZ47-63 series miniature circuit breakers, 2P, C25.

DZ47-125 系列小型断路器 Series Miniature Circuit Breaker



主要参数及技术性能 Main technical data

表1 Table1

技术参数项目 Item	参数值 Parameter
额定电压(V) Rated voltage	230V~(1P)、400V~(2P, 3P, 4P)
额定电流(A) Rated Current	63、80、100、125
极数 Poles	1P, 2P, 3P, 4P
额定短路分断能力Icu(A) Rated short-circuit breaking capacity	6000
过电流保护特性 Overcurrent protection characteristic	见表2、图1 See Table 2, Figure 1
温度补偿系数 Temperature compensation coefficient	见表3 See Table 3
不同海拔修正系数 Different Altitude correction factor	见表4 See Table 4
机械电气寿命(次) Mechanical and electrical life (times)	见表5 See Table 5
连接导线(mm ²) Wire	见表6 See Table 6
拧紧力矩(N.m) Tightening torque	3.5
外形尺寸 Dimensions	图2、图3 See Figure 2, 3
污染等级 Pollution Level	3级
防护等级 Protection class	IP20
安装类别 Installation category	类

过电流保护特性(基准温度30℃) Over current protection characteristics (30℃)

表2 Table2

序号 No.	脱扣器额定电流(A) Rated current	起始状态 Initial state	试验电流 Test current	约定时间 Time limit	预期结果 Expected result	起始状态 Remarks
1	$I_n=63$	冷态 Cold state	$1.05I_n$	t 1h	不脱扣 No tripping	—
	$I_n > 63$	冷态 Cold state	$1.05I_n$	t 2h	不脱扣 No tripping	—
2	$I_n=63$	紧接前项试验后进行 Right after test number 1	$1.30I_n$	t < 1h	脱扣 Tripping	电流在5s内稳定 地上升至规定值 The current is rising within 5s
	$I_n > 63$		$1.30I_n$	t < 2h	脱扣 Tripping	
3	$I_n=63$	冷态 Cold state	$8I_n$	t 0.2s	不脱扣 No tripping	—
			$12I_n$	t < 0.2s	脱扣 Tripping	—

注：“冷态”指在基准校准温度下，试验前不带负载。

Note: the terminology "Cold state" means that the test is performed at the base calibration temperature with no load prior to the test.

适用范围 Application

DZ47-125小型断路器主要用于交流50Hz, 单极230V, 二、三、四极400V; 额定电流63A至125A线路中作为用电线路的过载、短路保护之用, 同时也可以在正常情况下不频繁通断电器装置和用电线路, 也可作为断开线路进行线路及设备维修的隔离开关使用。

符合标准: GB 14048.2、IEC 60947-2, 获得CCC、CE认证。

The DZ47-125 series miniature circuit breaker is applicable to the circuit an alternating current of 50Hz, rated voltage of 230/400V, and rated current 63-125A for overload protection and short circuit protection and also for not-frequent operational transformation in the circuit under normal condition. This product can be applied to various places such as industrial, commercial, and tall buildings, and residential houses.

The product meets the standards of GB14048.2, IEC60947-2, Obtained CCC, CE certification.

型号及其含义 Code and implication

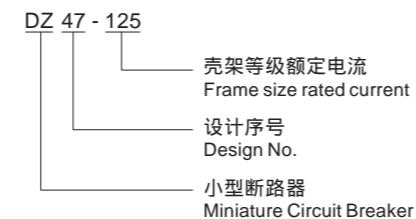

正常工作条件 Normal operating conditions

正常操作条件

- 环境温度: -5 ~ +40℃; 24h内平均值不超过35℃。
- 海拔高度: 安装地点的海拔不超过2000m。
- Ambient air temperature: -5℃~+40℃, the mean value is no greater than +35℃ within 24 hours.
- Altitude: not higher than 2000m for the installation site.

不同环境温度下使用的电流修正值 Current correction value for use at different ambient temperatures

表3 Table3

修正电流值(A) Corrected current value 额定电流(A) Rated current	温度(℃) Temperature	-35	-30	-20	-10	0	10	20	30	40	50	60	70
63		90.40	88.52	84.75	80.33	76.55	72.45	67.73	63	57.65	51.98	46.31	40.95
80		114.8	112	106.8	101.6	96.4	90.8	85.6	80	74	67.6	60.4	53.2
100		143.5	140.5	134.5	127.5	121	113.5	107.5	100	92.5	84.5	75.5	66.5
125		178.75	173.75	164.38	156.25	148.75	140.63	135	125	116.25	107.5	97.5	85

脱扣特性曲线图(见图1)。Characteristic curve(See Fig.1)



图1 Fig.1

不同海拔下使用的电流修正系数

Current correction coefficient used in different altitude

表4 Table4

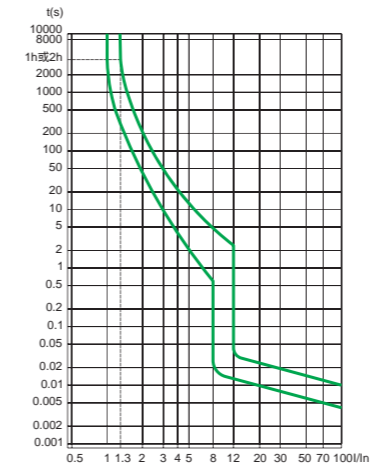
额定电流(A) Rated current	不同海拔修正系数		
	2000m	(2000~3000)m	3000m
63、80、100、125	1.0	0.9	0.8

机械电气寿命 Mechanical and electrical life

表5 Table5

额定电流(A) Rated current	操作循环次数 Operating cycles	
	有载 Load	无载 No-load
63、80、100	1500	20000
125	1000	20000

接线: 适用50mm以下导线连接 (见表6), 接线端子扭矩不大于3.5N·m

Wiring: good for connection of leads of less than 50mm² (see table6);

Wiring method: screw hold-down with a torque of 3.5 N.m

表6 Table 6

额定电流In(A) Rated current	铜导线标称截面积(mm ²) Nominal cross-sectional area of the copper conductor
63	16
80	25
100	35
125	50

其它

结构特点

- 额定短路分断能力高, 全部额定电流等级均可达到6kA。
- 具有红绿安全指示, 安全性更高。
- 带储能式机构操作, 触点快速闭合, 克服了因人力操作手柄速度快慢带来的不利影响, 大大提高了产品的使用寿命。
- 产品可配合多种模块化附件使用, 如AX-1。

Others

Structural features

- High rated short circuit breaking capacity, the breaker of all rated currents can reach up to 6KA
- Red/green safety indication provided, to get higher safe level
- Energy charged mechanism provided, to ensure the contacts can be closed quickly, overcome the problem of too slow/quick operating speed through manual operation.
- Many module accessories can be operated, such as AX-1

外形及安装尺寸 Outline & installation size

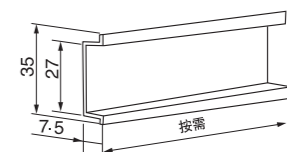
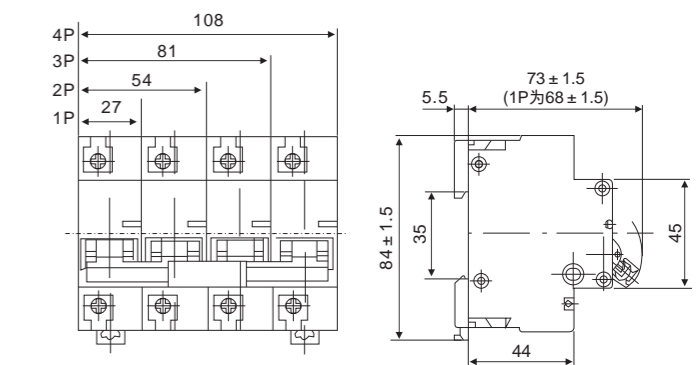

TH35-7.5型安装导轨尺寸
TH35-7.5 DIN rails size

订货须知 Ordering information

订货时要标明下列各点:

- 产品型号和名称, 如DZ47-125小型断路器;
- 额定电流, 如63A;
- 断路器极数, 如2P;
- 订货数量, 如60台;
- 订货举例: DZ47-125小型断路器, 2P, 63A, 60台。

When ordering the goods, the user shall indicate the following items:

- Types and names of products, for example, DZ47-125 miniature circuit breaker;
- Rated current, for example, 63A;
- Number of poles: for example, 2P;
- Amount on order, for example, 60 units;
- Example for ordering: 60 units of the DZ47-125 series miniature circuit breakers, 2P, 63A.

ZML7 系列小型断路器 Series Miniature Circuit Breaker



主要参数及技术性能 Main technical data

表1 Table1

技术参数项目 Item	参数值 Parameter
额定电压(V) Rated voltage	230V AC(1P), 400V AC(2P, 3P, 4P)
额定电流(A) Rated Current	1A, 2A, 3A, 4A, 6A, 10A, 16A, 20A, 25A, 32A, 40A, 50A, 63A
极数 Poles	1P, 2P, 3P, 4P
瞬时脱扣类型 Instantaneous tripping type	B型(3~5)In, C型(5~10)In, D型(10~16)In
额定短路分断能力Icu(A) Rated short-circuit breaking capacity	见表2 See Table 2
机械电气寿命(次) Mechanical and electrical life (times)	见表3 See Table 3
脱扣特性 Tripping characteristic	见表4及图1、图2、图3 See Table 4, Fig1,2,3
连接导线(mm ²) Wire	见表5 See Table 5
拧紧力矩(N.m) Tightening torque	2.0
外形尺寸及安装尺寸 Dimensions	见图4、图5
污染等级 Pollution Level	2级
防护等级 Protection class	IP20
安装类别 Installation category	、 类

额定短路分断能力 Rated short-circuit breaking capacity

表2 Table2

额定电流In(A) Rated current	极数 Poles	额定电压Ue(V) Rated voltage	额定短路能力Icn(A) Rated short-circuit capacity
B、C型：1-40	1	230/400	6000
	2, 3, 4	400	
B、C型：50, 63	1	230/400	4500
	2, 3, 4	400	
D型：1-63	1	230/400	4500
	2, 3, 4	400	

机械电气寿命 Mechanical and electrical life

表3 Table3

类型 Type	寿命次数 Life times
电气寿命 Electrical life	4000次 Times
机械寿命 Mechanical life	10000次 Times

适用范围 Application

ZML7小型断路器适用于交流50Hz, 额定电压230/400V, 额定电流至63A的线路中作过载和短路保护之用, 也可以在正常情况下作为线路的不频繁操作转换之用, 也可作为断开线路进行线路及设备维修的隔离开关使用。断路器适用于工业、商业、高层和民用住宅等各种场所。符合标准: GB 10963.1、IEC 60898-1, 获得CCC认证。

The ZML7 series miniature circuit breaker is applicable to the circuit an alternating current of 50Hz, rated voltage of 230/400V, and rated current up to 63A for overload protection and short circuit protection and also for not-frequent operational transformation in the circuit under normal condition. This product can be applied to various places such as industrial, commercial, and tall buildings, and residential houses. The product meets the standards of GB10963.1, IEC60898-1, Obtained CCC certification.

型号及其含义 Code and implication

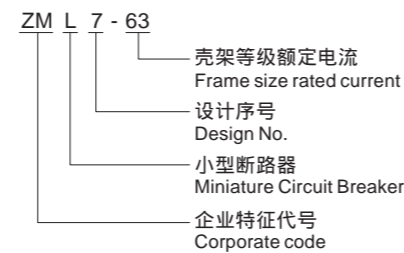

正常工作条件 Normal operating conditions

正常操作条件

- 环境温度 -5 ~ +40 ; 24h内平均值不超过35。
- 海拔高度: 安装地点的海拔不超过2000m。
- Ambient air temperature: -5°C~+40°C, the mean value is no greater than +35°C within 24 hours.
- Altitude: not higher than 2000m for the installation site.

过电流保护特性(基准温度30) Over current protection characteristics (30°C)

表4 Table4

试验 Test	型式 Type	试验电流 Test current	起始状态 Initial state	脱扣或不脱扣时间极限 Time limit for tripping or No tripping	预期结果 Expected result	试验环境温度 Test temperature	备注 Remarks
a	B、C、D	1.13In	冷态 Cold state	t > 1h	不脱扣 No tripping	30 ~35	电流在5s内稳定地上升 The current is rising within 5s
b	B、C、D	1.45In	紧接着a项试验	t < 1h	脱扣 Tripping		
c	B、C、D	2.55In	冷态 Cold state	1s < t < 60s (In ≤ 32A) 1s < t < 120s (In > 32A)	脱扣 Tripping		
d	B	3In	冷态 Cold state	t > 0.1s	不脱扣 No tripping		通过闭合辅助开关接通电源 The power supply is turned on by closing the auxiliary switch
d	C	5In					
d	D	10In					
e	B	5In	冷态 Cold state	t < 0.1s	脱扣 Tripping	通过闭合辅助开关接通电源 The power supply is turned on by closing the auxiliary switch	
e	C	10In					
e	D	16In					

脱扣特性曲线图 Characteristic curve



图1 B型 Fig.1 B type

图2 C型 Fig.2 C type

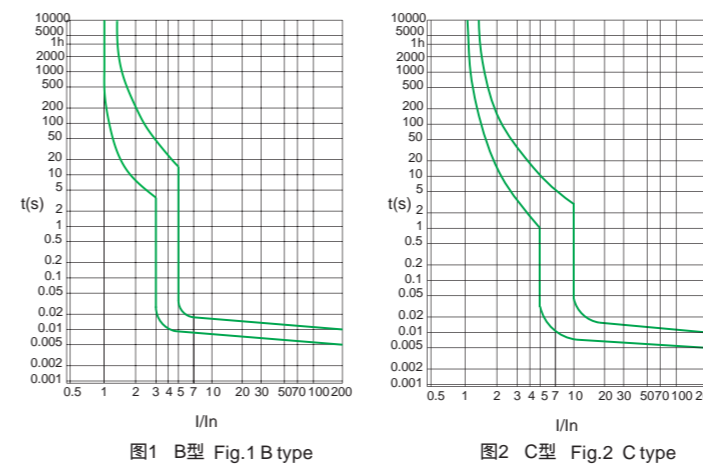

图3 D型 Fig.3 D type

- 接线: 适用25mm以下导线连接 (见表5), 扭矩2.0N·m
Wiring: good for connection of leads of less than 25mm² (see table5);
Wiring method: screw hold-down with a torque of 2 N.m

表5 Table 5

额定电流In(A) Rated current	铜导线标称截面积(mm ²) Nominal cross-sectional area of the copper conductor
1-6	1
10	1.5
16, 20	2.5
25	4
32	6
40, 50	10
63	16

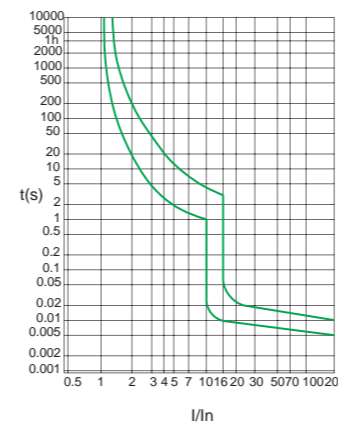
结构特征 Structural features

- 套管创新设计, 防止产品接线开裂, 更安全
Sleeve ring design, to prevent the crack of wire connection, much safer
- 安装尺寸范围大, 便于汇流排安装
Large mounting size, for busbar channel
- 人性化手柄
Humanized handle
- 指示窗口
Indication window
- 剥线长度、扭矩指示
Indication of cable peeling length, torque

外形及安装尺寸 Outline & installation size

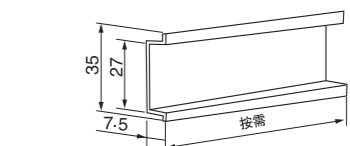
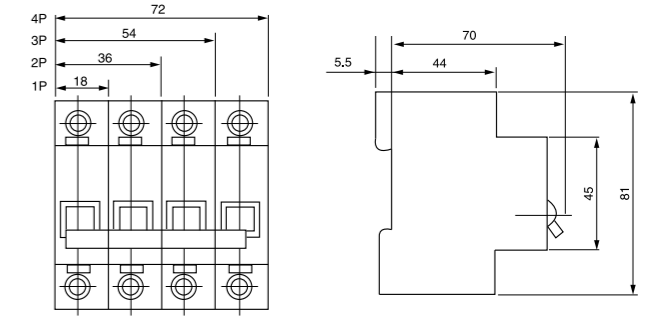

TH35-7.5型安装导轨尺寸 TH35-7.5 DIN rails size

订货须知 Ordering information

订货时要标明下列各点:

- 产品型号和名称, 如ZML7小型断路器;
- 瞬时脱扣型式和额定电流, 如C25;
- 断路器极数, 如2P;
- 订货数量, 如50台;
- 订货举例: ZML7小型断路器, 2P, C25, 50台。

When ordering the goods, the user shall indicate the following items:

- Types and names of products, for example, ZML7 miniature circuit breaker;
- Instantaneous tripping type and rated current, for example, C25;
- Number of poles: for example, 2P;
- Amount on order, for example, 50 units;
- Example for ordering: 50 units of the ZML7 series miniature circuit breakers, 2P, C25.

DZ47-63DC

系列交直流用小型断路器

Series AC/DC Miniature Circuit Breaker



主要参数及技术性能 Main technical data

主要规格 Main Specifications:

- 按额定电流In分 Rated current : 1A、2A、3A、4A、6A、10A、16A、20A、25A、32A、40A、50A、63A ;
- 按瞬时脱扣器的型式 (见表1) Instantaneous release (See Table1)

表1 Table1

脱扣型式 Trip Type	交流范围 AC range	直流范围 DC range
B	3In < I 5In	4In < I 7In
C	5In < I 10In	7In < I 15In

- 按极数分：a.单极断路器；b.带二个保护极的断路器。
Poles: a. single Poles Circuit Breaker; b. With a two-pole circuit breaker protection

技术参数 Main technical data

- 额定短路能力(见表2、表3) Rated short-circuit capacity (see Table 2 and Table 3)

直流参数 DC parameters

表2 Table2

额定电流(A) Rated current	极数 Poles	额定电压(V) Rated voltage	额定短路电流(A) Rated short-circuit current	运行短路电流(A) Short-circuit current
1-63	1	220	6000	7500
	2	220	10000	6000

交流参数 AC parameters

表3 Table3

额定电流(A) Rated current	极数 Poles	额定电压(V) Rated voltage	额定短路电流(A) Rated short-circuit current	运行短路电流(A) Short-circuit current
1-63	1	230/400	10000	7500
	2	400		

- 机械电气寿命(见表4) Mechanical and electrical life (see Table 4)

表4 Table4

类别 Category	次数 Times	操作频率(次/时) Operating frequency (times / hour)	额定电流(A) Rated current
电气寿命 Electrical life	AC4000/DC1000	240	1-32
		120	40-63
机械寿命 Mechanical life	20000	240	1-63

适用范围 Application

DZ47-63DC系列直流用小型断路器适用于交流50/60Hz额定电压230/400V, 额定电流至63A线路中, 或流电压220V, 额定直流电流至63A线路中作过载和短路保护之用, 也可以在正常情况下作为线路的不频繁操作转换之用。断路器适用于工业、商业、高层和民用住宅等各种场所。符合标准: GB 10963.2、IEC 60898-2, 获得CCC认证。

DZ47-63DC series DC mini circuit breaker is operating in the line of AC 50/60HZ rated voltage 230/400V, rated current up to 63A, or DC 220V, rated DC current up to 63A, to protect from overloading and short circuit, also used to shift the line non-frequently. The breaker is suitable for operating in industry, commercial, high building and civil house, complies with GB 10963.2、IEC 60898-2 standards, the product awards CCC certification.

型号及其含义 Code and implication

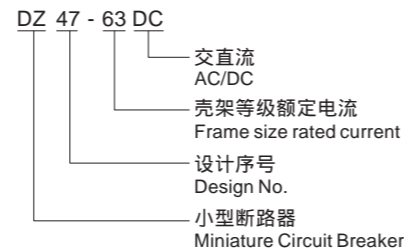

正常工作条件

Normal operating conditions

- 环境温度 -5 ~ +40 ; 24h内平均值不超过35。
- 海拔高度: 安装地点的海拔不超过2000m。
- Ambient air temperature: -5°C~+40°C, the mean value is no greater than +35°C within 24 hours .
- Altitude: not higher than 2000m for the installation site.

过电流保护特性 (直流) Over current protection characteristics (DC)

表5 Table5

序号 No.	脱扣器额定电流(A) Test current	起始状态 Initial state	直流 DC current	规定时间 Time limit	预期结果 Expected result	备注 Remarks
1	1-63	冷态 Cold state	1.13In	t 1h	不脱扣 No tripping	
2	1-63	紧接着前项试验后进行	1.45In	t < 1h	脱扣 Tripping	电流在5s内稳定地上升至规定值
3	In 32	冷态 Cold state	2.55In	1s < t < 60s	脱扣 Tripping	
	In > 32	冷态 Cold state	2.55In	1s < t < 120s	脱扣 Tripping	
4	1-63	冷态 Cold state	4In	0.1s t 45s(In 32A) 0.1s t 90s(In > 32A)	脱扣 Tripping	B型 B Type
			7In	0.1s t 15s(In 32A) 0.1s t 30s(In > 32A)	脱扣 Tripping	C型 C Type
			7In 15In	t < 0.1s	脱扣 Tripping	B型 B Type C型 C Type

脱扣特性曲线图 Characteristic curve

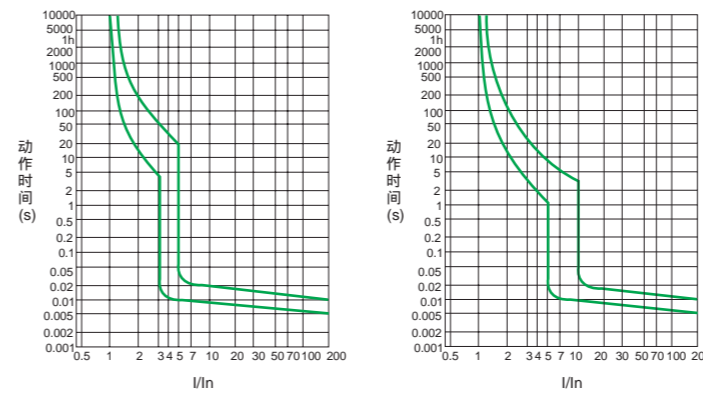
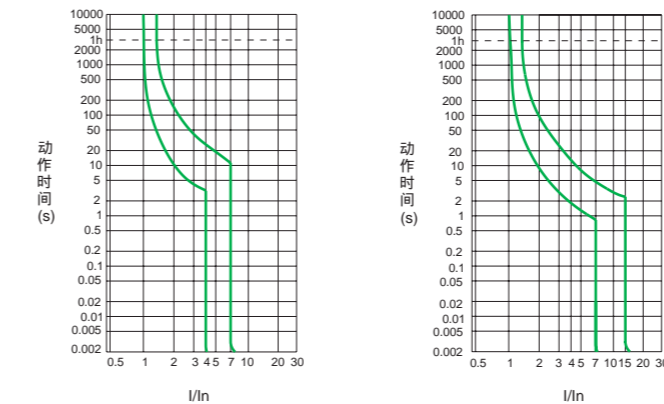

- 接线: 适用25mm以下导线连接 (见表7), 扭矩2.0N·m
Wiring: good for connection of leads of less than 25mm² (see table7);
Wiring method: screw hold-down with a torque of 2 N.m

表7 Table 7

额定电流In(A) Rated current	铜导线标称截面积(mm ²) Nominal cross-sectional area of the copper conductor
1-6	1
10	1.5
16、20	2.5
25	4
32	6
40、50	10
63	16

过电流保护特性 (交流) Over current protection characteristics (AC)

表6 Table6

序号 No.	脱扣器额定电流(A) Test current	起始状态 Initial state	直流 DC current	规定时间 Time limit	预期结果 Expected result	备注 Remarks
1	1-63	冷态 Cold state	1.13In	t 1h	不脱扣 No tripping	
2	1-63	紧接着前项试验后进行	1.45In	t < 1h	脱扣 Tripping	电流在5s内稳定地上升至规定值
3	In 32	冷态 Cold state	2.55In	1s < t < 60s	脱扣 Tripping	
	In > 32	冷态 Cold state	2.55In	1s < t < 120s	脱扣 Tripping	
4	1-63	冷态 Cold state	3In	t 0.1s	不脱扣 No tripping	B型 B Type
			5In	t < 0.1s	脱扣 Tripping	
			5In	t 0.1s	不脱扣 No tripping	
			10In	t < 0.1s	脱扣 Tripping	C型 C Type

结构特征 Structural features

- 额定短路断能能力高。
- 双重接线功能, 出线端可方便地连接标准汇流排和软硬导线, 进线端可连接软硬导线。
- 带指触防护组合型接线端子及红绿安全指示, 安全性更高。
- 带储能式机构操作, 触点快速闭合, 克服了因人力操作手柄速度缓慢带来的不利影响, 大大提高了产品的使用寿命。
- 产品可配合多种模块化附件使用, 如S9,V9,XF9,XF9J。
- 壳体和部分功能件均采用高阻燃、耐高温、耐冲击塑料制成。

外形及安装尺寸 Outline & installation size

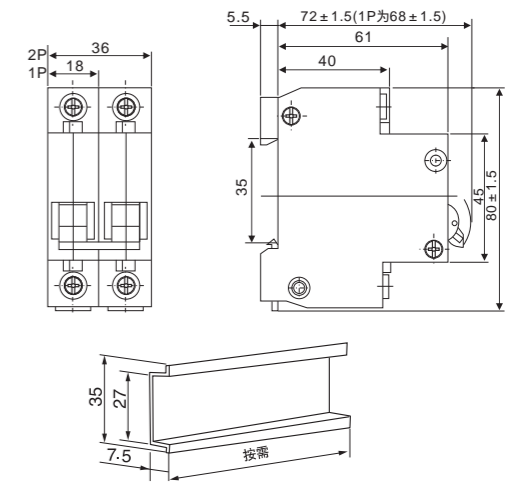

TH35-7.5型安装导轨尺寸 TH35-7.5 DIN rails size

订货须知 Ordering information

订货时要标明下列各点:

- 产品型号和名称, 如DZ47-63DC交直流用小型断路器;
- 瞬时脱扣型式和额定电流, 如C20;
- 断路器极数, 如2P;
- 订货数量, 如500台;
- 订货举例: DZ47-63DC交直流用小型断路器, 2P, C20, 500台。

When ordering the goods, the user shall indicate the following items:

- Types and names of products, for example, DZ47-63DC miniature circuit breaker;
- Instantaneous tripping type and rated current, for example, C20;
- Number of poles: for example, 2P;
- Amount on order, for example, 500 units;
- Example for ordering: 500 units of the DZ47-63DC miniature circuit breakers, 2P, C20.

DZ30-32

小型断路器

Miniature Circuit Breaker



主要参数及技术性能 Main technical data

分类：

- 按额定电流分：6A、10A、16A、20A、25A、32A；
- 按极数为带一个保护极的二极断路器(1P+N)；
- 瞬时脱扣器的型式为C型(5In~10In)。

主要技术参数及指标：

- 时间-电流动作特性(见表1)；
- 运行短路能力：4500A；
- 机械电气寿命：4000次；

Specification

- Rated current：6A, 10A, 16A, 20A, 25A, 32A;
- Poles: protected poles with a two-pole circuit breakers (1P + N);
- Instantaneous release: type C (5In ~ 10In).

Main technical parameters:

- Time - current operating characteristics (See Table 1);
- Circuit capacity: 4500A;
- Mechanical and electrical life: 4000;

表1 Table1

序号 No.	脱扣器额定电流In Rated current	起始状态 Initial state	试验电流 Test current	规定时间 Time limit	预期结果 Expected result	试验环境温度 Test temperature	备注 Remarks
a	32A	冷态Cold state	1.13In	t 1h	不脱扣No tripping	30 ~35	电流在5s内稳定 地上升至规定值 The current is rising within 5s
b		紧接着a项试验后进行 Right after test No. a	1.45In	t<1h	脱扣Tripping		
c		冷态Cold state	2.55In	1s<t<60s	脱扣Tripping		
d		冷态Cold state	5In	t 1h	不脱扣No tripping		
e		冷态Cold state	10In	t<0.1s	脱扣Tripping		

- 接线：断路器使用时参照表2选取铜导线截面积；
Wiring: good for connection of leads see table 2

表2 Table2

额定电流In(A) Rated current	In 6	6<In 13	13<In 20	20<In 25	25<In 32
铜导线截面积 S(mm ²) Nominal cross-sectional area of the copper conductor	1	1.5	2.5	4	6

适用范围 Application

DZ30-32型断路器(以下简称断路器)主要用于交流50Hz或60Hz,额定电压230,额定电流至32A的线路中作过载、短路保护,同时也可以在正常情况下作为线路的不频繁转换之用,尤其适用于住宅的照明配电系统。符合标准:GB 10963.1、IEC 60898-1。

The DZ30-32 series miniature circuit breaker is applicable to the circuit an alternating current of 50Hz, rated voltage of 230V, and rated current up to 63A for overload protection and short circuit protection and also for not-frequent operational transformation in the circuit under normal condition. This product can be applied to various places such as industrial, commercial, and tall buildings, and residential houses. The product meets the standards of GB10963.1, IEC60898-1.

型号及其含义 Code and implication

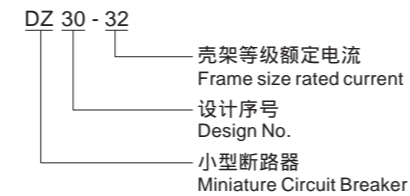

正常工作条件

Normal operating conditions

- 环境温度-5 ~+40 ;24h内平均值不超过35。
- 海拔高度：安装地点的海拔不超过2000m。
- Ambient air temperature: -5°C~+40°C, the mean value is no greater than +35°C within 24 hours .
- Altitude: not higher than 2000m for the installation site.

- 脱扣特性曲线图(见图1)。Characteristic curve(See Fig.1)



图1 Fig.1

结构特点 Structural features

- 产品体积小,结构紧凑,18mm宽度内拥有1P+N两极,是DZ47两极产品体积的一半。价格优于同类产品。
- 产品壳体及部分功能件均采用高阻燃、耐高温、耐冲击塑料制成。
- 产品直接带零线安装,避免零线接线错误潜在的触电危险。
- 产品采用导轨安装,方便省时。
- Small size, compact structure, two poles 1P+N width 18mm, is half width of 2-P DZ47. the price is cheaper than other same product
- the shell and some functional parts made of high flameproof, hi-temperature withstand, impact withstand plastic material.
- The product directly connected with neutral line, to avoid wrong connection and leading to electric shock.
- rail mounting, easy installation and save time.

外形及安装尺寸 Outline & installation size

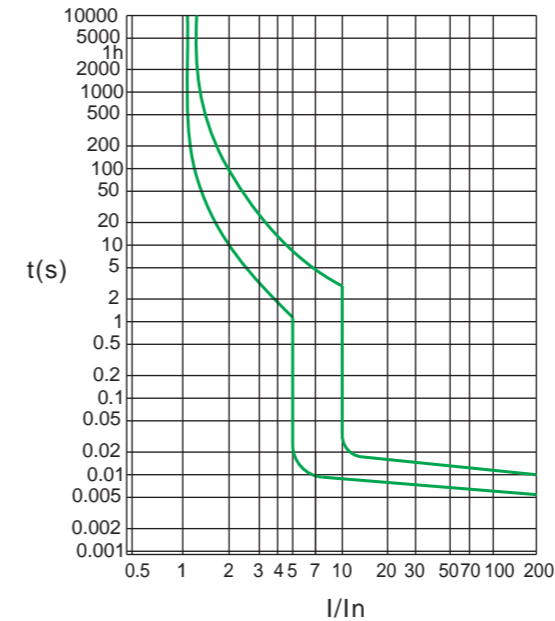
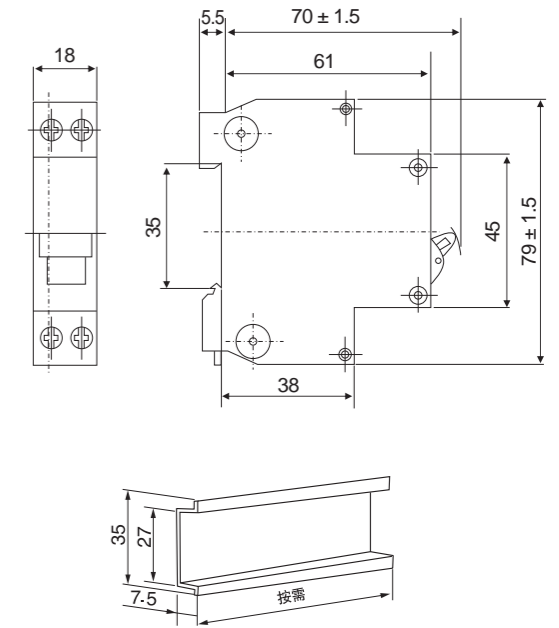

TH35-7.5型安装导轨尺寸
TH35-7.5 DIN rails size

订货须知 Ordering information

订货时要标明下列各点：

- 产品型号和名称,如DZ30-32小型断路器；
- 瞬时脱扣型式和额定电流,如C20(照明保护型额定电流20A)；
- 订货数量,如240台；
- 订货举例：DZ30-32小型断路器,C20,240台。

When ordering the goods, the user shall indicate the following items:

- Types and names of products, for example, DZ30-32 miniature circuit breaker;
- Instantaneous tripping type and rated current, for example, C20;
- Amount on order, for example, 240 units;
- Example for ordering: 240 units of the DZ30-32 series miniature circuit breakers, C20.

ZMB-1S-63

带分励脱扣器小型断路器 (卡式电表专用开关)

Miniature circuit breaker with shunt release (special switch for card type meter)



型号及其含义 Code and implication

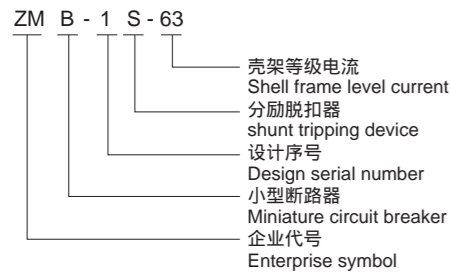

注：ZMB1S-63为控制信号断电延时脱扣。
主要规格：断路器按额定电流In分：10A、20A、25A、32A、40A、50A、63A。
Note: ZMB1S-63 is of control signal power failure time delay tripping.
Main specifications: circuit breakers can be divided according to the rated current In: 10A, 20A, 25A, 32A, 40A, 50A, 63A.

技术参数

- 断路器瞬时脱扣器的供货形式为C型，其他型式用户可很特殊订货；
- 断路器的短路分断能力10A、20A、25A、32A、40A、50A、63A为Im6000A；
- 断路器过电流保护特殊(见表1)

Technical parameters

- Supplying goods of instantaneous release of circuit breaker is C type, other types are available by making special orders;
- Short-circuit breaking capacity of circuit breaker of 10A, 20A, 25A, 32A and 40A, 50A, 63A is Im 6000A;
- Over-current protection characteristic of circuit breaker (see table 1)

表Table1

额定电流 A Rated Current	起始状态 Initial state	试验电流 A Test current	试验时间 Test time	预期结果 Appointed result
全部规格 All type	冷态 Cold state	1.13In	t 1h	不脱扣 No trip
全部规格 All type	紧接着前项试验后进行	1.45In	t < 1h	脱扣 Trip
In 32	冷态 Cold state	2.55In	1s < t < 60s	脱扣 Trip
In > 32			1s < t < 120s	
全部规格 All type	冷态 Cold state	5In	t 0.1s	不脱扣 No trip
			10In	t < 0.1s

分励脱扣特性(见表2) Shunt tripping characteristic (see table 2)

表Table2

型号	动作电压	动作时间	重复操作间隔时间
ZMB1S-63	230V	0.5s < t < 2s	3min

机械电气寿命

电气寿命：4000次，COS =0.85~0.9；
机械寿命：6000次。(其中5000次直接人力操作，操作频率In=25A为240次/小时，In > 25A为120次/小时；1000次由分励脱扣器控制分断，每次间隔时间 3min)

Mechanical and electric life

Electric life: 4000 times, COS =0.85~0.9;
Mechanical life: 6000 times. (Thereinto, 5000 times of direct manual operation, operating frequency In=25A is 240times/h), In > 25A is 120times/h;
The rest 1000 times of breaking is controlled by shunt release, every interval time 3min)

适用范围 Application

ZMB-1S-63带分励脱扣器(卡式电表专用开关)，具有分励脱扣功能，适用于交流50Hz或60Hz，额定工作电压为230/400V，额定电流至63A的线路中，对线路进行远跨度控制分断或自动信号控制分断，同时对线路起过载和短路保护的作用，也可以作为线路的不频繁操作转换之用。目前广泛应用于与IC卡预付费电表配套使用来控制线路的通断，是IC卡预付费电表配套使用的最理想产品。

本产品符合GB10963.1-2005标准，具有国际先进水平。

ZMB-1S-63 miniature circuit breaker with shunt release (special switch for card type meter) has function of shunt tripping, is suitable for circuitries of AC50Hz or 60Hz, rated working voltage is 230/400V and rated current up to 63A, it carries out far-span control breaking or automatic signal control breaking to the circuitries, while protects the circuitries against overload or short-circuit, it also can be used for infrequent changeover for circuitries. At present, the products are widely matched with IC card prepayment wathour meters and used to control the making and breaking of circuitries, are ideal supporting products for IC card prepayment wathour meters. The products are in conformity with GB10963.1-2005, with international advanced level.

外形及安装尺寸 Outline & installation size

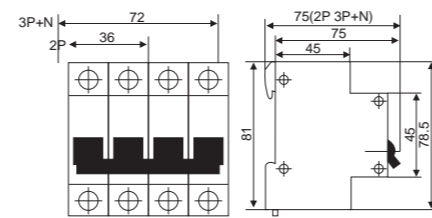

ZMB1S-63

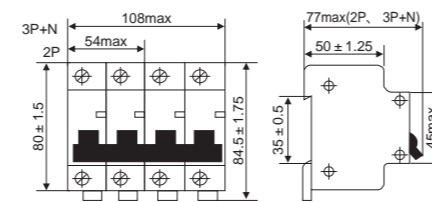

ZMB1S-100

功能特点

- 断路器具有一个过电流保护极和一个开闭中性极，并带有分励脱扣装置。
- 开闭中性极比过电流保护极先接通后分断；
- 额定分断能力高，可达6kA；
- 断路器操作机构为带储能式自由脱扣机构，触点快速闭合，克服了因人力操作手柄速度快慢带来的不利影响，大大提高了产品使用寿命；在正常工作时，触头只能停留在闭合或断开位置；
- 带指触防护组合型接触端子，安全性能高；
- 分励脱扣器由可控硅、电磁脱扣器等组成驱动元件；
- 壳体和部件均采用国外进口的高阻燃、耐高温、耐冲击塑料制成。

工作原理

使用时通过信号输入端口给断路器智能分励脱扣器极加上控制电压，即信号电压(可由远端控制线路提供)，然后将断路器手柄推向闭合位置，通过操作机构带动触头向静触头运行并与静触头可靠接触，并接通线路。当线路发生过载故障时，过载电流使热双金属元件弯曲，过载脱扣器动作，推动锁定机构复位，从而实现分断线路。当线路发生短路故障时，短路电流使瞬时脱扣器动作，推动锁定机构复位，实现分断线路。当因为某种需要，必须立即切断线路时，可能通过无线控制系统断开控制电压，此时信号电压检测电路得到信号后，对分励线圈输出电压信号，推动整个分励线圈动作，并同时带动锁定机构复位，实现分断功能。因此，该产品不同的线路状态下，均能达到分断的目的。

应用示例

- 具体常见的应用方案(见图1)
- 根据用户需要本公司可生产额定最大电流100A的卡式电表专用开关。
- Frequently used application schemes (see Fig.1)
- The company also is able to product the rated max current at request Special switch of 100A for card type meter

安装接线图(见图2) The wires-referring (see chart 2)



图2
Figure 2

Function characteristic

- The circuit breaker has an over-current protection pole and an opening and closing neutral pole, as well as shunt tripping device.
- Opening and closing neutral pole will make first and break later than the over-current protection pole;
- High rated breaking capacity, as high as 6kA;
- Operating mechanism of the circuit breaker is a free trip mechanism with energy storage function, the contact can close quickly, it overcomes the adverse effect caused by the handle speed variation of manual operation, improves the product's service life greatly; during normal working, the contact can only rest on closing or breaking position;
- Combined type contact terminal with finger touch protection, high safety;
- Drive element of shunt release is composed of thyristor, electromagnetic release and so on;
- Both the shell and components are made of imported high flame retardant, high temperature resistant and impact resistant plastics.

Working principle

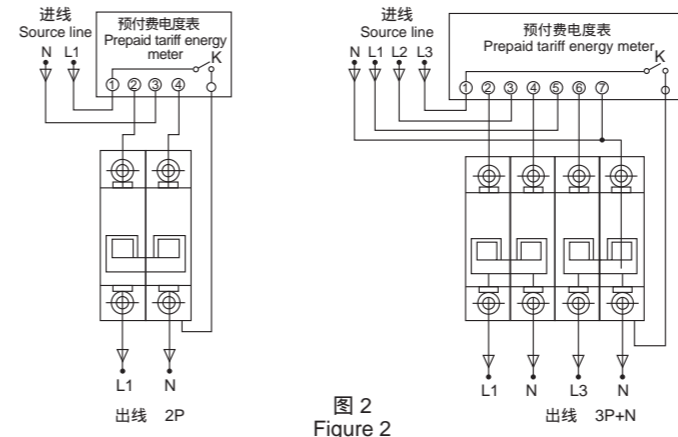
When using, apply control voltage to the intelligent shunt release pole of circuit breaker through signal input port, i.e. signal voltage (can be provided by remote control circuit), then push the circuit breaker handle towards closing position, drive the moving contact to run towards static contact and reliably contacting with it through operating mechanism, and put through the circuit. When the circuit has overload fault, overload current would bend the bimetallic element, overload release acts and pushes the locking mechanism to reset, to break the circuit. When the circuit has short-circuit fault, short-circuit current would make the instantaneous release act, which pushes the locking mechanism to reset, to break the circuit. When the circuit must be cut off immediately for some reason, the control voltage may be cut off by wireless control system, at this moment, the signal voltage detection circuit receives the signal, and outputs voltage signal to the shunt coil, it drives the whole shunt coil to act, and pushes the locking mechanism to reset, to realize breaking function. Therefore, this product is able to realize breaking under different circuit states.

Application example



图1
Figure 1

DZ47LE-63

系列剩余电流动作断路器

Series Residual Current Operated Circuit Breaker

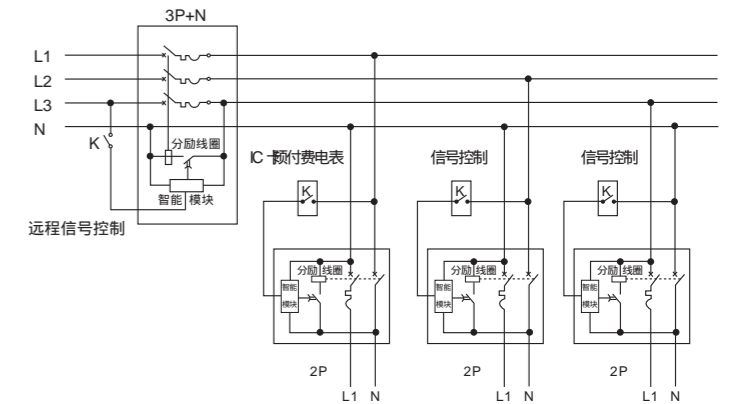

型号及其含义 Code and implication

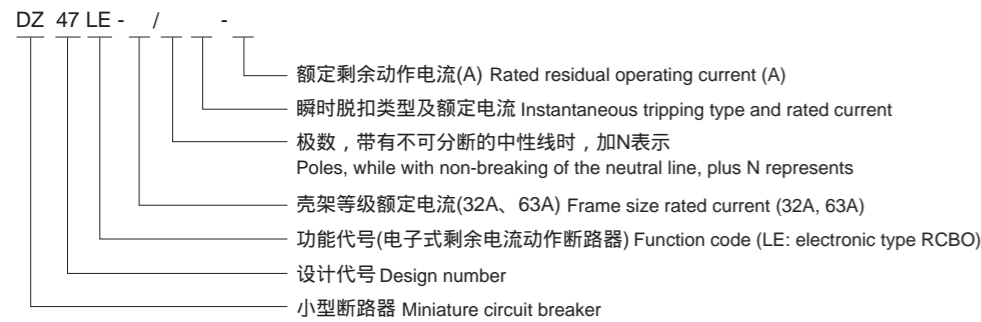

主要参数及技术性能 Main technical data

主要规格:

- 额定电流(In): 壳架等级电流32A为:6A,10A,16A,20A,25A,32A; 壳架等级电流63A为:6A,10A,16A,20A,25A,32A,40A,50A,63A;
- 额定剩余动作电流I_n:0.03A,0.05A,0.1A,0.3A;
- 按极数和电流回路分为:
 - 单极二线剩余电流动作断路器(1P+N);
 - 两极剩余电流动作断路器(2P);
 - 三极剩余电流动作断路器(3P);
 - 三极四线剩余电流动作断路器(3P+N);
 - 四极剩余电流动作断路器(4P);
- 按瞬时脱扣器特性分:C型(5-10)In,D型(10-16)In。

主要技术参数:

- 额定电压Un(V):单极二线,两极220V;三极,三极四线,四极为380V;
- 额定短路能力Icn(A) 壳架等级电流32A为:4000 壳架等级电流63A为:3000
- 额定剩余接通和分断能力I_m(A):2000;
- 额定剩余不动作电流I_{no}:0.5I_n;

Main specifications

- Graded as follows according to the rated current In: DZ47LE-32: 6A, 10A, 16A, 20A, 25A, 32A; DZ47LE-63: 6A, 10A, 16A, 20A, 25A, 32A, 40A, 50A, 63A
- Graded as follows according to the rated residual operating current: 0.03A, 0.05A, 0.1A, 0.3A;
- Categorized as follows according to the number of poles and current circuit:
 - Single pole and two lines (1P+N)
 - Two poles (2P)
 - Three poles(3P)
 - Three poles and four lines (3P+N)
 - Four poles (4P)
- Classified as follows according to the type of instantaneous release: C type (5-10) In, D type (10-16) In;

Technical parameters

- Rated voltage Un (V): Single pole and two lines 220V; Three poles, Three poles and four lines 380V;
- Rated short-circuit capacity Icn (A) DZ47LE-32: 4000 DZ47LE-63: 3000
- Rated residual making and breaking capacity I_m (A): 2000;
- Rated residual non-operating current I_{no}: 0.5I_n;

适用范围 Application

DZ47LE系列剩余电流动作断路器适用于交流50Hz或60Hz, 额定电压单极二线、两极220V, 三极、三极四线、四极380V, 额定电流至63A的线路中, 当人身触电或电网泄漏电流超过规定值时, 剩余电流动作断路器能在极短的时间内迅速切断故障电源, 保护人身及用电设备的安全。

剩余电流动作断路器具有过载和短路保护功能, 可用来保护线路或电动机的过载和短路, 亦可在正常情况下作为线路的不频繁转换启动之用。符合标准:GB 16917.1,IEC 61009-1。

The DZ47LE residual current operated circuit breaker is applicable to the circuit with an alternating current of 50Hz, rated-voltage single pole and two lines/two poles 230V, three poles/three poles and four lines/four poles 400V, and a rated current up to 63A; when the human body gets an electric shock or the network leak current exceeds the specified value, the residual current operated circuit breaker can rapidly cut off the power supply in trouble within a very short time for the safety of the human body and the powered equipment. With the function of overload and short circuit protection, the residual current operated circuit breaker can be used to protect the circuit or motor from being damaged by overload and short circuit, and can also be used for not-frequent operational transformation in the circuit under normal condition. The product meets the standards of IEC 61009-1.

正常工作条件 Normal operating conditions

- 环境温度-5 ~40 , 24h内平均不超过35。
- 海拔高度: 安装地点的海拔不超过2000m。
- 安装类别: 、 级。
- 污染等级: 2级。
- 安装方式: 采用TH35-7.5型钢安装轨安装。
- 安装条件: 安装场所的外磁场任何方向均不应超过地磁场的5倍; 剩余电流动作断路器应垂直安装, 手柄向上为接通电源位置; 安装处应无显著冲击和振动。
- 接线方式: 用螺钉压紧接线。
- Ambient air temperature: -5°C~+40°C, the mean value is no greater than +35°C within 24 hours.
- Altitude: not higher than 2000m for the installation site.
- Installation category: II, III grade.
- Pollution degree: 2.
- Installation: TH35-7.5 DIN rail
- Installation conditions: external magnetic field in any direction installation site should not exceed five times the Earth's magnetic field; residual current operated circuit breakers should be installed vertically, the handle for the power-up position; installation should be no significant impact and vibration.
- Connection: screw pinch wiring.

剩余电流动作的分断时间见表1

Maximum breaking time of the residual current operating

表1 Table 1

In(A)	I _n (A)	剩余电流等于下列值时分断时间(s)					
		I _n	2I _n	5I _n	5A,10A,20A,50A, ^{a)} 100A,200A,500A	I _t ^{b)}	
6-63	0.03,0.05,0.1,0.3	0.1	0.05	0.04	0.04	0.04	0.04

注: a. 5A, 10A, 20A, 50A, 100A, 200A, 500A的试验仅对验证动作时进行, 对大于过电流瞬时脱扣范围下限的电流值不进行试验。

b. 在I_t等于C型或D型的过电流瞬时脱扣范围下限的电流值进行试验。

a. The test of 5A, 10A, 20A, 50A, 100A, 200A, 500A is only performed for the verification of operation, and is not performed for the magnitude of current greater than the lower limit of the over-current instantaneous tripping range.

b. The test is carried out for the current with the I_{tn} being equal to the lower limit of the over-current instantaneous tripping range for type C or D.

过电流保护特性见表2

For the over current protection characteristics (see table2)

表2 Table 2

序号 No.	额定电流In(A) Rated current	起始状态 Initial state	试验电流 Test current	规定时间t Time limit	预期结果 Expected result	备注 Remarks
1	6-63	冷态 Cold state	1.13In	t > 1h	不脱扣 No tripping	
2	6-63	紧接前项试验进行 Right after test No.1	1.45In	t < 1h	脱扣 Tripping	电流在5s内稳定上升到规定值
3	6-63	冷态 Cold state	2.55In	1s < t < 60s 1s < t < 120s	脱扣 Tripping	In > 32A
4	6-63	冷态 Cold state	5In	t < 0.1s	不脱扣 No tripping	C型 C type
			10In	t < 0.1s	脱扣 Tripping	
			10In	t < 0.1s	不脱扣 No tripping	D型 D type
			16In	t < 0.1s	脱扣 Tripping	

机械电气寿命:

- a. 电气寿命: 2000次, COS =0.85 ~ 0.9;
- b. 机械寿命: 2000次;
- c. 操作频率: In < 25A 240次/h; In > 25A 120次/h;

Mechanical/Electrical Life

- a. Electrical life: no less than 2,000 times
- b. Mechanical life: no less than 2,000 times
- c. Operating Frequency: In < 25A 240 times / h; In > 25A 120 times / h;

绝缘耐冲击电压性能

- a. 各极连接在一起与中性极之间能承受峰值为6000V的冲击电压;
- b. 各极与中性极连接在一起和金属支架之间能承受峰值为8000V的冲击电压。

Insulation shock-resistance voltage performance

- a. The impulse voltage with a peak value of 6,000V can be withstood between the various poles connected together and the neutral pole;
- b. The impulse voltage with a peak value of 8,000V can be withstood between the various poles connected with the neutral pole and the metal support;
- The residual current operated circuit breaker has the capability of withstanding the impact of the surge current with a peak current of 200A without causing misoperation;

脱扣特性曲线图(见图1)。Characteristic curve(See Fig.1)



图1 C型 Fig.1 C type

图1 D型 Fig.1 D type

接线螺钉扭矩应不小于1.5N·m;

Suitable for the connection of leads of less than 1.5N.m

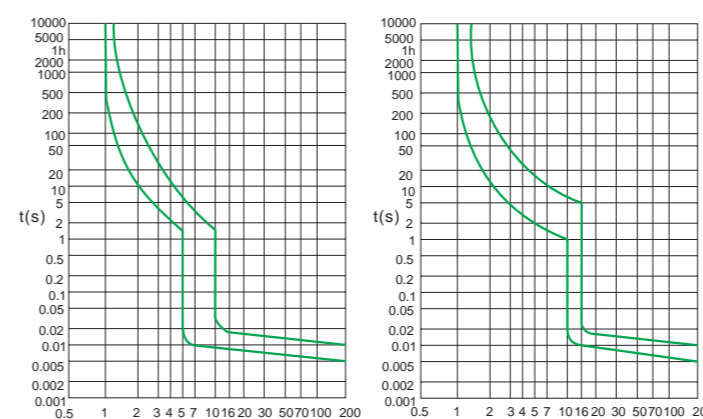
周围空气温度: Ambient air temperature:

周围空气温度最高温度40 最低不低于-5 , 24h平均不超过+35 , 周围空气温度对断路器的影响见表3。

Ambient air temperature up to 40°C minimum temperature is not lower than -5°C, 24h average does not exceed + 35°C, the surrounding air temperature of the circuit breaker in Table 3.

表3 Table 3

温度 Temperature	-15	-5	0	10	20	30	40	55
额定电流修正系数	1.19	1.15	1.13	1.06	1.05	1	0.96	0.89

安装铜导线选型见表4

Nominal cross-sectional area of the copper conductor

表4 Table 4

额定电流In(A) Rated current	铜导线标称截面积(mm ²) Nominal cross-sectional area of the copper conductor
10及以下	1.5
10-20	2.5
20-25	4
25-32	6
32-50	10
50-63	16

外形及安装尺寸 Outline & installation size

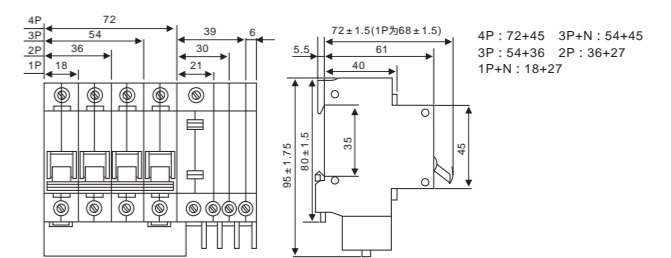

DZ47LE-32

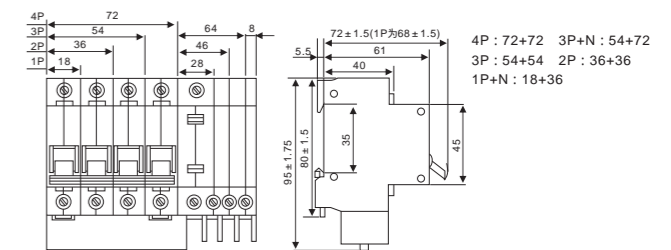

DZ47LE-63

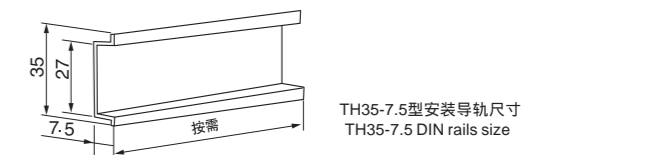

订货须知 Ordering information

订货时要标明下列各点:

- 产品型号和名称, 如: 壳架等级额定电流为63A, 产品型号名称为DZ47LE-63剩余电流动作断路器;
- 额定电流, 如: 30A;
- 瞬时脱扣器类型, 如: C型;
- 额定剩余动作电流, 如: 0.03A;
- 订货数量, 如: 50台;
- 订货举例DZ47LE-63剩余电流动作断路器, C50, 单极二线, 0.03A, 50台。

When ordering the goods, the user shall indicate the following items:

- Types and names of products, for example, DZ47LE series residual current operated circuit breaker
- Instantaneous tripping type and rated current, for example, C50;
- Number of poles: for example, 2P;
- Rated residual operating current: for example, 0.03A;
- Quantity on order, for example, 50 units;
- Example for ordering: DZ47LE-32 residual current operated circuit breaker, 2P, 0.03A, C50, 50 units.

DZ47LE-125

系列剩余电流动作断路器

Series Residual Current Operated Circuit Breaker



型号及其含义 Code and implication

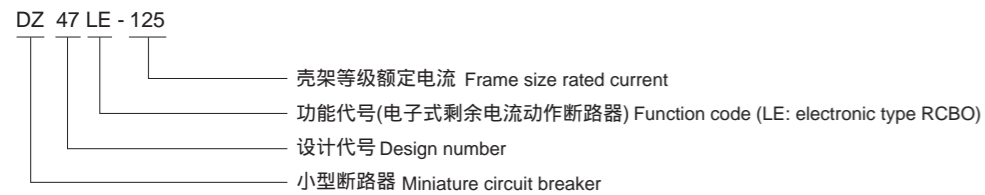

主要参数及技术性能 Main technical data

分类 Main specifications

- 极数：单极两线(1P+N)、两极(2P)、三极(3P)、三极四线(3P+N)、四极(4P)；
- 短路脱扣特性：(8~12)I_n。
- Poles: 1P + N, 2P, 3P, 3P + N, 4P;
- Short circuit tripping characteristics: (8 ~ 12) I_n.

主要技术参数 Technical parameters

- 额定电压U_e(V): 单极两线、两极：230；
三极、三极四线、四极：400；
- 额定电流I_n(A): 63、80、100、125。
- 壳架等级额定电流I_{nm}(A): 125；
- 额定剩余动作电流I_n(A): 0.03、0.1、0.3；
- 额定剩余不动作电流I_{no}(A): 0.5I_n；
- 额定短路分断能力I_{cu}(A): 6000；
- 额定剩余接通和分断能力I_m(A): 2000；
- 剩余电流动作的分断时间(见表1)。
- Rated voltage U_e (V): 1P+N, 2P: 230;
3P, 3P+N, 4P: 400;
- Rated current I_n (A): 63, 80, 100, 125.
- Frame rated current I_{nm} (A): 125;
- Rated residual operating current I_n (A): 0.03, 0.1, 0.3;
- Rated residual non-operating current I_{no} (A): 0.5I_n;
- Rated short-circuit breaking capacity I_{cu} (A): 6000;
- Rated residual making and breaking capacity I_m (A): 2000;
- Residual current breaking time (see Table 1).

适用范围 Application

DZ47LE-125剩余电流动作断路器适用于交流50Hz, 额定电压单极两线、两极230V, 三极、三极四线、四极400V, 额定电流从63A至100A的线路中, 当人身触电或电网泄漏电流超过规定值时, 剩余电流动作断路器能够在极短的时间内迅速切断故障电源, 保护人身及用电设备的安全, 同时可以保护线路和电动机的过载或短路, 亦可作为线路的不频繁转换及电动机的不频繁启动之用。符合标准: GB14048.2和IEC 60947-2。

The DZ47LE residual current operated circuit breaker is applicable to the circuit with an alternating current of 50Hz, rated-voltage single pole and two lines/two poles 230V, three poles/three poles and four lines/four poles 400V, and a rated current 63~125A; when the human body gets an electric shock or the network leak current exceeds the specified value, the residual current operated circuit breaker can rapidly cut off the power supply in trouble within a very short time for the safety of the human body and the powered equipment. With the function of overload and short circuit protection, the residual current operated circuit breaker can be used to protect the circuit or motor from being damaged by overload and short circuit, and can also be used for not-frequent operational transformation in the circuit under normal condition.

The product meets the standards of GB14048.2 and IEC60947-2.

正常工作条件 Normal operating conditions

- 环境温度-5 ~40℃, 24h内平均不超过35℃。
- 海拔高度：安装地点的海拔不超过2000m。
- 安装类别：Ⅲ级。
- 污染等级：3级。
- 安装方式：采用TH35-7.5型钢安装轨安装。
- 安装条件：安装场所的外磁场任何方向均不应超过地磁场的5倍；剩余电流动作断路器应垂直安装，手柄向上为接通电源位置；安装处应无显著冲击和振动。
- Ambient air temperature: -5℃~+40℃, the mean value is no greater than +35℃ within 24 hours.
- Altitude: not higher than 2000m for the installation site.
- Installation category: III grade.
- Pollution degree: 3.
- Installation: TH35-7.5 DIN rail
- Installation conditions: external magnetic field in any direction installation site should not exceed five times the Earth's magnetic field; residual current operated circuit breakers should be installed vertically, the handle for the power-up position; installation should be no significant impact and vibration.

表1 Table 1

序号 No.	I _n (mA)	最大分断时间(s)和最小不驱动时间(s) The maximum breaking time (s) and not the minimum driving time (s)			
		I _n	2I _n	5I _n	10I _n
一般型	30	0.1	0.06	0.04	0.04

- 过电流保护特性(见表2)。
For the over current protection characteristics (see table2)

表2 Table 2

起始状态 Initial state	试验电流 Test current	规定时间Time limit		预期结果 Expected result	备注 Remarks
		I _n =63A	I _n > 63A		
冷态 Cold state	1.05I _n	t 1h	t 2h	不脱扣 No tripping	
紧接着前项试验后进行 Right after test number a	1.30I _n	t < 1h	t < 2h	脱扣 Tripping	电流在5s内稳定上升到规定值 The current is rising within 5s
冷态 Cold state	8I _n	t 0.2s		不脱扣 No tripping	通过闭合辅助开关接通电流 The power supply is turned on by closing the auxiliary switch
冷态 Cold state	12I _n	t < 0.2s		脱扣 Tripping	

- 机械电气寿命：
 - 电气寿命：1500次, cos φ=0.85~0.9；
 - 机械寿命：8500次；
- 绝缘耐冲击电压性能：U_{imp}(V) :4000；
- 剩余电流动作断路器在峰值电流为200A冲击电流和峰值电压为4000V浪涌过电压作用下, 具有承受能力, 且不起误动作。
- Mechanical/Electrical Life
 - Electrical life: no less than 1,500 times
 - Mechanical life: no less than 8,500 times
- Insulation shock-resistance voltage performance: U_{imp}(V) :4000;
- The residual current operated circuit breaker has the capability of withstanding the impact of the surge current with a peak current of 200A without causing misoperation;

- 脱扣特性曲线图(见图1)。Characteristic curve(See Fig.1)



图1 Fig.1

其它 Others

主要结构和工作原理

- 结构：

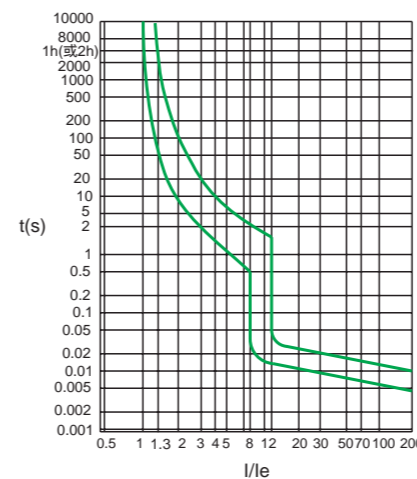
剩余电流动作断路器由DZ47-125塑料外壳式断路器和剩余电流脱扣器组成而成。

DZ47-125塑料外壳式断路器主要由绝缘外壳, 操作机构、动静触头, 延时、瞬时脱扣器、灭弧室等组成。

剩余电流脱扣器主要由零序互感器、电子判别控制电路、脱扣器推杆, 试验按钮等组成。塑料外壳式断路器与剩余电流脱扣器之间通过推杆进行联动。
- 工作原理：

将剩余电流动作断路器手柄扳向ON位置时, 通过机械机构带动动触头向静触头运动并与静触头可靠接触, 接通电路。当线路发生过载故障时, 过载电流使热双金属元件弯曲并推动杠杆使得机械锁定机构复位, 动触头迅速离开静触头, 从而实现分断线路的功能; 当线路发生短路故障时, 短路电流使瞬时脱扣器动作, 铁心顶杆推动杠杆使得锁定机构复位, 实现分断功能。当线路发生剩余电流或触电故障时, 零序互感器输出的信号触发可控硅导通, 使剩余电流脱扣器铁心动作, 推杆推动断路器脱扣, 使剩余电流动作断路器在极短时间内切断电源, 从而实现剩余电流保护功能。

The main structure and working principle

- Structure

RCCB composed of DZ47-125 moulded case circuit breaker and residual current tripping device

DZ47-125 moulded case circuit breaker consists of insulated shell, operating mechanism, moving and static contacts, time delay release and instantaneous release, arc quenching chamber and etc.

Residual current tripping device made of zero sequence current transformer, electronic control circuit, push rod of release, test button and etc. the interconnection between circuit breaker and release is executed through the push rod.
- Working theory

when to push the handle of RCCB to ON position, drive moving contact to static being reliably closed through mechanism, the circuit is closed. When the line has overloading fault, overloading current will make thermal bimetal element to be bent and push lever to reset the mechanical lock, the moving contact disconnected from static contact quickly, now the circuit is opened; when the line has short circuit fault, the short circuit current will drive instantaneous release to trip immediately, the rod of iron core push the mechanical lock to reset, to realize the circuit being opened. when the line has residual current fault or electric shock, zero-sequence CT produce a signal to make controllable silicon to be connected, then drive iron core of residual current release to trip, push the rod of circuit breaker to trip quickly, namely achieve the residual current protection function.

接线 Wiring

适用于(10~50)mm²导线连接, 接线端子拧紧力矩不大于3.5N·m。安装前应选择合适的导线将剩余电流动作断路器接入线路中, 推荐导线的截面积见表3, 并检查剩余电流动作断路器与所使用的正常工作条件是否相符。

Suitable for the connection with (10~50)mm² conductor, the tightened torque not more than 3.5N.m. before to install, please choose the proper conductor to connect RCCB in the line, the recommended sectional area of conductor as table 3, please check if the technical data of RCCB is suitable for the working system or not.

表3 Table 3

额定电流I _n (A) Rated current	铜导线标称截面积(mm ²) Nominal cross-sectional area of the copper conductor
63	16
80	25
100	35

DZ47LE-125

系列剩余电流动作断路器

Series Residual Current Operated Circuit Breaker

产品特点

- 剩余电流动作断路器操作机构为带储能式自由脱扣机构，触点快速闭合，克服了因人力操作手柄速度快慢带来的不利影响，大大提高了产品使用寿命；在正常工作时，触头只能停留在闭合或断开位置。
- 分断能力高，可达6000A。
- 剩余电流脱扣器内的零序互感器、电子判别控制电路元件性能高，工作稳定，抗干扰性强，确保了产品可靠工作。
- 带指触防护组合型接线端子，安全性高。
- 壳体和部件均采用高阻燃、耐高温、耐冲击塑料制成。
- 产品体积小，重量轻，结构紧凑，模块化设计。
- 外型独特，合理的利用了空间布局。
- 产品采用导轨安装，方便省时。

Features

- The operating mechanism of RCCB is energy charged free tripping device, the contacts can be closed quickly, which can avoid the bad influence of unsteady closing speed caused by manually operating the handle, greatly extend the working life, at normal working status, the contact can locate at ON/OFF position.
- High breaking capacity, up to 6000A
- The zero sequence CT, electronic control element of RCCB are very stable, with high performance, strong anti-interference.
- Finger touch proof terminals designed, to achieve high safety.
- The shell and some functional parts made of high flameproof, hi-temperature withstand, impact withstand plastic material.
- Small size, light weight, compact structure, module design
- Peculiar figure, structure design is very excellent
- Rail mounting, easy installation and save time.

应用示例 Application Examples

剩余电流动作断路器在电网中的使用见图。剩余电流动作断路器也可以与其成电器形式组合电器，扩大使用范围。

The use of RCCB in the system see as the picture. The RCCB also can be operated with other device, to perform more functions.

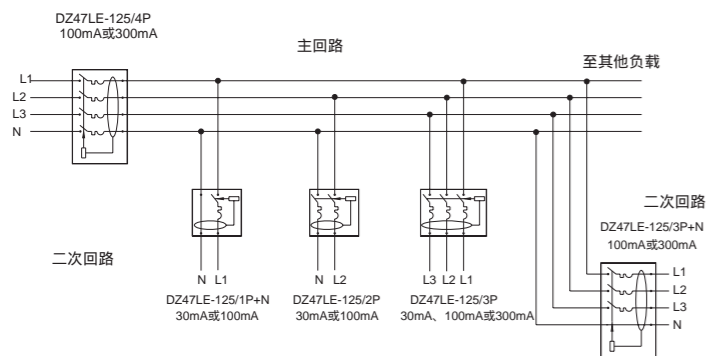

外形及安装尺寸 Outline & installation size

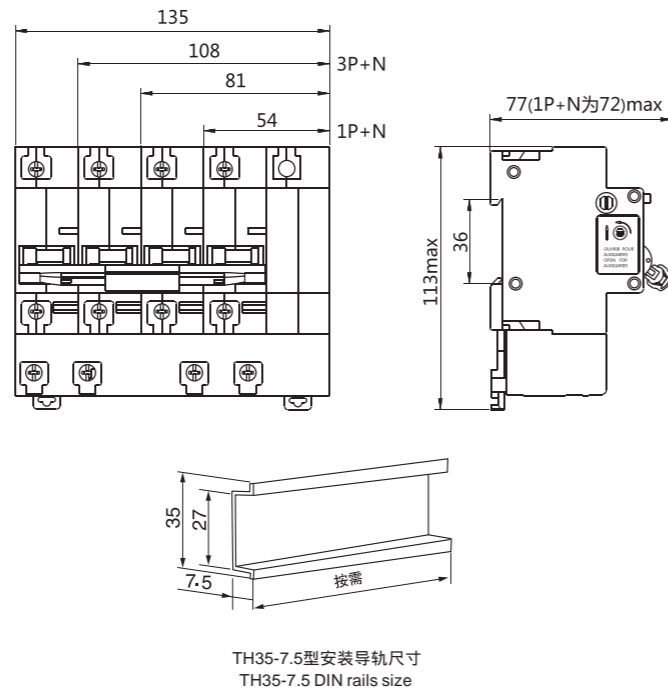

订货须知 Ordering information

订货时要标明下列各点：

- 产品型号和名称DZ47LE-125剩余电流动作断路器；
- 极数，如单极两线；
- 额定电压，230V；
- 额定电流，125A；
- 额定剩余动作电流，100mA；
- 订货数量，50台。

订货举例

例：DZ47LE-125剩余电流动作断路器单极两线230V，125A，100mA，50台。

When ordering the goods, the user shall indicate the following items:

- Types and names of products, for example, DZ47LE-125 series residual current operated circuit breaker
- Number of poles: for example, 2P;
- Rated voltage: for example, 230V;
- Rated current: for example, 125A;
- Rated residual operating current: for example, 100A;
- Quantity on order, for example, 50 units;
- Example for ordering: DZ47LE-125 residual current operated circuit breaker, 230V, 125A, 100mA, 50 units.

DZ30LE-32

系列剩余电流动作断路器

Series Residual Current Operated Circuit Breaker



型号及其含义 Code and implication



主要参数及技术性能 Main technical data

主要规格：

- 按额定电流分：6A, 10A, 16A, 20A, 25A, 32A;
- 按极数为带一个保护极的二极断路器(1P+N);
- 瞬时脱扣器的型式为C型(5In~10In)。

Main specifications

- Graded as follows according to the rated current In: 6A, 10A, 16A, 20A, 25A, 32A;
- Categorized as follows according to the number of poles and current circuit: Single pole and two lines (1P+N)
- Classified as follows according to the type of instantaneous release: C type (5-10) In

主要技术参数 Technical parameters

- 主要技术参数(见表1)。Main Technical parameters see Table1

表1 Table 1

壳架等级额定电流(A) Frame size rated current	极数 Poles	额定电流(A) Rated current	额定电压(V) Rated voltage	运行短路能力(A) Circuit capacity
32	1P+N	6、10、16、20、25、32	230	4500

- 时间 - 电流动作特性(见表2)。For the over current protection characteristics (see table2)

表2 Table 2

序号 No.	脱扣器额定电流In Rated current	起始状态 Initial state	试验电流 Test current	规定时间 Time limit	预期结果 Expected result	备注 Remarks
a	32A	冷态 Cold state	1.13In	t 1h	不脱扣 No tripping	
b		紧接着a项试验后进行 Right after test number a	1.45In	t < 1h	脱扣 Tripping	电流在5s内稳定地上升至规定值 The current is rising within 5s
c		冷态 Cold state	2.55In	1s < t < 60s	脱扣 Tripping	
d		冷态 Cold state	5In	t 0.1s	不脱扣 No tripping	通过闭合辅助开关接通电流 The power supply is turned on by closing the auxiliary switch
e		冷态 Cold state	10In	t < 0.1s	脱扣 Tripping	

适用范围 Application

DZ30LE-32剩余电流断路器(以下简称剩余电流动作断路器)主要适用于交流50Hz或60Hz, 额定电压230V, 额定电流至32A的电路中, 作为人身触电、设备漏电保护之用, 并且有过载、短路保护功能, 也可以在正常情况下不频繁地通断电器装置和照明线路, 尤其适用于工业和商业照明配电系统。当需要时可以增加过电压保护功能, 过压保护额定值Uvo=280V。符合标准: GB 16917.1、IEC 61009-1。

DZ30LE-32 residual current circuit breaker (hereinafter call RCCB) is mainly operating in the line of AC 50/60HZ, rated voltage 230V, rated current up to 32A, used to protect from electric shock, electric leakage of equipment, also prevent overloading, short circuit, also to switch on/off electric devices or light system non-frequently, especially suitable for industrial and commercial lighting system. If necessary, over-voltage protection can be added, o/v value Uvo=280V. The product complies with GB 16917.1、IEC 61009-1 standards.

正常工作条件 Normal operating conditions

- 环境温度-5 ~40℃, 24h内平均不超过35℃。
- 海拔高度: 安装地点的海拔不超过2000m。
- 安装类别: II、III级。
- 污染等级: 2级。
- 安装方式: 采用TH35-7.5型钢安装轨安装。
- Ambient air temperature: -5°C~+40°C, the mean value is no greater than +35°C within 24 hours.
- Altitude: not higher than 2000m for the installation site.
- Installation category: II, III grade.
- Pollution degree: 2.
- Installation: TH35-7.5 DIN rail

DZ30LE-32

系列剩余电流动作断路器

Series Residual Current Operated Circuit Breaker

- 剩余电流保护特性：
 - 额定剩余动作电流 I_n : 0.03A;
 - 额定剩余不动作电流 I_{no} : 0.015A;
 - 额定剩余接通和分断能力 I_m : 500A;
 - 剩余电流动作的分断时间 (见表3)。
- Residual current protection characteristic:
 - Rated residual operating current I_n : 0.03A;
 - Rated residual non-operating current I_{no} : 0.015A;
 - Rated residual making and breaking capacity I_m : 500A;
 - Residual current breaking time (Table 3).

表3 Table 3

In(A)	I _n (A)	剩余电流等于下列值时分断时间(s) Breaking time when the residual current assumes the following values (s)			
		I _n	2I _n	5I _n	500A
6-32	0.03	0.1	0.08	0.04	0.04

- 过电压保护：U_{vo}=280V±14V(需要时)。
- 机械电气寿命：

剩余电流动作断路器能承受4000次操作循环，其中电气寿命为2000次。
- 接线：剩余电流动作断路器使用时参照表4选取铜导线截面积。
- Overvoltage protection: U_{vo} = 280V ± 14V
- Mechanical and electrical life:

Mechanical life: 4,000 times, Electrical life: 2000 times.
- Wiring: using residual current operated circuit breaker see Table 4 select copper wire cross-sectional area.

表4 Table 4

额定电流In(A) Rated current	In 6	6 < In 13	13 < In 20	20 < In 25	25 < In 32
导线截面积S(mm ²) Nominal cross-sectional area of the copper conductor	1	1.5	2.5	4	6

- 脱扣特性曲线图(见图1)。Characteristic curve(See Fig.1)



图1 Fig.1

结构特征 Structural features

- 产品体积小，结构紧凑，价格优于同类产品。
- 产品壳体和部分功能件均采用高阻燃、耐高温、耐冲击塑料制成。
- 产品直接带零线安装，避免零线接线错误潜在的触电危险。
- 产品采用最新电路设计和高性能元件，在冲击电流和浪涌电压时，具有较强的承受能力，不引起误动作。
- 产品采用导轨安装，方便省时。
- Small size, compact structure. the price is cheaper than other same product
- The shell and some functional parts made of high flameproof, hi-temperature withstand, impact withstand plastic material.
- The product directly connected with neutral line, to avoid wrong connection and leading to electric shock.
- The product adopted the latest circuit design and hi-performance components, it can withstand high surging current and over-voltage and avoid wrong tripping.
- Rail mounting, easy installation and save time.

外形及安装尺寸 Outline & installation size

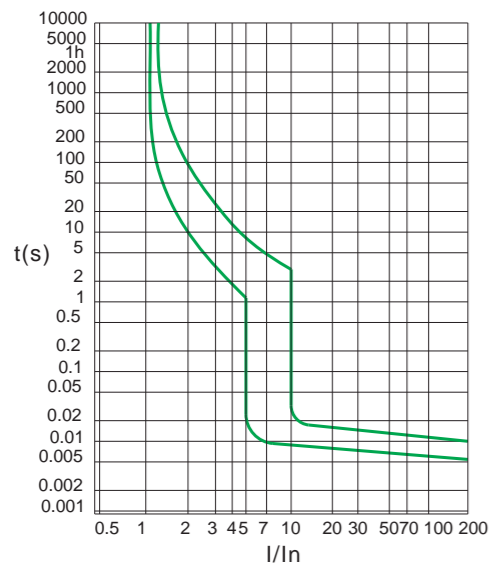
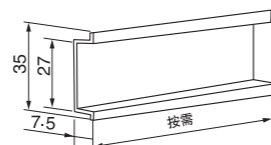
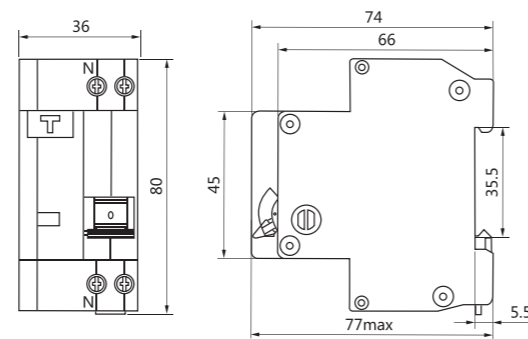

TH35-7.5型安装导轨尺寸
TH35-7.5 DIN rails size

订货须知 Ordering information

订货时要标明下列各点：

- 产品型号和名称，DZ30LE-32剩余电流动作断路器；
- 瞬时脱扣器类型和额定电流如C20(照明保护型额定电流20A)。
- 当需要过压保护时，必须注明。
- 订货数量，500台；
- 订货举例DZ30LE-32剩余电流动作断路器C20,500台。

When ordering the goods, the user shall indicate the following items:

- Types and names of products, for example, DZ30LE-32 residual current operated circuit breaker
- Instantaneous tripping type and rated current, for example, C20;
- Quantity on order, for example, 500 units;
- Example for ordering: DZ30LE-32 residual current operated circuit breaker, C50, 500 units.

ZM30LE-63

系列剩余电流动作断路器

Series Residual Current Operated Circuit Breaker



型号及其含义 Code and implication



正常工作条件 Normal operating conditions

- 周围空气温度上限值不超过+40，下限值不低于-5，且24h的平均温度不超过+35；

注：在周围空气温度高于+40或低于-5的条件下使用的漏电断路器应于制造厂协商；
- 海拔高度：安装地点的海拔不超过2000m；
- 大气相对湿度在周围空气温度为+40时不超过50%，在较低温度下可以允许有较高的相对湿度，例如在+20时达90%，对由于温度变化偶尔产生的凝露应采取适当的措施；
- 污染等级：2级；
- 安装类别：Ⅱ、Ⅲ级；
- 安装场所的外磁场任何方向不应超过地磁场的5倍；
- 安装位置应垂直，各方向的倾斜度不超过10°；
- 安装处应无显著冲击和振动无雨雪侵袭。
- Ambient air temperature: -5°C~+40°C, the mean value is no greater than +35°C within 24 hours.

Note: If the upper limit is higher than +40°C or lower limit lower than -5°C in work, discussions shall be made between the user and the manufacturer.
- Altitude: not higher than 2000m for the installation site.
- When the ambient air temperature is +40°C, the relative humidity of the air shall not be higher than 50%; a higher relative humidity is allowed at a lower temperature; for example, for the wettest month, the maximum relative humidity averaged shall be 90% while the lowest temperature averaged in that month +20°C, and special measures shall be taken for the condensation occasionally produced due to temperature change.
- Class of Pollution: 3
- Installation category: II, III
- The ambient air is not significantly polluted by dust, smoke, corrosive and/or flammable gases, vapours or salt.

适用范围 Application

ZM30LE-63系列剩余电流断路器主要适用于交流50Hz，额定工作电压230V，额定电流至63A及以下的线路中，用来对人进行间接接触保护，以及对建筑物及类似用途的线路进行过电流保护。也可对由于过电流保护装置不动作而持续存在的接地故障引起的火灾提供保护。

ZM30LE-63系列漏电断路器在低压配电系统中已越来越多的地被采用作为接地故障和直接接触、间接接触电击的后备保护。

产品符合GB16917和IEC61009标准。

ZM30LE-63 series leakage circuit breaker is suitable for the circuit of AC 50Hz, rated working voltage 230V and rated current 40A and below, to make indirect contact protection to the human being and protect the circuit against over current in buildings or other similar locations as well, also to prevent fire accident caused by continuous ground fault current due to the damage of over-current protection equipment. In addition, the leakage circuit breaker with over voltage protection can prevent the over voltage caused by fault of power grid. This series of products is more and more used for stand-by protection against ground fault and electric shocks by direct contact and indirect contact in the low voltage distribution system. The products are in conformity with such standards as GB 16917 and IEC61009.

ZM30LE-63

系列剩余电流动作断路器

Series Residual Current Operated Circuit Breaker

结构特征 Structural features

- 本漏电断路器主要由零序电流互感器、电子组件板、漏电脱扣器、操作机构和塑料外壳等组成。
- The earth leakage circuit breaker is mainly composed of zero sequence current transformer, electronic component board, leakage release, operating mechanism And plastic and other components.

主要参数及技术性能 Main technical data

- 漏电断路器的主要技术参数 Main Technical data of Circuit Breaker

表1 Table 1

型号 Type	极数 Pole	加中性线 With neutral line	频率 Hz Frequency	额定电流 In A Rated current	电压 V Rated voltage	额定分断 能力Icn A Rated Breaking capability	额定剩余接通 和分断能力 I _m A Rated residual making and breaking capability	额定剩余动作 电流I _n mA Rated residual action current	额定剩余不动作 电流I _{no} mA Rated residual non-action current	过电流瞬 时脱扣类型 Over-current instantaneous release type
ZM30LE-63	1	N	50	6,10,16,20,25,32 40,50,63	230	3000	1500	30	15	BC

- 过电流脱扣保护特性 For the over current protection characteristics (see table2)

表2 Table 2

过电流瞬时脱扣器类型 Over-current instantaneous release	脱扣器额定电流In Rated current	试验电流 Test current	规定时间 Time limit	预期结果 Expected result	起始状态 Initial state	试验环境温度 Test temperature
B, C	63A	1.13In	t 1h	不脱扣 No tripping	冷态 Cold state	+30
	63A	1.45In	t<1h	脱扣 Tripping	热态 Hot state	
	32A	2.55In	1s<t<60s	脱扣 Tripping	冷态 Cold state	
>32A	1s<t<120s		脱扣 Tripping			
B, C	63A	3In	t 0.1s	不脱扣 No tripping	冷态 Cold state	
B		5In				
C	63A	5In	t<0.1s	不脱扣 No tripping		
C		10In				

外形及安装尺寸 Outline & installation size

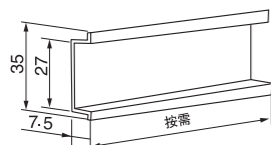
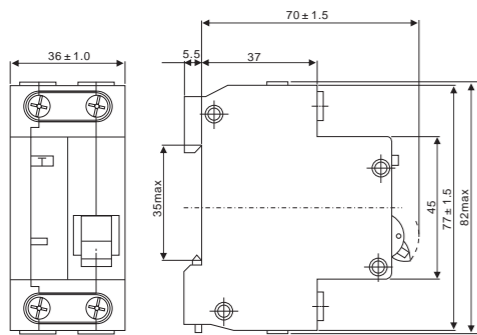

TH35-7.5型安装导轨尺寸
TH35-7.5 DIN rails size

订货须知 Ordering information

订货时要标明下列各点：

- 漏电断路器的名称、型号、规格；
- 漏电断路器的额定电流；
- 漏电断路器的额定剩余动作电流；
- 极数；
- 数量；
- 例ZM30LE-63, C型, 1P+N, 额定电流20A, 额定剩余动作电流30mA, 数量1000台。应写成：ZM30LE-63/1P+N, C20, 30mA, 1000台。

When ordering the goods, the user shall indicate the following items:

- Name, type, specifications of products
- Rated current of Leakage circuit breakers
- Rated residual operating current of Leakage circuit breakers
- Poles of Leakage circuit breakers
- Quantity Leakage circuit breakers
- Example: ZM30LE-63, C-type, 1P + N, rated current 20A, rated residual operating current 30mA, the number of 1000. Should be written: ZM30LE-63 / 1P + N, C20, 30mA, 1000 units.

HL30-100

系列隔离开关

Series Switch Disconnecter



主要参数及技术性能 Main technical data

分类 Main specifications

- 按额定电流Ie分：32A、63A、100A、125A。
- 按极数分：1P、2P、3P、4P。
- Rated Current Ie: 32A, 63A, 100A, 125A.
- Poles: 1P, 2P, 3P, 4P.

主要技术参数 Technical parameters

- 额定绝缘电压Ui: 500V;
- 额定工作电压Ue: 230V(1P)、400V(2P、3P、4P)。
- 额定工作电流Ie: 32A、63A、100A、125A。
- 额定冲击耐受电压Uimp: 4kV(2000m);
- 额定短时耐受电流Icw: 12Ie, 通电时间为1s;
- 额定短路接通能力Icm: 20Ie, 通电时间0.1s;
- 额定接通与分断能力: 3Ie, 1.05Ue, COSφ = 0.65;
- 操作性能: 机械寿命8500次, 电气寿命1500次。
- Rated insulation voltage Ui: 500V;
- Rated operating voltage Ue: 230V (1P), 400V (2P, 3P, 4P)。
- Rated operating current Ie: 32A, 63A, 100A, 125A.
- Rated impulse withstand voltage Uimp: 4kV (2000m);
- Rated short time withstand current Icw: 12Ie, power-on time 1s;
- Rated short-circuit making capacity Icm: 20Ie, power-on time 0.1s;
- Rated making and breaking capacity: 3Ie, 1.05Ue, COS φ = 0.65;
- Operating performance: Mechanical life 8500 times, electrical life 1500 times.

外形及安装尺寸 Outline & installation size

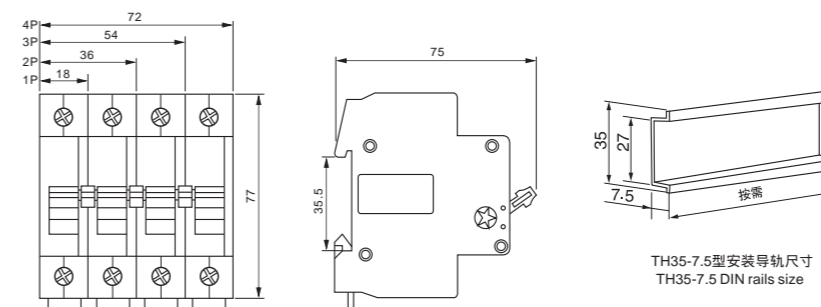

TH35-7.5型安装导轨尺寸
TH35-7.5 DIN rails size

订货须知 Ordering information

订货时须说明：

- 隔离开关的名称、型号；
- 隔离开关的额定电流；
- 隔离开关的极数；
- 数量。
- 订货举例：用户订HL30-100隔离开关，额定电流为63A、3极，数量100台。

When ordering the goods, the user shall indicate the following items:

- Types and names of Switch Disconnecter
- Rated current of Switch Disconnecter
- Poles of Switch Disconnecter
- Quantity
- Example for ordering: HL30-100 switch Disconnecter 63A, 3P, 100 units.

适用范围 Application

HL30-100隔离开关主要作为终端组合电器中的总开关，适用于交流50Hz, 额定电压至400V的配电和控制回路中，也可用于控制电动机、小功率电器和照明，广泛应用于工矿企业、高层建筑、商业及家庭等场所。

符合标准：GB14048.3、IEC60947-3，获得CCC、CE认证。

HL30-100 series switch disconnecter is operating in the distribution and control circuit of AC50Hz, rated working voltage 400V and below, also used to control various asynchronous motors, electric appliances or lighting device with small capacity, widely in mineral enterprises, high buildings, commercial & residential houses.

Applicable standard: GB14048.3, IEC60947-3, Obtained CCC, CE certification.

型号及其含义 Code and implication

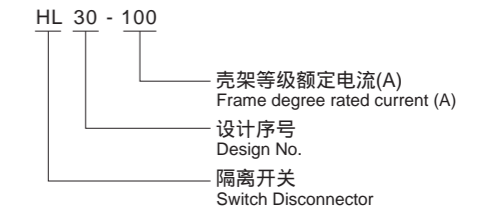

正常工作条件

Normal operating conditions

- 环境温度：-25 ~ +60
- 海拔高度：海拔不超过2000m。
- 污染等级：2级。
- 使用类别：AC-22A、AC-21B。
- 安装类别：、。
- 安装方式：采用TH35-7.5型钢安装轨安装，其安装面与垂直面的倾斜度不超过5°。
- 接线方式：用螺钉压紧接线，100A, 125A 拧紧力矩3.5N.m; 32A, 63A 拧紧力矩2.0N.m
- Ambient air temperature: -25°C~+60°C
- Altitude: not higher than 2000m
- Pollution degree: 2.
- Use category: AC-22A, AC-21B.
- Installation category: II, III
- Installation: TH35-7.5 DIN rail the mounting surface and the vertical gradient of not more than 5°.
- Connection: screw clamping wiring, 100A, 125A torque: 3.5Nm; 32A, 63A torque: 2.0Nm

ZMH3-100

系列隔离开关

Series switch disconnector



主要参数及技术性能 Main technical data

分类 Main specifications

- 按额定电流Ie分：32A、63A。
- 按极数分：1P、2P。
- Rated Current Ie: 32A, 63A.
- Poles: 1P, 2P.

主要技术参数 Technical parameters

- 额定绝缘电压Ui: 500V;
- 额定工作电压Ue: 230V;
- 额定工作电流Ie: 32A、63A;
- 额定冲击耐受电压Uimp: 4kV(2000m);
- 额定短时耐受电流Icw: 12Ie, 通电时间为1s;
- 额定短路接通能力Icm: 20Ie, 通电时间0.1s;
- 额定接通与分断能力: 3Ie, 1.05Ue, COSφ = 0.65;
- 操作性能: 机械寿命8500次, 电气寿命1500次。
- 安装铜导线选型
- Rated insulation voltage Ui: 500V;
- Rated operating voltage Ue: 230V
- Rated operating current Ie: 32A, 63A.
- Rated impulse withstand voltage Uimp: 4kV (2000m);
- Rated short time withstand current Icw: 12Ie, power-on time 1s;
- Rated short-circuit making capacity Icm: 20Ie, power-on time 0.1s;
- Rated making and breaking capacity: 3Ie, 1.05Ue, COS φ = 0.65;
- Operating performance: Mechanical life 8500 times, electrical life 1500 times.

表1 Table 1

额定电流 Rated current Ie(A)	铜导线标称截面积(mm ²) Nominal cross-sectional area
32	6
63	16

外形及安装尺寸 Outline & installation size

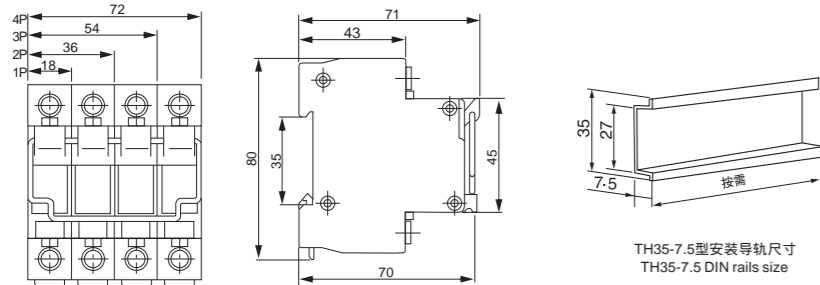

订货须知 Ordering information

- 订货时须说明开关的型号名称、额定电流、开关的极数以及产品数量。
- 如需订购ZMH3-100隔离开关63A、单极产品100台可写成ZMH3-100/1P、63A 100台。
- When ordering the switch model name, rated current, number of poles and the number of product switches.
- To order ZMH3-100 isolating switch 63A, unipolar product 100 can be written ZMH3-100 / 1P, 63A 100 units.

AC30

模数化插座、多功能插座

Module socket, multi-functional sockets



适用范围 Application

AC30系列模数化插座，多功能插座适用于电压230/400V，交流50/60Hz，电流至25A的负载电路中，与终端电器组合配套，广泛用于高层建筑、工矿企业、车站、港口、医院、写字楼、试验室及住宅等场所。

执行标准：单相插座GB1002 三相插座GB1003

ACC30 series module socket, multi-functional sockets are operating in the load circuit of voltage 230/400V, AC50/60Hz, current up to 25A, cooperated with termination device, widely for high buildings, mineral enterprises, station, port, hospital, commercial building, test lab and living apartment and etc.

Executed standard: single phase socket: GB 1002, Three-phase socket Gb1003

适用范围 Application

ZMH3-100隔离开关(以下简称开关)适用于交流50Hz、额定电压230V、额定电流至63A的电阻电路中，主要供无负载情况下接通或断开电路，作线路与电源接通或隔离之用。尤其适合线路检修时有效隔离电源并防止意外合闸，以确保检修人员的操作安全。符合标准：GB14048.3, IEC60947-3, 获得CCC认证。

ZMH3-100 series switch disconnector is operating in the distribution and control circuit of AC50Hz, rated working voltage 230V and below, also used to control various asynchronous motors, electric appliances or lighting device with small capacity, widely in mineral enterprises, high buildings, commercial & residential houses.

Applicable standard: GB14048.3, IEC60947-3, Obtained CCC certification.

型号及其含义 Code and implication

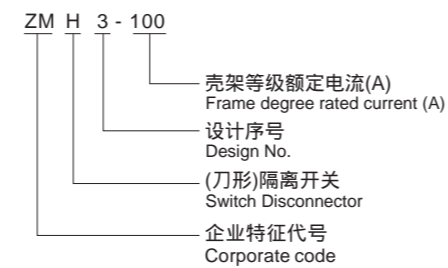

正常工作条件

Normal operating conditions

- 环境温度：-25 ~ +60
- 海拔高度：海拔不超过2000m。
- 污染等级：2级。
- 使用类别：AC-22A。
- 安装类别：、。
- 开关正常为垂直安装(上端为进线)，手柄向上推合，触头接通；往下扳则触头断开，再将手柄上环箍与外壳下端搭勾扣住可避免意外合闸。
- 安装方式：采用TH35-7.5型钢安装轨安装，
- 接线方式：用螺钉压紧接线，拧紧力矩2.0N.m;
- Ambient air temperature: -25°C~+60°C
- Altitude: not higher than 2000m
- Pollution degree: 2.
- Use category: AC-22A
- Installation category: II, III
- Switch normally mounted vertically (upper line), the handle is pushed up together, contact connected; pull down the contacts are open, then the handle on the lower end of the ride and the shell hoop hook fastened to avoid accidental closing.
- Installation: TH35-7.5 DIN rail
- Connection: screw clamping wiring, torque: 2.0Nm

主要技术参数 Main Technical data

型号规格 Model and specification	极数 Pole number	模数/宽度 Module/width	额定电压(V) Rated voltage(V)	额定电流(A) Rated current(A)	类似型号规格 Similar model and specification	备注 Note
ACC30-10/2	2	1/18	230	10	AC30-10/2	二孔插座 Two-hole socket
ACC30-10/3	3	2/36	230/400	10	AC30-10/3	三孔插座 Three-hole socket
ACC30-16/3	3	2/36	230/400	16	AC30-16/3	三孔插座 Three-hole socket
ACC30-16/4	4	3/54	400	16	AC30-16/4	四孔插座 Four-hole socket
ACC30-25/4	4	4/72	400	25	AC30-25/4	四孔插座 Four-hole socket

安装及外形尺寸图 Installation and Dimension Chart

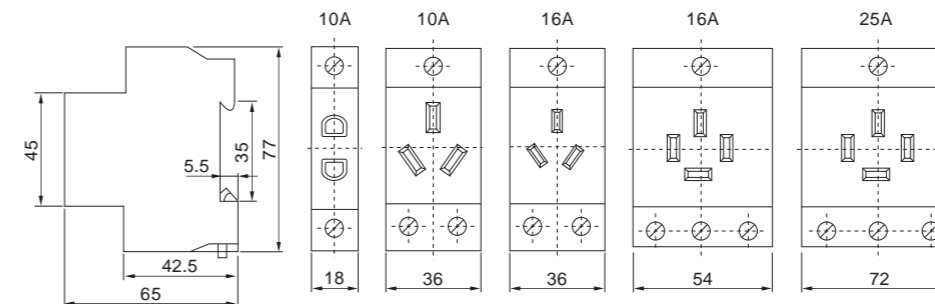

ZMQ3-G

系列自复式过欠压保护器

Series Resettable over-voltage protection



型号及其含义 Code and implication



主要技术参数 Main technical data

参数 Technical Parameters	型号 Model	ZMQ3-G(36宽)				
额定交流电压 Rated AC voltage		220V				
频率 Frequency		50Hz				
通过最大电流 Maximum current		20A	32A	40A	50A	63A
最大负载功率 Maximum load power		4.4KVA	6.6KVA	8.8KVA	11KVA	13.8KVA
过压动作切断值 Over-voltage action cut off value		260~275VAC				
过压恢复值 Overvoltage recovery value		248 ± 5VAC				
欠压动作切断值 Voltage action cut off value		170 ± 5VAC				
欠压恢复值 Voltage recovery value		183 ± 5VAC				
断电后送电延时 Electric power evacuation delay		1~5分钟				
自身功耗 Own power		2W				
电气机械寿命 Electrical Mechanical life		9万次				
外形 Shape		85mmx36mmx66.5mm(长x宽x高)				

参数 Technical Parameters	型号 Model	ZMQ3-G(108宽)						
额定交流电压 Rated AC voltage		380V						
频率 Frequency		50Hz						
通过最大电流 Maximum current		16A	20A	32A	40A	50A	63A	80A
过压动作切断值 Over-voltage action cut off value		460 ± 15VAC						
欠压动作切断值 Voltage action cut off value		300 ± 15VAC						
断电后送电延时 Electric power evacuation delay		1~5分钟						
自身功耗 Own power		2W						
电气机械寿命 Electrical Mechanical life		9万次						
外形 Shape		108mmx85mmx66.5mm(长x宽x高)						

适用范围 Application

ZMQ3-G自复式过欠压延时保护器是我公司根据目前市电状况所研制的新一代家电保护装置，控制线路选用进口元器件组装，产品用模数化标准生产，性能优良、可靠。能在电压异常情况下正常工作。当市电电压超过保护器动作电压时，保护器能迅速、可靠地切断电源，以达到保护电器安全。当市电电压恢复正常时，保护器能自动接通电源、恢复供电，所有功能全部自动实施、无需人员操作。面板上的发光二极管能指示保护器工状况。指示灯发绿光是工作电压指示，指示灯红灯不亮时正常供电，红灯亮时保护功能启动切断供电。本系列产品结构紧凑、外观美观、安装与DZ47(C45)导轨通用。

ZMQ3-G auto-reset over/under voltage time delay protector is a new generation household protective device researched by our company, its control circuit assembled by foreign components, modulus production, high performance, reliability, able to work under abnormal voltage. When the system voltage exceed the tripping value, the protector can cut off power source quickly and reliably, to protect the electric consumers. When the system voltage recover, the protector automatically switch on power source without manual operation. Diode indicator in the panel show the working status of protector, when indicator show green light, it shows the operating voltage, the red lamp does not light, the power supply work normally, when red lamp light, the protector take action to cut off power supply. This product has the features of compact structure, good figure, to be mounted on the rail same as DZ47(C45).

外形及安装尺寸

Outline & installation size

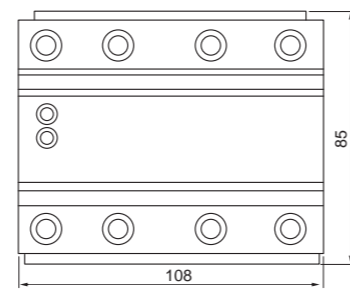
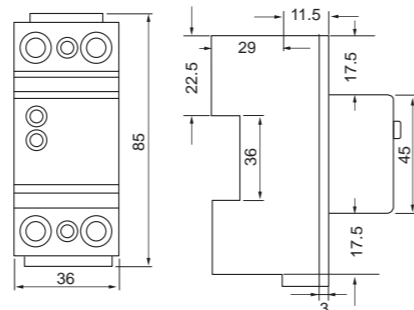

ZMQ4-G

系列自复式过欠压保护器

Series Resettable over-voltage protection



型号及其含义 Code and implication



主要技术参数 Main technical data

规格 Specification	额定电流 In(A) Rated current	额定电压 (V) Rated voltage	额定频率 (Hz) Rated Frequency	过压启动值 (V) Overvoltage start value	常压恢复值 (V) Voltage recovery value	欠压启动值 (V) Undervoltage start value
二相过欠压 Two-phase over-voltage	32,40,50,63 80,100	230AC	50	275 ± 5	240~260	160 ± 5
三相过欠压 + 缺相 Three-phase over-voltage + phase loss		380AC		460 ± 10	420~440	300 ± 100
三相四线过欠压 + 缺相 Three-phase four-wire over-voltage + phase loss						

规格 Specification	常压恢复值 (V) Voltage recovery value	过欠压启动时间(S) Over-voltage start-up time	自身功耗 (W) Power consumption	电气机械寿命 Electrical mechanical life
二相过欠压 Two-phase over-voltage	190 ± 5	60s	<1	>10万次
三相过欠压 + 缺相 Three-phase over-voltage + phase loss	335 ± 10		<2	
三相四线过欠压 + 缺相 Three-phase four-wire over-voltage + phase loss				

适用范围 Application

ZMQ4-G自复式过欠压延时保护器适用于交流50Hz，额定电压400V，额定工作电流125A及以下的用户或负载，作为由中性线故障引起的过欠电压对单相，三相用电设备的保护。

主要用于住宅分户箱进线或需要保护的用电设备的配电或线路的保护。

ZMQ4-G self-reset over/under voltage delay protector is suitable for the distribution line of AC 50Hz, rated voltage 400V, rated operating current 125A and below, to protect single-phase, three-phase electric equipment against over/under voltage caused by neutral line fault, mainly in the incoming line of living users or the distribution line of the equipment where it needs

正常工作条件

Normal operating conditions

- 海拔高度：海拔不超过2000m。
- 允许使用温度范围：-40°C~+50°C
- 空气相对湿度 85%
- 本产品为TH35mm导轨安装
- Ambient air temperature: -40°C~+50°C
- Altitude: not higher than 2000m
- Relative humidity: 85%
- Installation: TH35-7.5 DIN rail

外形及安装尺寸

Outline & installation size

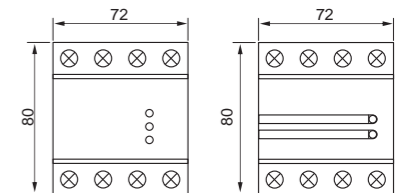

ZMQ5-G

系列自复式过欠压保护器

Series Resettable over-voltage protection



型号及其含义 Code and implication



主要技术参数 Main technical data

规格 Specification	额定电流 In(A) Rated current	额定电压 (V) Rated voltage	额定频率 (Hz) Rated Frequency	过压启动值 (V) Overvoltage start value	常压恢复值 (V) Voltage recovery value	欠压启动值 (V) Undervoltage start value
二相过欠压 Two-phase over-voltage	32,40,50,63 80,100	230AC	50	275 ± 5	240~260	160 ± 5
三相过欠压 + 缺相 Three-phase over-voltage + phase loss		380AC		460 ± 10	420~440	300 ± 100
三相四线过欠压 + 缺相 Three-phase four-wire over-voltage + phase loss						

规格 Specification	常压恢复值 (V) Voltage recovery value	过欠压启动时间(S) Over-voltage start-up time	自身功耗 (W) Power consumption	电气机械寿命 Electrical mechanical life
二相过欠压 Two-phase over-voltage	190 ± 5	60s	<1	>10万次
三相过欠压 + 缺相 Three-phase over-voltage + phase loss	335 ± 10		<2	
三相四线过欠压 + 缺相 Three-phase four-wire over-voltage + phase loss				

适用范围 Application

ZMQ5-G自复式过欠压延时保护器适用于交流50Hz, 额定电压400V, 额定工作电流125A及以下的用户或负载, 作为由中性线故障引起的过欠电压对单相, 三相用电设备的保护。

主要用于住宅分户箱进线或需要保护的用电设备的配电或线路的保护。

ZMQ5-G self-reset over/under voltage delay protector is suitable for the distribution line of AC 50Hz, rated voltage 400V, rated operating current 125A and below, to protect single-phase, three-phase electric equipment against over/under voltage caused by neutral line fault, mainly in the incoming line of living users or the distribution line of the equipment where it needs

正常工作条件

Normal operating conditions

- 海拔高度: 海拔不超过2000m。
- 允许使用温度范围: -40°C~+50°C
- 空气相对湿度 85%
- 本产品为TH35mm导轨安装
- Ambient air temperature: -40°C~+50°C
- Altitude: not higher than 2000m
- Relative humidity: 85%
- Installation: TH35-7.5 DIN rail

外形及安装尺寸

Outline & installation size

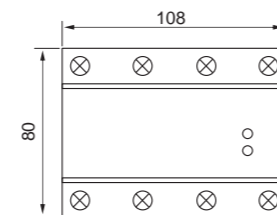
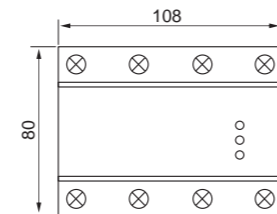

ZMP1-10/20/40/60/80

电源电涌保护器

Series surge protection device



主要技术参数 Main technical data

型号规格 Model and specification	ZMP1-20			ZMP1-40			ZMP1-60			ZMP1-80		
额定工作电压 Un(AC) Rated working voltage Un(AC)	275V	385V	420V	275V	385V	420V	275V	385V	420V	275V	385V	420V
最大持续工作电压 Uc(VAC) Maxi continuous operating voltage	275V	385V	420V	275V	385V	420V	275V	385V	420V	275V	385V	420V
电压保护水平 Up(kV) Voltage protective level	1.2kV	1.8kV	1.9kV	1.4kV	2.0kV	2.1kV	1.4kV	2.2kV	2.3kV	1.6kV	2.4kV	2.5kV
标称放电电流(8/20 μs)In(kA) Nominal discharging current	10			20			30			40		
最大放电电流(8/20 μs)Imax(kA) Maxi discharging current	20			40			60			80		
响应时间ns Response time	<25											
测试级别 Test level	II级 II Level											
宽度mm width	18											
颜色Color	灰色 / 橘色 Grey/Orange											
防护等级 Protection grade	IP20											
外壳材料 Shell material	增强阻燃PBT Reinforced Flame Retardant PBT											
环境温度 Ambient temperature	-40°C~+85°C											
熔断器或断路器(A) Fuse or circuit breaker(A)	20A			25A			32A			32A		
联线规格 Wire Specifications	相线/零线 Phase/Zero line			2.5~35mm ²								
	地线 Wire			4.0~35mm ²								
	信号线 The signal line			1.5mm ²								

外形及安装尺寸 Outline & installation size

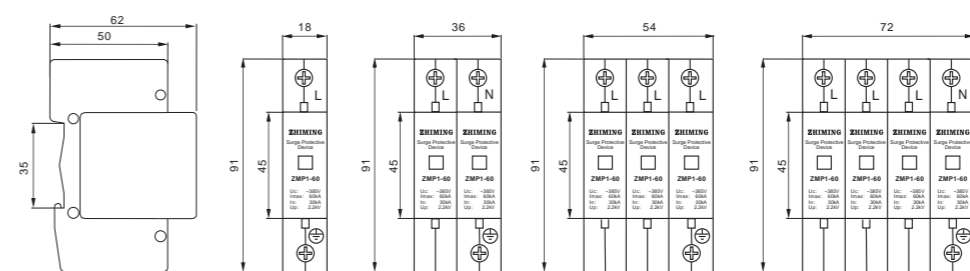

适用范围 Application

ZMP1系列电涌保护器(以下简称SPD)适用于交流50/60Hz, 400V及以下的IT、TT、TN-C、TN-S、TN-C-S, 等供电系统, 对间接雷电和直接雷电影响或其它瞬时过电压的电涌进行保护。

ZMP1 series surge protective device (hereinafter called SPD) is suitable for the IT, TT, TN-C, TN-S, TN-C-S and etc power supply system of AC 50/60Hz, rated voltage 400V and below, to protect from direct and indirect lightning impulse and other transient over voltage.

型号及其含义 Code and implication

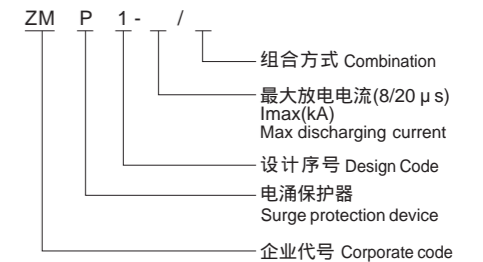

安装 Installation

- 安装在LPZ1 或LPZ2区与LPZ3 区交界处, 采用35mm的标准导轨安装, 连接铜质多股软线为2.5~35mm²。
- 通常安装在进线低压主配电柜处。
- 接地线应采用4mm²以上的双色导线, 长度不得超过500mm。
- 为了防止电涌保护器失效后影响电网正常运行, 联于L线保护器应该串联一个熔断器或断路器(注: 依据标称电涌选择)。

- To be mounted between LPZ1 or LPZ2 zone and LPZ3 zone, adopts 35mm standard mounting rail. The cross sectional area of multi-strand soft copper conductor: 2.5~35 mm².
- Generally it shall be mounted in the incoming side of main distribution panel or box.
- Earthing wire shall be of 4mm² dual color conductor, its length not more than 500mm.
- In order to eliminate the influence on normal service of power network due SPD is invalid, it shall add fuse or breaker to be series connected in L line. (NB: selected according to standard current In)

ZMP1-100

电源电涌保护器

Series surge protection device



主要技术参数 Main technical data

型号规格 Model and specification	ZMP1-100		
额定工作电压 Un(AC) Rated working voltage Un(AC)	275V	385V	420V
最大持续工作电压 Uc(VAC) Maxi continuous operating voltage	275V	385V	420V
电压保护水平 Up(kV) Voltage protective level	2.0kV	2.5kV	2.6kV
标称放电电流(8/20 μs)In(kA) Nominal discharging current	60		
最大放电电流(8/20 μs)Imax(kA) Maxi discharging current	100		
响应时间ns Response time	<25		
测试级别 Test level	II级 II Level		
宽度mm width	27		
颜色Color	灰色 Grey		
防护等级 Protection grade	IP20		
外壳材料 Shell material	增强阻燃PBT Reinforced Flame Retardant PBT		
环境温度 Ambient temperature	-40°C~+85°C		
熔断器或断路器(A) Fuse or circuit breaker(A)	40A		
联线规格 Wire Specifications	相线/零线 Phase/Zero line	2.5~35mm ²	
	地线 Wire	4.0~35mm ²	
	信号线 The signal line	1.5mm ²	

外形及安装尺寸 Outline & installation size

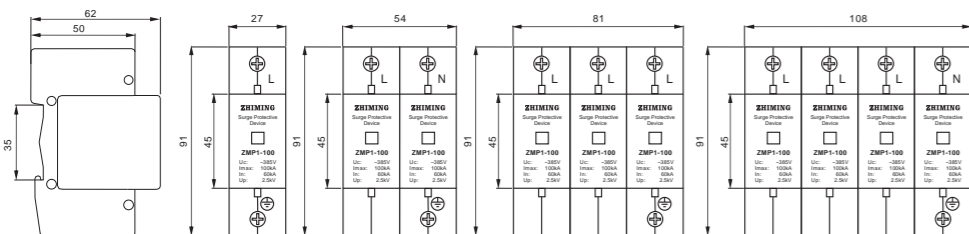

适用范围 Application

ZMP1-100电涌保护器(以下简称SPD)适用于交流50/60Hz、400V及以下的IT、TT、TN-C、TN-S、TN-C-S, 等供电系统, 对间接雷电和直接雷电影响或其它瞬时过电压的电涌进行保护。

ZMP1-100 series surge protective device (hereinafter called SPD) is suitable for the IT, TT, TN-C, TN-S, TN-C-S and etc power supply system of AC 50/60Hz, rated voltage 400V and below, to protect from direct and indirect lightning impulse and other transient over voltage.

型号及其含义 Code and implication

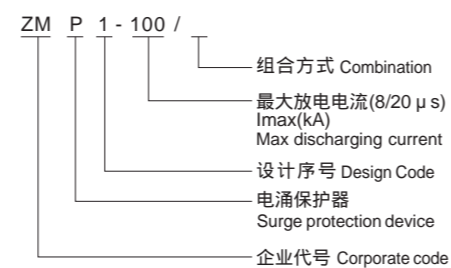

安装 Installation

- 安装在LPZ1 或LPZ2区与LPZ3 区交界处, 采用35mm的标准导轨安装, 连接铜质多股软线为2.5~35mm²。
- 通常安装在进线低压主配电柜处。
- 接地线应采用4mm²以上的双色导线, 长度不得超过500mm。
- 为了防止电涌保护器失效后影响电网正常运行, 联于L线保护器应该串联一个熔断器或断路器(注: 依据标称电涌选择)。

- To be mounted between LPZ1 or LPZ2 zone and LPZ3 zone, adopts 35mm standard mounting rail. The cross sectional area of multi-strand soft copper conductor: 2.5~35 mm².
- Generally it shall be mounted in the incoming side of main distribution panel or box.
- Earthing wire shall be of 4mm² dual color conductor, its length not more than 500mm.
- In order to eliminate the influence on normal service of power network due SPD is invalid, it shall add fuse or breaker to be series connected in L line. (NB: selected according to standard current In)

ZMP4

系列浪涌保护器

Series surge protection device



产品特点 Product Features

- 插拔式的电涌保护器
- 可视窗口颜色表示保护器工作状态:绿色(正常)红色(故障)
- 热熔过流双重保护
- 配置遥信接口, 能实现远程控制
- Plug in/out style surge protective device.
- The color of visible window shows operating status.
- Double protection of over-heat and over-current.
- Have the accessory of remote signaling interface, could be remote control

主要技术参数 Main technical data

参数 Technical Parameters	ZMP4				
额定工作电压 Rated Operating Voltage Un (V~)	380V 220V				
最大持续工作电压 Maximum Continuous Operating Voltage Uc (V~)	275V/385V/420V/440V				
电压保护水平 Voltage Protection Level Up (V~) kV	1.2	1.5	1.8	2.0	2.4
最大放电电流 Maximum Discharge Current Imax (8/20 μs)	5	10	20	30	40
标称放电电流 Nominal Discharge Current In (8/20 μs)	10	20	40	60	80
响应时间 Response Time ns	<25				
工作环境 Operating Environment	-40 ~+85				
相对湿度 Relative Humidity (25)	95%				
安装 Installation	标准导轨 Standard Rail 35mm				
外壳材料 Material of Outer Covering	玻璃纤维增强塑料 Fiber glass reinforced plastic				

外形及安装尺寸 Outline & installation size

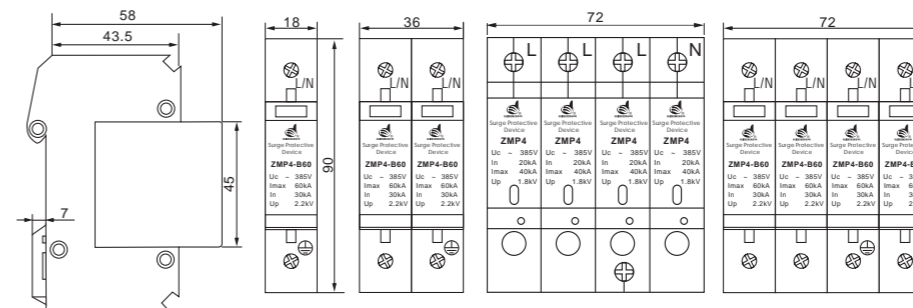

适用范围 Application

ZMP4 系列电涌保护器适用于交流50/60Hz, 380V及以下的TT、TN-C、TN-S、IT等供电系统, 对间接雷电或直接雷电影响或其它瞬间过电压进行保护。

ZMP4 series surge protective device (SPD) is suitable for TN-S, TN-C-S, TT, IT etc. Power supply system of AC 50/60Hz, 380V, which protects the electric device not shocked by the thunder or surge over-voltage.

型号及其含义 Code and implication

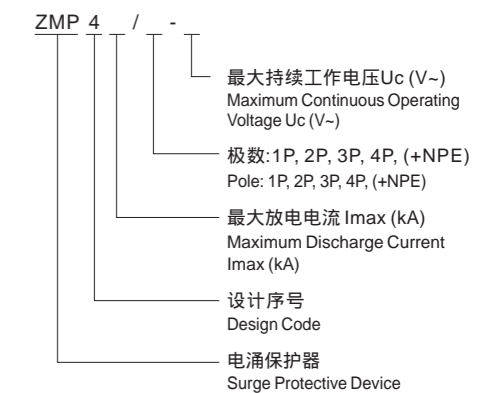

产品应用和安装位置 Application Scope and Installation Position

- ZMP4系列产品, 安装在LPZ0A区或LPZ0B区与LPZ1区交界面处。适用于住户配电箱、计算机设备、信息设备、电子设备及控制设备前或最近的电源箱内。
- 产品设计和订货须知: 用户在产品设计和订货时, 应详细标明产品型号、数量。例如: ZMP4-B60/4P-385, 8台。

- ZMP4 series surge protective device is applicable for B, C grade surge protection, installed on the joint of LPZ0A zone or LPZ0B and LPZ1 zone, which protects the electric network not shocked by the thunder and lightning. These series usually installed in household distribution boards, computer equipment, information equipment, electronic equipment and in the socket box in front of control equipment or near the control equipment.
- Notice: When you order our goods, please write the model and quantity carefully. For example: ZMP4-B60/4P-385, 8 pieces.

ZMP1-100/120/150

电源电涌保护器

Series surge protection device



主要结构与工作原理 Operation Elements

- 响应速度快，小于25纳秒。 Fast response time: less than 25ns
- 限制电压低。 Low limited voltage
- 通流容量大。 Large current carrying capacity
- 正常白色、失效红色。 Normal state: white color, invalid state: red color
- 可采用凯文接线方式。 Kelvin wiring mode available.

主要技术参数 Main technical data

型号规格 Model and specification	ZMP1-100			ZMP1-120			ZMP1-150				
最大持续工作电压Uc(VAC) Maxi continuous operating voltage	420V	385V	275V	420V	385V	320V	275V	420V	385V	320V	275V
电压保护水平Up(kV) Voltage protective level	2.6kV	2.5kV	1.8kV	2.7kV	2.6kV	2.2kV	2.0kV	3.2kV	3.0kV	2.5kV	2kV
标称放电电流(8/20 μs)In(kA) Nominal discharging current	60			80			100				
最大放电电流(8/20 μs)Imax(kA) Maxi discharging current	100			120			150				
响应时间ns Response time	<25										
防护等级 Protection grade	IP20										
失效指示 Indication of invalidation	老化失效：白色正常，红色失效 Aging invalidation: white: Normal, red: invalidation										
用途 Application	进线一级保护 Primary protection for in line										
遥信功能 Remote signal Function	可另配货 Can also picking										
备注 Remarks	其它最大持续工作电压UC175、440、690V可定做 Other maxi continuous operating voltage UC175,440,690V Can be customized										

外形及安装尺寸 Outline & installation size

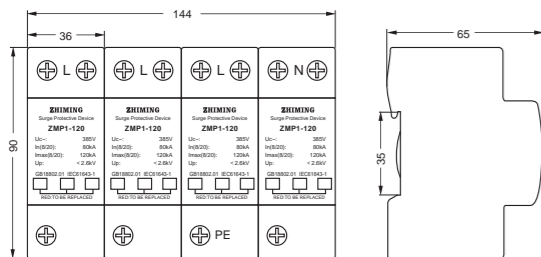

遥信触点 The Contact

保护器可以增加遥信功能，遥信触点有常开常闭触点，如果保护器的模块或者多个模块失效，触点将闭合送出故障信息。
SPD can provide the NO contact for remote communication, if one or more modules of SPD is invalid, the NO and NC contact will be closed and send fault information.

适用范围 Application

ZMP1系列电涌保护器(以下简称SPD)适用于TT、TN-C、IT等供电系统三相电源的B级电涌保护。该产品采用一体的设计，其保护模式有L-PE/N-PE、L-N/N-PE两种。具有通流容量大、残压低等特点；保护器本体具有热脱离告警功能，可根据用户要求增加遥信触点。

ZMP1 series surge protective device (hereinafter called SPD) is suitable for the IT, TT, TN-S for three-phase power distribution system. The SPD mode L-PE/N-PE, L-N/N-PE two. Having a large current capacity, low residual voltage characteristics; The SPD main body heat from the light alarm function, can according to user requirements increase remote contact.

型号及其含义 Code and implication

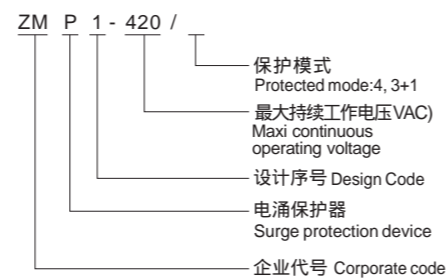

安装 Installation

- B级雷电流SPD保护，用于雷击时等电位连接。
- 通常安装在进线低压主配电柜处一架空进线。
- 保护器采用标准35mm轨道。
- 订货时须指明SPD的型号、规格和数量。
- 保护采用10~35mm²的铜质导线连接，接地线应采用16mm²以上的双色铜质多股软导线。
- Category B surge protective device (SPD), used in the connection between equal potential electrodes while thunder occur.
- Generally to be installed in low voltage main incoming distribution panel, overhead incoming.
- To adopt 35mm standard mounting rail for SPD mounting.
- When to place an order, please indicate the model, specification and quantity of SPD.
- It shall adopt 10~35mm² copper conductor to be connected with SPD, earthing wire shall be dual color multi-strand soft copper conductor more than 16mm²

ZMP-I15

一级电涌保护器

Series surge protection device



型号及其含义 Code and implication

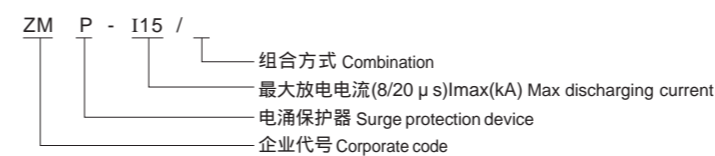

主要技术参数 Main technical data

型号规格 Model and specification	ZMP-I15
适用电源Power	220/385V ~50Hz
最大持续工作电压Uc(VAC) Maxi continuous operating voltage	275/385V
绝缘电阻Rins Insulation resistance Rins	>100 Mohm
冲击电流 The impact of current (10/350)Iimp	电流峰值The peak current of Ipeak 15KA 电荷量The amount of charge 7.5AS 能量Energy W/R 56.25KJ/Q
标称放电电流(8/20 μs)In(kA)Nominal discharging current	15KA
最大放电电流(8/20 μs)Imax(kA)Maxi discharging current	100KA
电压保护水平Up(kV) Voltage protective level	1.8KV
响应时间ns Response time	100ns
工作温度 Working temperature	-40°C~+80°C
外壳材料 Shell Material	阻燃尼龙 Flame retardant nylon
防护等级 Protection grade	IP20
配前置熔断器 With the pre fuse	100A
连接导体截面积 Cross - sectional area of conductor	6~35mm ²

外形及安装尺寸 Outline & installation size

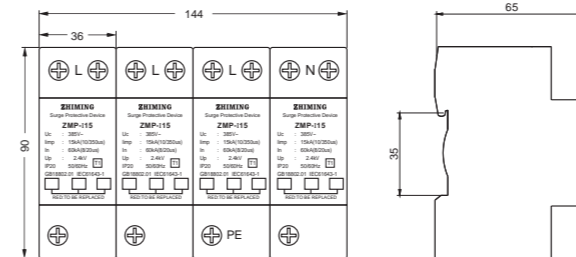

适用范围 Application

ZMP-I15系列限压型电涌保护器(属一级防雷器，10/350 μs波形)依据IEC和GB标准设计。应用于雷击风险较高地区的设备系统的电源一级电涌保护。可防范直击雷在内的各种电涌电流，通过不同数量的组合可适用于单相、三相供电线路，模块化设计，标准35mm导轨式安装方式，安装于建筑物总配电箱(箱)、室外配电箱(箱)，具备很高的雷电流泄放能力，无续流，单模块最大冲击电流(10/35 μs)分别可达Iimp=15kA, Iimp=25kA, Iimp=35kA, Iimp=50kA最大放电电流(8/20 μs)可分别达到Imax=100kA, Imax=150kA, Imax=160kA, Imax=200kA

ZMP-I15 series of pressure limiting type surge protective device(a Lightning arrester, 10/35 μs waveform) 3 according to IEC and GB standards. Equipment system used in high risk area of the power supply of the first Primary surge protection. Can prevent lightning strike, all kinds of surge current, pass A combination of different number of suitable to single-phase, three-phase power supply line, die-Modular design, standard 35mm rail mounted, installed in the building the total power distribution cabinet (box), outdoor distribution cabinet (box), with lightning current high the discharge capacity, free wheeling, single module maximum impulse current (10/35 μs) brancDon't reach Iimp=15kA, Iimp=25kA, Iimp=35kA, Iimp=50kA Maximum discharge current (8/20 μs) can reach Imax=100kA, Imax=150kA, Imax=160kA, Imax=200kA.

正常工作条件 Normal operating conditions

- 环境温度：-40°C~+80°C
- 海拔不超过2000m
- 相对湿度不大于90%(25°C)
- 安装方式与TH35mm宽导轨配套
- 适用的接地系统“IT, TT, TS, TN-N-S”
- 与垂直面的倾斜度不超过50°
- 无冲击振动或无摇动的地方
- 无爆炸危险的介质中，且介质中无中产腐蚀性金属和破坏绝缘的气体与尘埃。
- Ambient air temperature: -40°C~+80°C
- Altitude: not higher than 2000m
- Relative humidity: 90%(25°C)
- Installation: TH35-7.5 DIN rail
- For grounding system: IT, TT, TS, TN-N-S
- Vertical inclination 50°
- The ambient air is not significantly polluted by dust, smoke, corrosive and/or flammable gases, vapours or salt.

ZMP-I25

一级电涌保护器

Series surge protection device



型号及其含义 Code and implication

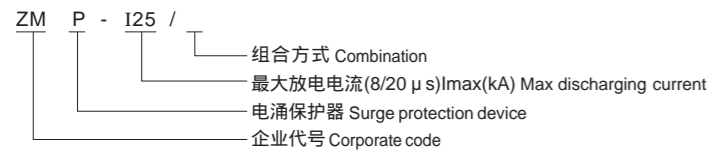

主要技术参数 Main technical data

型号规格 Model and specification	ZMP-I25	
适用电源 Power	220/385V ~50Hz	
最大持续工作电压Uc(VAC) Maxi continuous operating voltage	275/385V	
绝缘电阻Rins Insulation resistance Rins	>100 Mohm	
冲击电流 The impact of current (10/350)Iimp	电流峰值 The peak current of Ipeak	25KA
	电荷量 The amount of charge	12.5AS
	能量 Energy W/R	156.25KJ/Q
标称放电电流(8/20 μs)In(kA)Nominal discharging current	25KA	
最大放电电流(8/20 μs)Imax(kA)Maxi discharging current	150KA	
电压保护水平Up(kV) Voltage protective level	1.8KV	
响应时间ns Response time	100ns	
工作温度 Working temperature	-40°C~+80°C	
外壳材料 Shell Material	阻燃尼龙 Flame retardant nylon	
防护等级 Protection grade	IP20	
配前置熔断器With the pre fuse	125A	
连接导体截面积 Cross - sectional area of conductor	6~35mm ²	

外形及安装尺寸 Outline & installation size

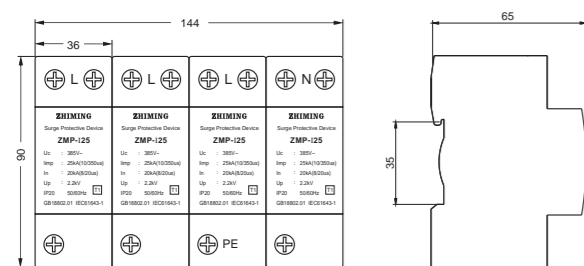

适用范围 Application

ZMP-I25系列限压型电涌保护器(属一级防雷器, 10/350 μs波形)依据IEC和GB标准设计。应用于雷击风险较高地区的设备系统的电源第一级电涌保护。可防范直击雷在内的各种电涌电流, 通过不同数量的组合可适用于单相、三相供电线路, 模块化设计, 标准35mm导轨式安装方式, 安装于建筑物总配电箱(箱)、室外配电箱(箱), 具备很高的雷电流泄放能力, 无续流, 单模块最大冲击电流(10/35 μs)分别可达Iimp=15kA, Iimp=25kA, Iimp=35kA, Iimp=50kA最大放电电流(8/20 μs)可分别达到Imax=100kA, Imax=150kA, Imax=160kA, Imax=200kA

ZMP-I25 series of pressure limiting type surge protective device(a Lighting arrester, 10/35 μs waveform) 3 according to IEC and GB standards. Equipment system used in high risk area of the power supply of the first Primary surge protection. Can prevent lighting strike, all kinds of surge current, pass A combination of different number of suitable to single-phase, three-phase power supply line, die-Modular design, standard 35mm rail mounted, installed in the building the total power distribution cabinet (box), outdoor distribution cabinet (box), with lighting current high the discharge capacity, free wheeling, single module maximum impulse current (10/350 μs) brancDon't reach Iimp=15kA, Iimp=25kA, Iimp=35kA, Iimp=50kA Maximum discharge current (8/20 μs) can reach Imax=100kA, Imax=150kA, Imax=160kA, Imax=200kA.

正常工作条件 Normal operating conditions

- 环境温度: -40°C~+80°C
- 海拔不超过2000m
- 相对湿度不大于90%(25°C)
- 安装方式与TH35mm宽导轨配用
- 适用的接地系统“IT, TT, TS, TN-N-S”
- 与垂直面的倾斜度不超过50°
- 无冲击振动或无摇动的地方
- 无爆炸危险的介质中, 且介质中无中产腐蚀性金属和破坏绝缘的气体与尘埃。
- Ambient air temperature: -40°C~+80°C
- Altitude: not higher than 2000m
- Relative humidity: 90%(25°C)
- Installation: TH35-7.5 DIN rail
- For grounding system: IT, TT, TS, TN-N-S
- Vertical inclination 50°
- The ambient air is not significantly polluted by dust, smoke, corrosive and/or flammable gases, vapours or salt.

ZMP-I50

一级电涌保护器

Series surge protection device



型号及其含义 Code and implication

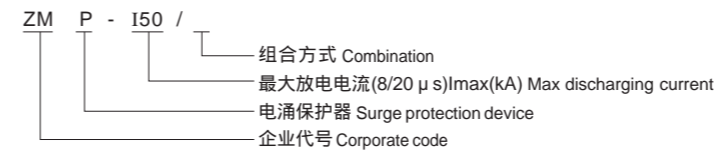

主要技术参数 Main technical data

型号规格 Model and specification	ZMP-I50	
适用电源 Power	220/385V ~50Hz	
最大持续工作电压Uc(VAC) Maxi continuous operating voltage	275/385V	
绝缘电阻Rins Insulation resistance Rins	>100 Mohm	
冲击电流 The impact of current (10/350)Iimp	电流峰值 The peak current of Ipeak	50KA
	电荷量 The amount of charge	25AS
	能量 Energy W/R	625KJ/Q
标称放电电流(8/20 μs)In(kA)Nominal discharging current	25KA/50KA	
最大放电电流(8/20 μs)Imax(kA)Maxi discharging current	200KA	
电压保护水平Up(kV) Voltage protective level	2.2KV	
响应时间ns Response time	100ns	
工作温度 Working temperature	-40°C~+80°C	
外壳材料 Shell Material	阻燃尼龙 Flame retardant nylon	
防护等级 Protection grade	IP20	
配前置熔断器With the pre fuse	125A	
连接导体截面积 Cross - sectional area of conductor	6~35mm ²	

外形及安装尺寸 Outline & installation size

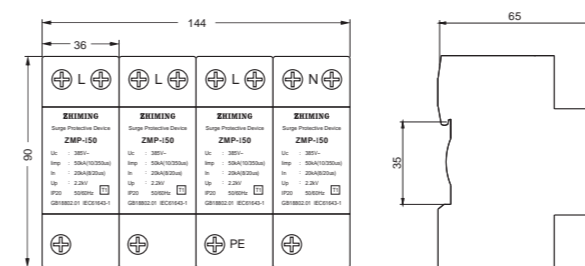

适用范围 Application

ZMP-I50系列限压型电涌保护器(属一级防雷器, 10/350 μs波形)依据IEC和GB标准设计。应用于雷击风险较高地区的设备系统的电源第一级电涌保护。可防范直击雷在内的各种电涌电流, 通过不同数量的组合可适用于单相、三相供电线路, 模块化设计, 标准35mm导轨式安装方式, 安装于建筑物总配电箱(箱)、室外配电箱(箱), 具备很高的雷电流泄放能力, 无续流, 单模块最大冲击电流(10/35 μs)分别可达Iimp=15kA, Iimp=25kA, Iimp=35kA, Iimp=50kA最大放电电流(8/20 μs)可分别达到Imax=100kA, Imax=150kA, Imax=160kA, Imax=200kA

ZMP-I50 series of pressure limiting type surge protective device(a Lighting arrester, 10/35 μs waveform) 3 according to IEC and GB standards. Equipment system used in high risk area of the power supply of the first Primary surge protection. Can prevent lighting strike, all kinds of surge current, pass A combination of different number of suitable to single-phase, three-phase power supply line, die-Modular design, standard 35mm rail mounted, installed in the building the total power distribution cabinet (box), outdoor distribution cabinet (box), with lighting current high the discharge capacity, free wheeling, single module maximum impulse current (10/350 μs) brancDon't reach Iimp=15kA, Iimp=25kA, Iimp=35kA, Iimp=50kA Maximum discharge current (8/20 μs) can reach Imax=100kA, Imax=150kA, Imax=160kA, Imax=200kA.

正常工作条件 Normal operating conditions

- 环境温度: -40°C~+80°C
- 海拔不超过2000m
- 相对湿度不大于90%(25°C)
- 安装方式与TH35mm宽导轨配用
- 适用的接地系统“IT, TT, TS, TN-N-S”
- 与垂直面的倾斜度不超过50°
- 无冲击振动或无摇动的地方
- 无爆炸危险的介质中, 且介质中无中产腐蚀性金属和破坏绝缘的气体与尘埃。
- Ambient air temperature: -40°C~+80°C
- Altitude: not higher than 2000m
- Relative humidity: 90%(25°C)
- Installation: TH35-7.5 DIN rail
- For grounding system: IT, TT, TS, TN-N-S
- Vertical inclination 50°
- The ambient air is not significantly polluted by dust, smoke, corrosive and/or flammable gases, vapours or salt.

ZM-PV

光伏电涌保护器

Series PV surge protection device



产品特点 Features

- 插拔式的电涌保护器
- 可视窗口颜色表示保护器工作状态，绿色(正常)，红色(故障)。
- 热熔过流双重保护
- 配置通信接口，能实现远程控制。
- Surge protective device, plug
- The visual windows color said protector working state; green(normal), red(fault)
- Hot melt flow double protection.
- The configuration remote communication interface, can realize remote control.

主要技术参数 Main technical data

名称 Name	500V 直流电源防雷模块 DC Power supply lightning protection module	800V 直流电源防雷模块 DC Power supply lightning protection module	1000V 直流电源防雷模块 DC Power supply lightning protection module
产品型号 Product model	ZM-PV-500	ZM-PV-800	ZM-PV-1000
标称通流容量 Normal capacity the flow In(kA 8/20 μs)		20	
最大通流容量 Maximum flow capacity I _{max} (kA 8/20 μs)		40	
保护水平 Protection level(kV)	2.5	3.0	4.0
响应时间 Response time(ns)	25	25	25
额定工作电压 Rated voltage(VDC)	500	800	1000
持续工作电压 Continue to work voltage(VDC)	550	880	1100
漏电流 Leakage current 0.75U 1mA(μA)		20	
工作温度 Working temperature(°C)		-40°C~+85°C	

外形及安装尺寸 Outline & installation size

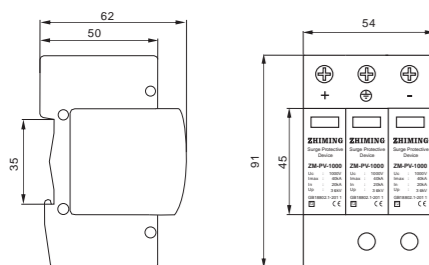

适用范围 Application

ZM-PV系列电涌保护器适用于新能源风力太阳能发电系统，工作电压500V、800V、1000V。安装位置在直流电路总电源系统中，对间接雷电流、直流雷电流或其它瞬时过电压进行保护。

ZM-PV series surge protective device is suitable for new energy wind power system, working voltage of 500V, 800V, 1000V Installation position in the total power supply DC circuit systems, direct, indirect lightning current of lightning current or other transient over-voltage protection.

型号及其含义 Code and implication

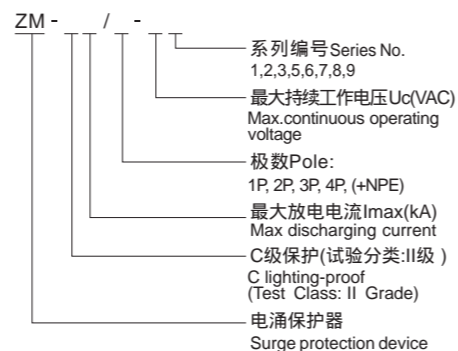

安装 Installation

- 安装前必须切断电源，严禁带电操作。
- 建议在防雷模块前端串联熔断器或断路器。
- 安装时请根据安装示意图所示连接，其中+为正极线，-为负极线，PE为地线，切勿错接。安装完成后，合上断路(熔断器)开关，检查工作状态是否正常。
- 安装完毕后，将模块插到到位，检查防协模块是否正常工作。
- 防雷模块在使用期间，应定期检测并查看故障显示窗口状态，当故障显示窗呈红色或遥信端子输出报警信号时，表示防雷模块发生故障，应及时维修或更换。
- 并联式电源防雷模块应并联安装，连接线要求牢固可靠，且要求短、粗、直。
- The power must be cut off before installation, strictly charged operation.
- Series fuse or breaker in front of lightning protection module.
- Please install according to the installation diagram shown in connection, where in+positive line, as the negative wire, PE wire, not the wrong connection. After the installation is complete, close the circuit breaker(fuse) switch, check whether the normal work state.
- After the installation of the module is inserted in place, check the anti co module is working.
- Lighting protection module during use, should be regularly tested and view the fault display window state, when a fault display window is terminal output red or remote alarm signal, said lightning protection module failure, should be timely repair or replacement.
- Parallel type power supply lightning protection module should be installed in parallel connection line, firm and reliable, and the requirement of short, coarse, straight.

SZM1

系列塑壳式断路器

Series Molded Case Circuit Breaker



适用范围 Application

SZM1系列塑料外壳式断路器(以下简称断路器)主要用于交流50Hz(或60Hz)，额定绝缘电压690V，额定工作电压690V及以下，额定电流1250A及以下的配电网中作为分配电能和保护线路及电源设备的过载、欠电压和短路保护，400A壳架等级以下的断路器也可作为电动机的过载、欠电压和短路保护。在正常情况下可作为线路的不频繁转换和电动机的不频繁启动之用。

产品符合：IEC 60947-2、GB 14048.2标准。

SZM1 series molded case circuit breaker (hereinafter referred to as circuit breaker) is suitable for distributing network of AC 50Hz (or 60Hz), rated insulation voltage 690V, rated working voltage 690V or below and rated current 1250A or below. It can be used to distribute electric energy and protect the circuit and electric equipment against overload, short circuit and under voltage, furthermore, the circuit breakers of frame size 400A below also can protect the motor against overload, under voltage and short circuit. Under normal condition, the circuit breaker also can be used to switch the circuit and start the motor infrequently. The products are in conformity with such standards as IEC 60947-2 and GB 14048.2.

过电流特性曲线 Characteristic curve

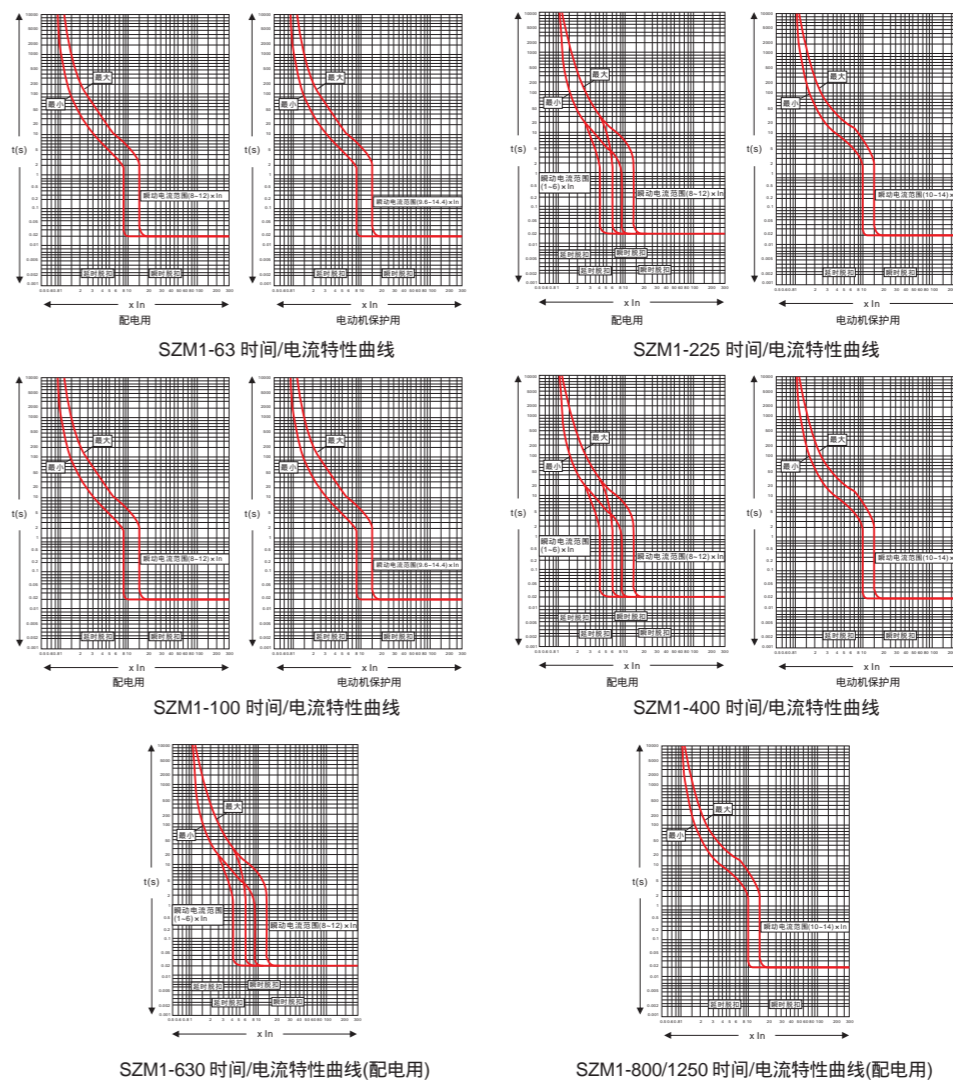

SZM1

系列塑壳式断路器

Series Molded Case Circuit Breaker



主要技术参数 Main Technical data

断路器型号 Type of circuit breaker	SZM1-63			SZM1-125			SZM1-250			SZM1-400			SZM1-630			SZM1-800			SZM1-1250	SZM1-1600						
极数 Pole	3	4		3	2	4	3	2	4	3	4		3	4		3	4		3	4	3					
额定电流 In A Rated current	6,10,16,20, 32,40,50,60	10,16,20,32,40, 50,63,80,100			100,125,160 180,200,255			200,225,250 315,350,400			400,500 630			630,700 800			800,1000 1250,1600									
额定绝缘电压 Ui V Rated insulation Voltage	690			800																						
额定冲击耐受电压 Uimp V Rated impulse withstand voltage	6000			8000																						
额定工作电压 Ue V Rated working Voltage	AC400/690																									
分断能力级别 Breaking capacity class	L	M	L	M	H		L	M	H		L	M	H		L	M	H		L	M	H					
极限短路分断能力 Icu kA Ultimate short-circuit breaking capability O-t-CO	400V	25	50	35	50	85	50	35	65	85	50	50	70	100	50	50	65	100	65	50	70	100	50	80		
	690V				20	20		20	20					20						20						
运行短路分断能力 Ics kA Service short-circuit breaking capability O-t-CO-t-CO	400V	18	30	22	35	43	35	22	42	43	30	35	40	50	30	35	50	65	42	35	37.5	50	30	50		
	690V				10	10		10	10					10						10						
飞弧距离 mm Flashover distance	50										100															
操作循环 次数/次 Operation cycle /Time	每小时 Per hour		120			60			60			20														
	通电流 Power on		4000			3000			1500			1000			500											
	不通电 Power off		6000			7000			6500			4000			2500											
功率损耗 W Power loss	固定式 Fixing type		20	25	33	35	40	40	26	63	55	60	60	40	80	80	40	120	130	150	150	200	125	135	180	240
	插入式 Insertion type		25	30		40	50	50			65	75	75			100	110		180	200	200		170	190		300

外形及安装尺寸 Outline & installation size

1、固定式板前、板后接线的外形及安装尺寸 Outline & installation size of fixing type fore and rear connections

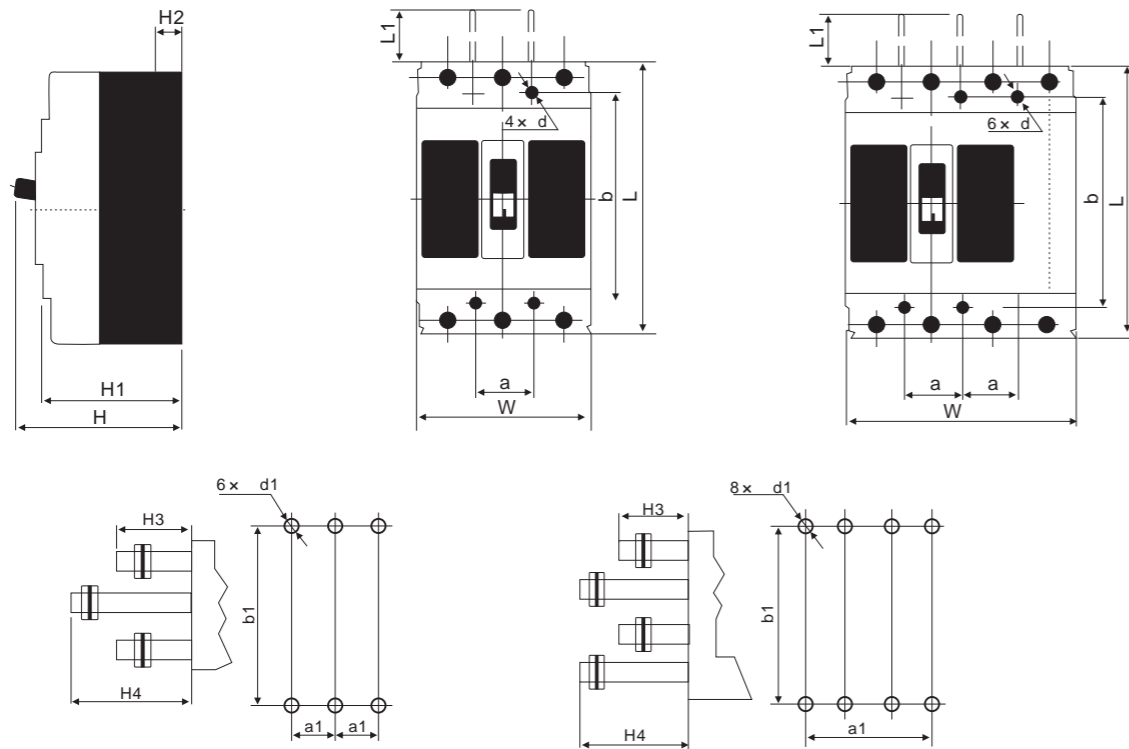

三极的板后接线尺寸
3-pole rear connection size

四极的板后安装尺寸
4-pole rear connection size

固定式板前、板后接线的外形及安装尺寸

Outline & installation size of fixing type fore and rear connections

型号 Type	极数 Pole	外形尺寸 Outline size						安装尺寸 installation size			板后接线尺寸 connection size				
		高L	L1	宽W	H	H1	H2	a	b	孔径 d	a1	b1	d1	H3	H4
SZM1-63L	3	135	21	76	89.5	74	21	25	117	3.5	25	117	18	52	75
SZM1-63M					99	82	28								
SZM1-63L	4			103											
SZM1-100L	3	150	51	90	87	68	25	30	129	4.5	30	132	22	65	100
SZM1-100M					103.5	84	24								
SZM1-100H	4			122											
SZM1-100															
SZM1-225L	3	165	64	107	110	87	25	35	126	4.5	35	144	24	70	110
SZM1-225M					126	104	24.5								
SZM1-225H	4			142											
SZM1-225															
SZM1-400	3	257	105	150	146	106	36.5	44	194	6.5	44	225	32	70	120
	4			200											
SZM1-630	3	270	118	182	160	112	41	58	200	7	58	234	40	70	120
	4			240											
SZM1-800	3	280	102	210	146	108	34.5	70	243	7	70	243	48	75	125
	4			280											
SZM1-1250	3	406	104	210	190	140.5	58.5	70	375	10					

断路器脱扣方式及附件代号 Tripping modes and accessory code

附件名称 Accessory name	不加附件 Without accessories	报警触点 Alarm contact	分励脱扣器 Shunt release	辅助触点 Auxiliary contact	欠压脱扣器 Under-voltage release	分励脱扣器及辅助触点 Shunt release and Auxiliary contact	分励脱扣器及欠压脱扣器 Shunt release, Under-voltage release	二组辅助触点 Two pairs of Auxiliary contacts	辅助触点及欠压脱扣器 Auxiliary contact, Under-voltage release	辅助触点及报警触点 Auxiliary contact, alarm contact	分励脱扣器及报警触点 Shunt release, alarm contact	欠压脱扣器及报警触点 Under-voltage release, alarm contact	分励脱扣器辅助触点及报警触点 Shunt release, Auxiliary contact, alarm contact	分励脱扣器欠压脱扣器报警触点 Shunt release, Under-voltage release, alarm contact	二组辅助触点 报警触点 Shunt release, Auxiliary contact, alarm contact	欠压脱扣器报警触点 报警触点 Under-voltage release, Auxiliary contact, alarm contact
代号 Code																
脱扣方式 Tripping mode																
电磁瞬时脱扣器 Electromagnetic instantaneous release	200	208	210	220	230	240	250	260	270	218	228	238	248	258	268	278
复式脱扣器 Combined release	300	308	310	320	330	340	350	360	370	318	328	338	348	358	368	378

注：SZM1系列三极开关的手操机构、电操机构、机械联锁装置均通用于四级开关。

SZM1E

系列智能型塑壳式断路器

Series Molded Case Electronic Circuit Breaker



型号及其含义 Code and implication

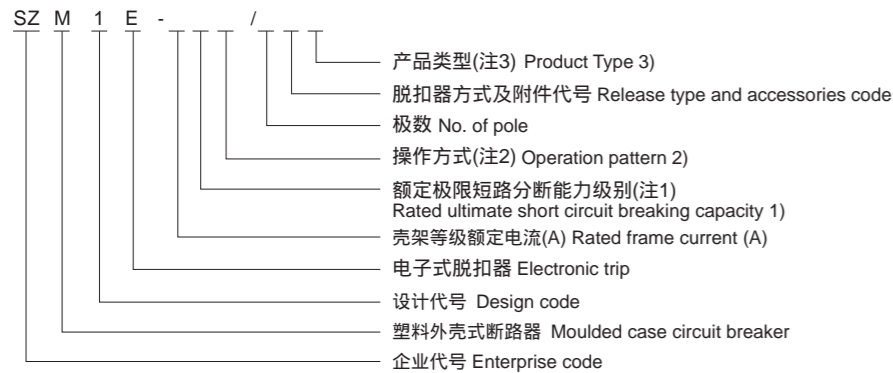

注:

- 按额定极限短路分断能力的高低分为M型(较高分断型)、H型(高分断型)。
- 手柄直接操作无代号;电动操作用P表示;转动手柄用Z表示。
- 基本型无代号,智能通讯型用Z表示,编程通讯型用B表示,消防型用X表示,液晶显示用L表示。

Classification:

- According to breaking capacity of breaker: standard type(L), Higher type (M), Higher type (H).
- According to operation mode: Direct operation with handle, P-Motor driven operation, Z-Operation with rotary handle.
- N/A: Normal type, Z: Intelligent communication type, B: Programming communication type, X: Fire-type, L: LCD

正常使用条件 Normal service conditions

- 海拔: 2000m
- 环境温度: $-5^{\circ}\text{C} \sim +40^{\circ}\text{C}$
- 能耐受潮湿空气的影响,能耐受盐雾、油雾的影响
- 污染等级为3级
- 最大倾斜度为 22.5°
- 在无爆炸危险的介质中,且介质无足以腐蚀金属和破坏绝缘的气体与导电尘埃的地方,在没有雨雪侵袭的地方
- 安装类别
- Altitude 2000m.
- Ambient air temperature: $-5^{\circ}\text{C} \sim +40^{\circ}\text{C}$
- Be able to bear the influence of moisture in the air or salt fog and oil fog or mould or nuclear industry environment.
- Pollution protection: 3 grade.
- The gradient $\pm 22.5^{\circ}$
- The ambient air is not significantly polluted by dust, smoke, corrosive and/or flammable gases, vapours or salt.
- Installing categories: III

高海拔降容表 High altitude derating

海拔(m) Altitude	2000	3000	4000	5000
工频耐压(V) Power frequency withstand voltage	3000	2500	2000	1800
工作电流修正系数 Operating current correction factor	1	0.94	0.88	0.83
短路分断能力修正系数 Short - circuit breaking capacity correction factor	1	0.83	0.71	0.63

适用范围 Application

- SZM1E系列智能型塑料外壳式断路器(以下简称断路器),适用于交流50Hz(或60Hz),其额定绝缘电压为800V,额定工作电压690V及以下,额定工作电流至800A的电路中作不频繁转换及电动机不频繁启动之用。断路器具有过载长延时反时限、短路短延时反时限、短路短延时定时限、短路瞬时和欠压保护功能以及剩余电流保护(可选)缺相保护功能(可选),能保护线路和电源设备不受损坏,断路器保护特性齐全、精确,能提高供电可靠性,避免不必要的停电,其中“Z、B”型控制带有通讯接口,可进行“四遥”,以满足控制中心和自动化系统的要求。
- 断路器按照其额定极限短路分断能力的高低,分为M型(较高分断型)、H型(高分断型)二种。该断路器具有体积小、分断能力高、飞弧短、抗振动等特点。

SZM1E series Molded Case Electronic Circuit Breaker (hereafter referred to as simply breakers) are one of the new type breakers which have been developed by the company using international advanced design and manufacturing technology. The rated insulation voltage of the breakers is 800V, suitable for turn-on or turn-off not frequently and starting a motor not frequently in the circuit of AC50Hz, rated working voltage 690V or below rated working current up to 800A. The breakers have overload, short-circuit and under voltage protection devices. so as to protect the circuit and the power equipment against damage. Short circuit short delay time definite time, short circuit instantaneous and undervoltage protection function and residual current protection (optional), phase failure protection function (optional), can short-circuit short delay time inverse time, Protection circuit and power equipment from damage, circuit breaker protection features complete, accurate, can improve the reliability of power supply, to avoid unnecessary power outages, including "Z, B" type control with communication interface can be "four remote" Meet the requirements of control centers and automation systems.

- The breakers according to the rated maximal value to short-circuit breaking ability (Icu), would be classified four kinds types C (basic type), L (typical type), M (second high breaking type) and H (high breaking type). The breakers are of the following characteristics: compact size, high breaking ability, short arc-over distance (some of the "0" arc-over distance) and shake proof. They also undergo the tests of nuclear industry conditions (1E grade) and ship conditions, and become the only product using in nuclear industry base among the same products made in the country, further more become the ideal products applied on land or ships.

主要技术参数 Main Technical data

型号 Type	SZM1E-125			SZM1E-250			SZM1E-400			SZM1E-630			SZM1E-800					
壳架等级额定电流Inm(A) Rated frame current	125			250			400			630			800					
额定电流In(A) Rated current	16,20,25,32	32,36,40,45,50,55,60,63	63,65,70,75,80,85,90,95,100	100,125,140,160,180,200,225,250			200,225,250,280,315,350,400			400,420,440,460,480,500,530,560,600,630			630,640,660,680,700,720,740,760,780,800					
额定工作电压Ue(V) Rated Working Voltage	AC400V																	
额定绝缘电压Ui(V) Rated insulation Voltage	AC800V																	
额定冲击耐受电压Uimp (V) Rated impulse withstand voltage	AC8000V																	
极数 Pole	3		4		3		4		3		4		3		4			
分断能力级别 Breaking capacity class	M		H		M		H		M		H		M		H			
额定极限短路分断能力Icu (kA) Rated ultimate short - circuit breaking capacity	50		85		50		85		85		100		85		100			
额定运行短路分断能力Ics (kA) Rated operating short - circuit breaking capacity	35		50		35		50		35		55		65		55			
额定短时耐受电流Icw(kA)/1s Rated short time withstand current							5			8			10					
使用类别 Use categories	A						A			B			B					
操作性能(次) Operating performance (times)	通电 ON			3000			3000			2000			1500			1500		
	不通电 OFF			7000			7000			4000			3000			3000		
飞弧距离(mm) Flashover distance	50						50						100					

外形及安装尺寸 Outline & installation size

固定式板前、板后接线的外形及安装尺寸

Outline & installation size of fixing type fore and rear connections

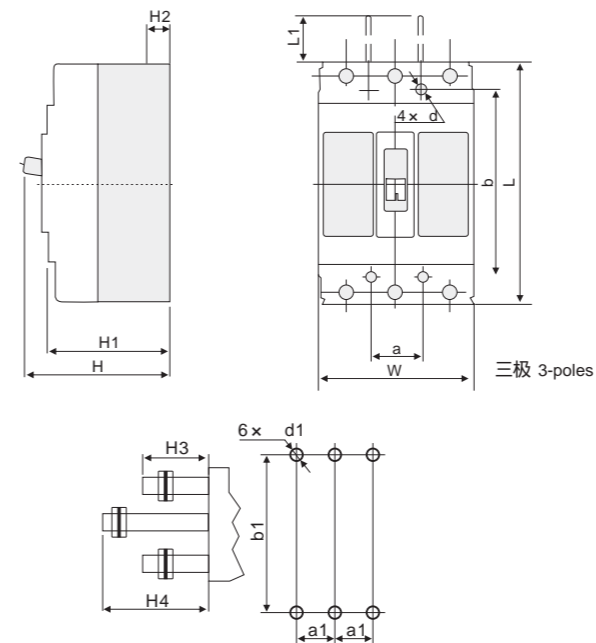

三极的板后接线尺寸 3-poles rear connection size

型号 Type	外形尺寸 Outline size						安装尺寸 installation size			板后接线尺寸 connection size				
	高L	L1	宽W	H	H1	H2	a	b	孔径 ϕd	a1	b1	d1	H3	H4
SZM1E-125/3300	150	51	92	110	92	26	30	129	4.5	30	132		65	100
SZM1E-125/4300			122											
SZM1E-250/3300	165	64	107	112	92	18	35	126	4.5	35	144		70	110
SZM1E-250/4300			142											
SZM1E-400/3300	257	105	150	146	108	36.5	44	194	6.5	44	225		70	120
SZM1E-400/4300			200											
SZM1E-800/3300	280	102	210	159	115	35	70	243	7	70	243		75	125
SZM1E-800/4300			280											

电子式脱扣器特性 Characteristics of electronic trip units

- 具有过载长延时反时限、短路短延时反时限、短路短延时定时限、短路瞬时动作等保护功能,可由用户自行设定组成所需的保护特性;中性线过电流保护电流、时间参数100%自动跟踪相线整定值。脱扣器特性见下图。
- Short-delay short-time inverse time, short-circuit short-time definite time limit, short-circuit instantaneous When the action protection, user-set by the composition of the required protection features; neutral line over-current Flow protection current, time parameter 100% automatic tracking phase line setting value. The characteristics of the release are shown below.

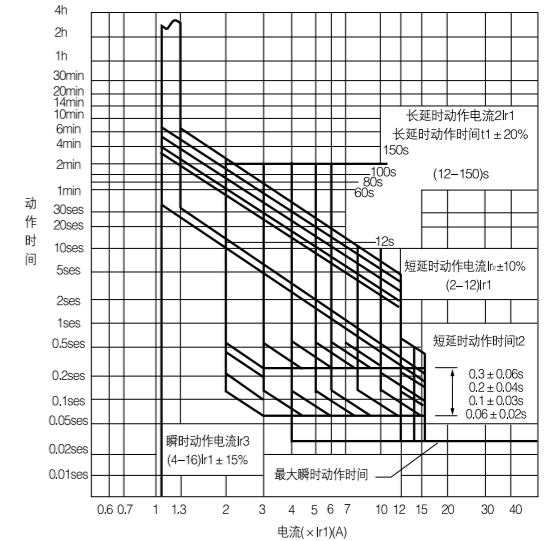

SZM1(NS)

系列塑壳式断路器 (电子式)

Series moulded case circuit breaker (electronic type)



型号及其含义 Code and implication

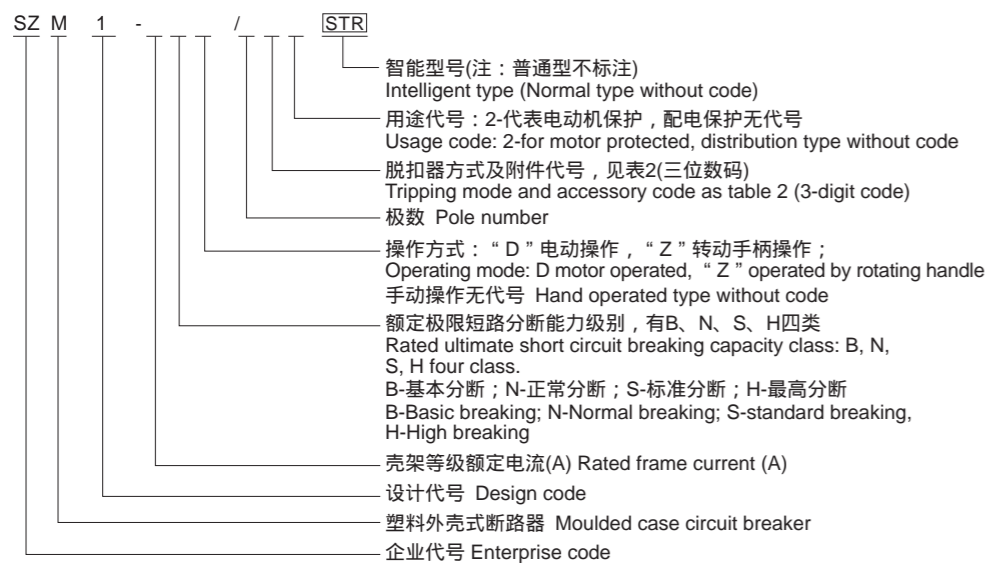

使用类别代号 Usage category

电路性质 Circuits	使用类别代号 Usage category	典型用途 Typical application
主电路 Main circuit	A AC-3	非选择性配电保护电动机保护(鼠笼型异步电动机的起动,运转中分断) Non-selective distribution protection, motor protection (start, run, break the squirrel-cage asynchronous motor)
辅助电路 Auxiliary circuit	AC-15 DC-13	控制大于72VA的交流电磁负载控制直流电磁铁负载 Control AC and DC electromagnetic loads more than 72VA

表Table 1

适用范围 Application

SZM1(NS)系列电子式塑料外壳式断路器适用于交流50Hz,额定电流从10A至630A,额定绝缘电压为690V(Inm=125A的为550V),额定工作电压660V(Inm=125A的为400V)及以下的电路中,在配电网中分配电能及作为线路和电气设备的过载,短路保护之用,在正常情况下断路器也可作为线路的不频繁转换之用,壳架等级电流400A及以下的断路器亦可作为保护电动机的不频繁启动之用。

执行标准:GB14048.2.

SZM1(NS) series electronic type moulded case circuit breaker is operating in the distribution line of AC50Hz, rated current from 10A to 630A, rated insulation voltage 690V (550V for Inm=125A), rated working voltage 660V (400V for Inm=125A) and below, to distribute electric energy and protect from overloading, short circuit fault. At normal status, the breaker is also used to not frequently transfer the circuit, the breaker with rated frame current not more than 400A can be used to start the motor not frequently.

Executed standard: GB14048.2

正常工作条件及安装条件

- 智能式断路器适用于下列工作环境:
- 安装地点的海拔高度不超过2000m
- 周围介质温度不高于40 和不低于-25
- 在无爆炸危险的介质中,且介质无足以腐蚀金属和破坏绝缘的气体及导电尘埃的地方
- 在无雨雪侵袭的地方
- 污染等级3
- 安装类别
- 断路器的安装方式,安装位置,及安装角度任意。

Normal working and mounting conditions

- The intelligent breaker suitable for working under following ambient conditions:
- Mounting altitude not exceed 2000m
- Ambient temperature not higher than 40 , not lower than -25 .
- Mounting site has no explosive medium, or gas able to corrode the metal or damage the insulation, has no conductive dust
- Rain and snow not accessible.
- Pollution grade: 3
- Mounting category III
- Mounting mode, mounting place, and mounting angle on random.

断路器脱扣方式及附件代号 Tripping modes and accessory code

表Table 2

附件名称 Accessory name	不加附件 without accessories	报警触点 Alarm contact	分励脱扣器 Shunt release	辅助触点 Auxiliary contact	欠压脱扣器 Under-voltage release	分励脱扣器及辅助触点 Shunt release and Auxiliary contact	分励脱扣器及欠压脱扣器 Shunt release, Under-voltage release	二组辅助触点 Two pairs of Auxiliary contacts	辅助触点和欠压脱扣器 Auxiliary contact, Under-voltage release	辅助触点和报警触点 Auxiliary contact, alarm contact	分励脱扣器及报警触点 Shunt release, alarm contact	欠压脱扣器及报警触点 Under-voltage release, alarm contact	辅助触点和报警触点 Auxiliary contact, alarm contact	分励脱扣器及报警触点 Shunt release, alarm contact	分励脱扣器及欠压脱扣器及报警触点 Shunt release, Under-voltage release, alarm contact	二组辅助触点和报警触点 Shunt release, Auxiliary contact, alarm contact	欠压脱扣器及报警触点 Under-voltage release, alarm contact	报警触点 Auxiliary contact
电磁瞬时脱扣器 Electromagnetic instantaneous release	200	208	210	220	230	240	250	260	270	218	228	238	248	258	268	278		
复式脱扣器 Combined release	300	308	310	320	330	340	350	360	370	318	328	338	348	358	368	378		

注:(1)复式脱扣器为热型反时限脱扣器串联电磁瞬时脱扣器;(2)268/368(二组辅助触点和报警触点)仅供Inm=630A的断路器。

Note: (1) combined release consists of thermal inverse time limit tripping device/release series connected with electromagnetic instantaneous tripping device/release. (2) 268/368 (two pairs of auxiliary contacts and alarm contacts) only for Inm=630A breaker

主要技术参数 Main technical data

型号 Type	极限短路分断能力kA Ultimate short circuit breaking capacity kA		运行短路分断能力kA Operating short circuit breaking capacity kA		壳架 电流A Frame current A	额定电流A Rated current A	操作次数及频率 Operation frequency and frequency			额定绝缘 电压Ui(V) Rated insulation voltage Ui(V)	额定工作 电压Ue(V) Rated working voltage Ue(V)	飞弧距离 mm Arcing distance mm
	400V	660V	400V	660V			有载 On-load	无载 No-load	次/h Times/h			
SZM1-125N	30	-	15	-	125	10,12.5,16,20,32,40,50,63,80,100,125,	1500	8500	120	500	400	30
SZM1-125H	50	-	25	-	125	10,12.5,16,20,32,40,50,63,80,100,125,	1500	8500	120	500	400	30
SZM1-160B	30	17	22	12.5	160	50, 63, 80, 100, 125, 160	1500	8500	120	690	400 600	30
SZM1-160N	35	20	25	15	160	50, 63, 80, 100, 125, 160	1500	8500	120	690	400 600	30
SZM1-160H	50	29	35	20	160	50, 63, 80, 100, 125, 160	1500	8500	120	690	400 600	30
SZM1-250N	35	20	26	15	250	125, 160, 200, 250	1000	7000	120	690	400 600	30
SZM1-250S	50	29	35	20	250	125, 160, 200, 250	1000	7000	120	690	400 600	30
SZM1-250H	65	37.5	48	28	250	125, 160, 200, 250	1000	7000	120	690	400 600	30
SZM1-400N	35	20	25	15	400	250, 315, 400	1000	4000	60	690	400 600	50
SZM1-400S	50	29	35	20	400	250, 315, 400	1000	4000	60	690	400 600	50
SZM1-400H	70	40	50	28	400	250, 315, 400	1000	4000	60	690	400 600	50
SZM1-630N	35	20	25	15	630	400, 500, 630	1000	4000	60	690	400 600	50
SZM1-630S	50	29	35	20	630	400, 500, 630	1000	4000	60	690	400 600	50
SZM1-630H	70	40	50	28	630	400, 500, 630	1000	4000	60	690	400 600	50

注:在每个操作循环期间,断路器保持接通的最长时间为2s。保护电动机用断路器在Un, 6In接通时,接通的最短时间为0.1s。

Note: in each operation cycle, breaker keep longest making time 2s, motor protected breaker has shortest making time 0.1s under Un and 6In.

外形及安装尺寸 Outline & installation size

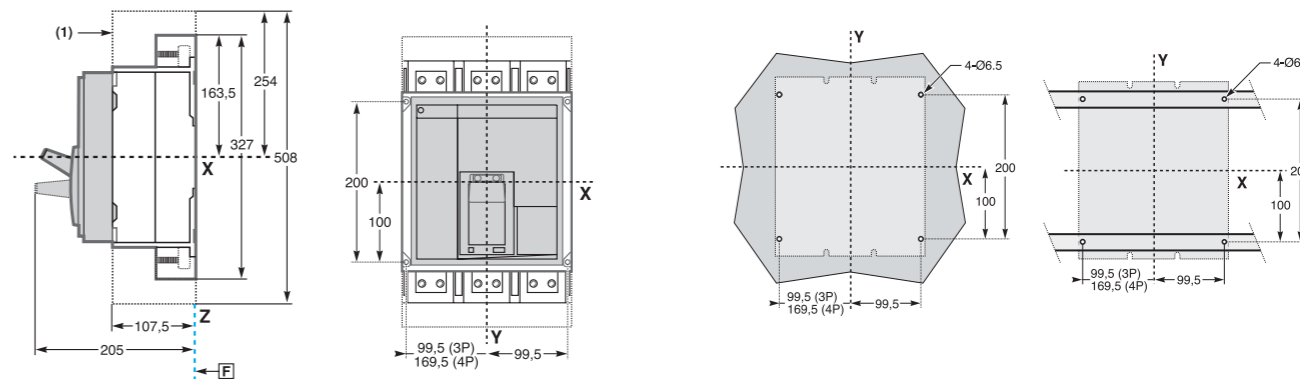

尺寸(mm)

型号 Type	P13	P14	H12	L1	L8	C14	C15
SZM1-100/160/250N/H	98	175	115	105	120	C23	110
SZM1-400/630/H	129	243	175	140	130	180	145

ZMM10 系列塑壳式断路器 Series Molded Case Circuit Breaker

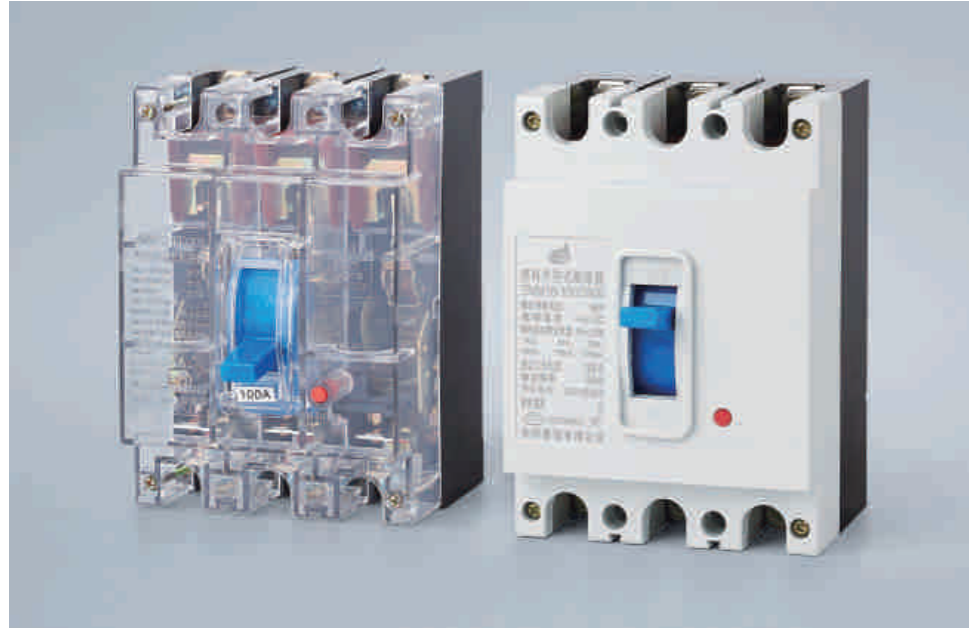

主要技术参数 Main technical data

1、断路器的主要技术参数 Main technical parameters of circuit breaker

型号 Type	额定壳架 等级最大 电流(A) Rated frame current	额定电流In(A) Rated current	功率 损耗W Power loss	额定运行短路分断能力 Rated Service short-circuit breaking capability		额定极限短路分断能力 Rated Ultimate short-circuit breaking capability		飞弧距离 mm Flashover distance
				Ics kA	cos	Ics kA	cos	
ZMM10-100	100	15,20,25,30, 40,50,60,80,100	25	5	0.5	10	0.3	200
ZMM10-250	250	100,120(125),140(150), 170,200(225),250	55	10	0.3	20	0.25	200
ZMM10-600	600	200,250,300,350, 400,500,600	130	12.5	0.3	25	0.25	250

注：括号内的额定电流等级为特殊规格，用户需要时，制造厂可特殊设计。

Note: The rated current level in the bracket is regarded as special specification, if necessary, the manufacturer can make special design for you.

2、控制电路的主要技术参数 Main technical parameters of control circuit

类别 Sort		额定工作电压 V Rated Working Voltage		
		AC 50Hz	DC	
脱扣器 Release	分励脱扣器 Shunt release	Us	230、400	24、110、220
	欠电压脱扣器 Under voltage release	Ue	230、400	-
电动机机构 Electric mechanism		Us	230、400	-

3、辅助触头的主要技术参数 Main technical parameters of auxiliary contact

约定发热电流 Ith (A) Conventional thermal current	额定绝缘电压 Ui(V) Rated insulation Voltage	额定工作电流Ie A Rated working current		适用壳架等级的最 大的额定电流 A Rated frame current
		AC400V	DC220V	
3	400	0.26	0.15	225A及以下
		0.4	0.2	400A及以上

适用范围 Application

ZMM10系列塑料外壳式断路器(以下简称断路器)适用于交流50Hz(或60Hz)、额定电流15A至600A、额定绝缘电压690V、额定工作电压400V及以下。本系列断路器在配电网中用来分配电能,作为线路及电气设备的过载、短路保护和欠电压保护之用,在正常情况下,断路器也可作为线路不频繁转换之用。250A壳架等级及以下的断路器亦可作为保护电动机和电动机的不频繁启动之用。

产品符合GB 14048.2、GB 14048.4和IEC 60947-2、IEC 60947-4标准。

ZMM10 series molded case circuit breaker (hereinafter referred to as circuit breaker) is suitable for distributing network of AC 50Hz (or 60Hz), rated current 15~600A, rated insulation voltage 690V and rated working voltage 400V or below. It can be used to distribute electric energy and protect the circuit and electric equipment against overload, short circuit and under voltage, under normal condition, the circuit breaker also can be used to switch the circuit infrequently. Circuit breakers of frame size 250A and below also can be used to protect motor or infrequently start motor.

The products are in conformity with GB 14048.2, GB 14048.4, IEC 60947-2 and IEC 60947-4.

4、短路保护电流整定值 Setting value of short-circuit protection current

型号 Type	配电保护用试验电流 Test current for distribution protection	保护电动机用试验电流 Test current for motor protection	整定值的准确度 Accuracy of setting value	约定时间s Conventional time	起始状态 Intiap state
ZMM10-100、250	10In	12In	± 20%	< 0.2脱扣 Trip	冷态 Cold state
ZMM10-600		-			

5、配电保护用断路器反时限断开动作特性

Inverse time lag breaking characteristics of circuit breaker for distribution protection

试验电流名称 Name of test current	电流整定倍数 Current setting multiple	约定时间 T Conventional time			起始状态 Intiap state	基准温度 Ambient temperature
		1.01In 100A	63A < In 225A	225A < In		
约定不脱扣电流 Conventional non-tripping current	1.05In	1h	2h		冷态 Cold state	+30
约定脱扣电流 Conventional tripping current	1.30In	< 1h	< 2h		热态 Hot state	
可返回时间 Returnable time	3.0In	可返回时间 Returnable time			冷态 Cold state	
		5s	8s	12s		

6、电动机保护用断路器反时限断开动作特性

Inverse time lag characteristics of circuit breaker for motor protection

试验电流名称 Name of test current	电流整定倍数 Current setting multiple	约定时间 T Conventional time		起始状态 Intiap state	基准温度 Ambient temperature
		1.01In 100A	100A < In 250A		
约定不脱扣电流 Conventional non-tripping current	1.01In	2h		冷态 Cold state	+40
约定脱扣电流 Conventional tripping current	1.2In	< 2h		热态 Hot state	
	1.5In	2min	4min	热态 Hot state	
返回特性电流 Current of returning characteristic	7.2In	2s < t 10s	4s < t 10s	冷态 Cold state	

外形及安装尺寸 Outline & installation size

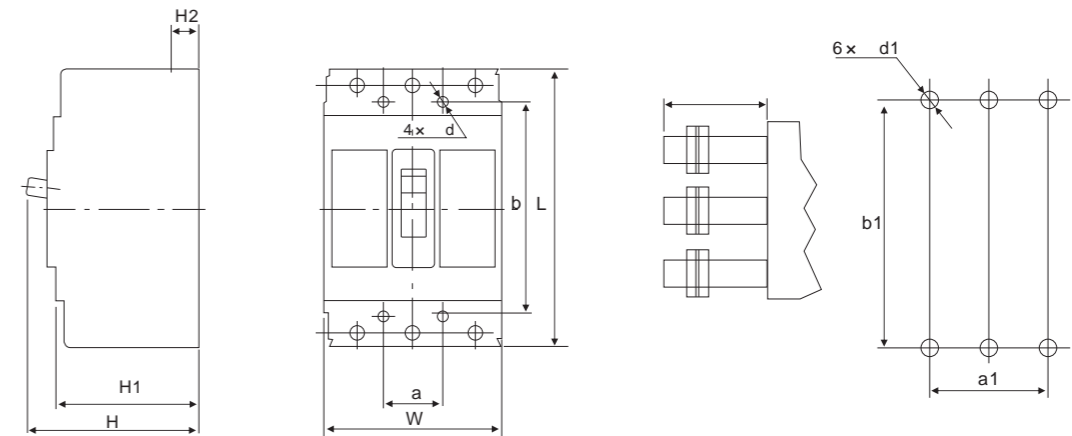

型号 Type	外形尺寸 Outline size					安装尺寸 installation size			板后接线尺寸 connection size			
	L	W	H	H1	H2	a	b	d	a1	b1	d1	H3
ZMM10-100	153	108	104	83	23.5	35	135	5	70	131	6	53
ZMM10-250	276	155	142	105	34	51	240	10	102	238	10	54
ZMM10-600	396	210	147	109	39	70	361	11	140	325	12	45

DZ15

系列塑壳式断路器

Series Molded Case Circuit Breaker



主要技术参数 Main technical data

型号 Type	壳架等级的最大额定电流(A) Rated frame current	额定电流(A) Rated current	极数 Pole	额定电压 Un(V) Rated voltage	额定极限短路分断能力 Icu kA Rated Ultimate short-circuit breaking capability	飞弧距离 (mm) Flashover distance
DZ15-40	40	6,10,16,20,25,32,40	1	220	3	50
			2			
			3			
DZ15-100	100	50,63,80,100	3	380	5	70

配电保护用断路器过电流脱扣器保护特性 Inverse time lag breaking characteristics of circuit breaker for distribution protection

周围空气温度 Ambient temperature	配电保护用断路器 Distribution protection			起始状态 Intiup state
	电流整定倍数 Current setting multiple	约定时间 Conventional time		
+30 ±2	1.05In	1h内不脱扣	2h内不脱扣	冷态 Cold state
	1.30In	1h内脱扣	2h内脱扣	热态 Hot state
	3.00In	可返回时间 2s		冷态 Cold state
在任何合适温度下	10.00In	< 0.2s脱扣		冷态 Cold state
+20 ±2	1.05In	1h内不脱扣	2h内不脱扣	冷态 Cold state
	1.30In	1h内脱扣	2h内脱扣	热态 Hot state

电动机保护用断路器过电流脱扣器保护特性 Inverse time lag characteristics of circuit breaker for motor protection

周围空气温度 Ambient temperature	电动机保护用断路器 Motor protection			起始状态 Intiup state	
	电流整定倍数 Current setting multiple	约定时间 Conventional time			
+20 ±2	1.05In	2h内不脱扣 No trip		冷态 Cold state	
	1.20In	2h内脱扣 Trip		热态 Hot state	
	1.50In	< 2min脱扣 Trip		热态 Hot state	
	6.0In	可返回时间 > 1s		冷态 Cold state	
在任何合适温度下	12.00In	< 0.2s脱扣 Trip		冷态 Cold state	
-5 ±2	1.05In	2h内不脱扣 No Trip		冷态 Cold state	
	1.30In	2h内脱扣 Trip		热态 Hot state	
	1.00In	2h内不脱扣 No Trip		冷态 Cold state	
+40 ±2	1.00In	2h内不脱扣 No Trip		冷态 Cold state	
	1.20In	2h内脱扣 Trip		热态 Hot state	

适用范围 Application

DZ15系列塑壳式断路器(以下简称断路器)适用于交流50Hz、额定电压至380V,额定电流至100A的电路中作为分配电能用,并可用来保护线路和电动机的过载及短路,亦可作为线路的不频繁转换及电动机的不频繁起用之用。

产品符合GB 14048.2、GB 14048.4和IEC 60947-2、IEC 60947-4标准。

DZ15 series molded case circuit breaker (hereinafter referred to as circuit breaker) is suitable for circuit of AC 50Hz, rated voltage 380V, rated current 100A, used to distribute electric energy and protect the circuit and motor against over load and short circuit, it also can be used to switch circuit and start motor infrequently. The products are in conformity with such standards as GB 14048.2, GB 14048.4, IEC 60947-2 and IEC 60947-4.

外形及安装尺寸 Installation Size

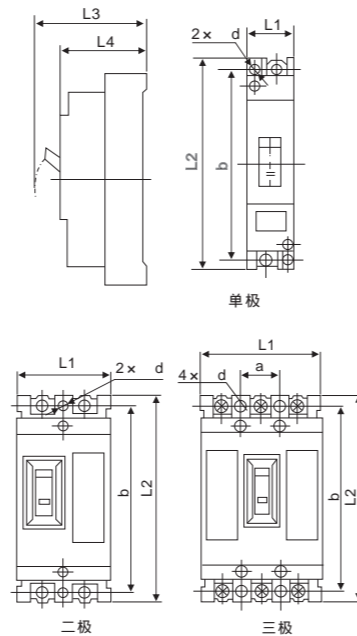

型号 Type	极数 Pole	外形尺寸 Outline size				安装尺寸 Installation size		
		L1	L2	L3	L4	a	b	c
DZ15-40	1	27 ± 1.05	134 ± 2.0	88 ± 1.75	73.5 ± 1.5	-	120 ± 0.435	-
	2	53 ± 1.5	134 ± 2.0	88 ± 1.75	73.5 ± 1.5	-	120 ± 0.435	5 ^{+0.3} ₀
	3	78 ± 1.5	134 ± 2.0	88 ± 1.75	73.5 ± 1.5	25 ± 0.26	120 ± 0.435	-
DZ15-100	3	96 ± 1.75	147 ± 2.0	96 ± 1.75	80 ± 1.5	30 ± 0.26	130 ± 0.435	7 ^{+0.36} ₀

DZ15D

型多功能自动保护开关

Multifunction Automatic Protection Switching



适用范围 Application

我厂生产的DZ15D^{10-40A}_{50-100A}/^{100-250A}/3902 型多功能自动保护开关,集断相、过流、短路保护为一体,即可以对运行在380V 50Hz交流线路的电动机进行多方面的自动保护,又可作为不频繁启动电动机的开关,并且对配电变压器的跌落开关掉闸或总保险丝熔断而引起的多台电动机缺相运行导致变压器过流损坏的事故起到一定的预防作用。

此保护开关优点解决了市场上多种开关高压断相(跌落开关掉闸)不起作用的难题。不论是高压跌落开关掉闸,低压保险烧坏,电动三相绕组一相不通点电造成缺相运行都能可靠的起到保护作用。

Our DZ15D^{10-40A}_{50-100A}/^{100-250A}/3902 type multifunctional auto protective switch is mixed with the protection functions of phase failure, over-current, short circuit faults, able to provide the automatic protection for the motors under AC 380V, 50Hz, also used to start motor non-frequently, further to some degree, prevent the accident of distribution transformer destroyed resulted from over-current because motors run at failure of one phase caused one phase of drop out fuse melted down.

The merit of this switch has solved the problem that many switches can't take action while the one phase of drop out fuse is melted down, no matter drop out fuse melted down, low voltage fuse burnt, one phase of three phase motor is broken, which make it run at phase absence, it can perform the effective protection.

型号及其含义 Code and implication

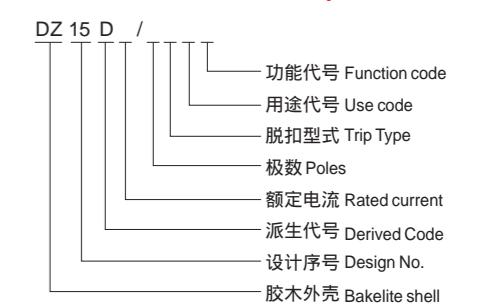

结构与工作原理 Structure and working principle

- 本多功能保护开关是一种快速反应的电机保护综合开关,全部零件装在胶木壳中。(工作原理如图一)
- 断相信号从三个串联的互感器中提取。
- 当电动机缺相运行时,串联互感器两输出端便输出一个断相信号,该信号触发电子触发器驱动脱扣器打开自动开关,从而达到保护电动机的目的。
- 当电动机流过短路时,过流脱扣器便及进脱扣打开自动开关,(本过流,短路器分电子式和液压式两种)从而达到保护电动机的目的。

- This protective switch is a comprehensive switch for motor with fast response, all parts assembled in bakelite shell. (Working theory as picture 1)
- The signal of phase failure come from three series connected CTs.
- When the motor run at phase absence, the CT will output a signal of phase failure, to touch off electric trigger and drive release to open the switch, consequently protect the motor.
- When motor happen to over-current or short circuit, the o/c release will drive switch to open the line, (o/c and s/c releases have two kinds: electronic type and hydraulic type), namely protect the motor.

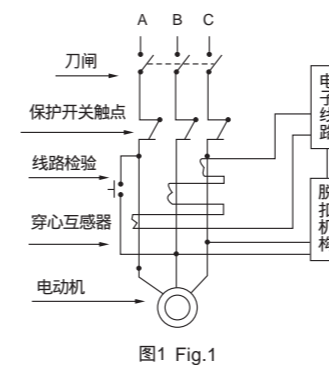

主要技术参数 Main technical data

- 自动开关过流脱扣特性表
Automatic switch overcurrent tripping characteristics table

脱扣器额定电流倍数 Rated current multiples	动作时间 Action time
1.0	不动作 No action
1.2	<20分钟 <20min
1.5	<3分钟 <3min
6.0	可返回时间 <4秒 To return time <1 s
12.0	<2秒 <2 s

- 多功能自动开关参数
Multi-functional automatic switch parameter

基本项目 Items	参数Data
额定电压 Rated voltage	380
额定电流 Rated current	40,100,250
额定频率 Rated frequency	50
段数 Number of segments	3
过流脱扣器额定电流 Over-current release rated current	40,60,100,250
断相动作时间 Off phase action time	3
电机漏电动作电流 Motor leakage current	75

正常工作条件 Normal operating conditions

- 海拔高度不超过2500米;
- 没有雨雪侵蚀的地方;
- 无爆炸危险的介质中并且无腐蚀和破坏绝缘的气体与导电尘埃的地方。
- Altitude: not higher than 2500m
- No place rain and snow erosion;
- No explosive medium and no corrosion and damage the insulation of gas and conductive dust areas.

DZ20

系列塑壳式断路器

Series Molded Case Circuit Breaker



外形及安装尺寸 Outline & installation size

型号 Type	极数 Pole	外形尺寸 Outline size						安装尺寸 Installation size			板后接线尺寸 Connection size					
		L	L1	L2	W	H	H1	H2	a	b	d	a1	b1	d1	H3	H4
DZ20Y,J-100	3	-	-	105	103	86.5	26	35	126	4	70	147	8	64	64	
	4	165	-	50	140	103	86.5	26	70	126	4	105	147	8	64	
DZ20Y,W,JW-100	3	165	-	50	105	103	86.5	26	35	126	4	70	147	8	64	
DZ20G-100	3	165	-	50	105	156.5	140	26	35	126	4	70	147	8	64	
DZ20C-160	3	155	-	50	108	106.5	84	20	35	135	4	70	141	8	-	
	4	257.5	327	103	109.5	138	103	20	35	196	4	70	213	8	32	
DZ20Y,J-225	3	257.5	327	103	109.5	138	103	20	35	196	4	70	213	8	32	
DZ20G-225	3	257.5	327	103	109.5	227	187	20	35	196	4	70	213	8	32	
DZ20C-250	3	208	-	103	109	142	103.5	20	35	184	4	70	210	8	-	
	4	276	390	104	156	148	110	22	51	240	6	102	242	6	55	
DZ20Y-400	3	276	390	104	156	148	110	22	51	240	6	102	242	6	55	
DZ20C,YW-400	3	276	390	104	156	148	110	22	51	240	6	102	242	6	55	
DZ20G-400	3	268	369	102.5	209	247	208	23	70	200	6	140	234.5	6	55	
DZ20J,JW-400	3	268	369	102.5	209	148	110	23	70	200	6	140	234.5	6	55	
DZ20Y,J-630	3	268	369	102.5	209	148	108	23	70	200	6	140	234.5	6	55	
	4	406	546	104.5	209	178	122.5	40	70	375	8	140	371.5	13	-	
DZ20C,YW,JW-630	3	268	369	102.5	209	148	108	23	70	200	6	140	234.5	6	55	
DZ20-1250	3	406	546	104.5	209	178	122.5	40	70	375	8	140	371.5	13	-	

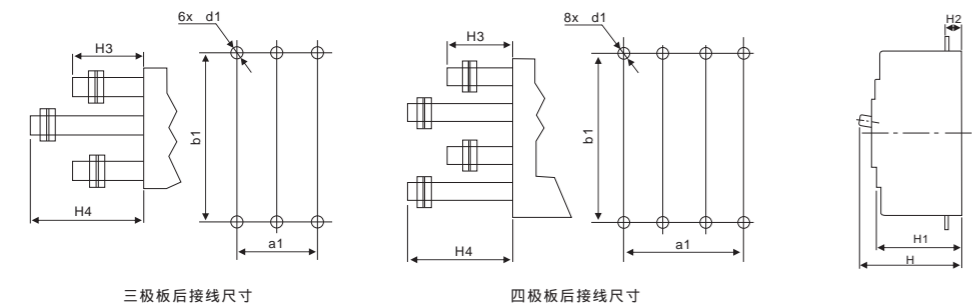

适用范围 Application

DZ20系列塑料外壳式断路器和DZ20 W无飞弧断路器(以下简称断路器)适用于交流50Hz(或60Hz),额定电流至1250A,额定绝缘电压690V,额定工作电压380(400)V及以下的配电线路中,作为分配电能和线路及电源设备的过载、短路和欠电压保护。其中Y、J、G型额定电流225A及以下和Y型400A及以下的断路器亦可作为保护电动机用,在正常情况下,可分别作为线路的不频繁转换及电动机的不频繁启动之用。

产品符合GB 14048.2、GB 14048.4和IEC 60947-2、IEC 60947-4标准。

DZ20 series molded case circuit breaker and DZ20 W no-flashover circuit breaker (hereinafter referred to as circuit breaker) are suitable for distributing line of AC 50Hz (or 60Hz), rated current 1250A, rated insulation voltage 690V and rated working voltage 380 (400)V or below, used to distribute electric energy and protect circuit and power equipment against overload, short circuit and under voltage. Hereinto, type Y, J, G circuit breakers of rated current 225A and type Y circuit breakers of rated current 400A and below also can be used to protect motor. Under normal condition, they also can be applied to switching circuit and starting the motor infrequently respectively.

The products are in conformity with such standards as GB 14048.2, GB 14048.4, IEC 60947-2 and IEC 60947-4.

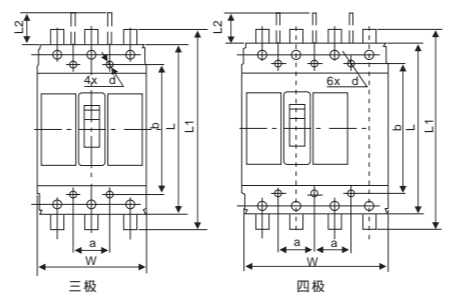

主要技术参数 Main Technical data

1、断路器的主要技术参数 Main technical parameters of circuit breaker

型号 Type	壳架等级最大 额定电流(A) Rated frame current	额定电流In(A) Rated current	功率损耗W Power loss		短路分断能力(有效期) Short circuit breaking capacity (time of effect)		飞弧距离 mm Flashover distance
			固定式 Fixing type	插入式 Insertion type	Ics/Cos	Ics/Cos	
DZ20C-160	160	16,20,25,32,40,50,63,80,100,125,160	40	50	12/0.30	/	80
DZ20Y-100	100	16,20,25,32,40,50, 63,80,100	30	35	18/0.30	14/0.30	80
DZ20J-100			35	40	35/0.25	18/0.30	
DZ20G-100			40	50	100/0.20	50/0.25	
DZ20C-250	250	100,125,160,180,200,225,250	45	55	15/0.20	/	80
DZ20Y-225	225	100,125,160,180,200,225	40	50	25/0.25	19/0.30	80
DZ20J-225			50	65	42/0.25	25/0.25	
DZ20G-225			60	80	100/0.20	50/0.25	
DZ20C-400	400	200,250,315,350,400	65	80	20/0.30	/	100
DZ20Y-400			75	90	30/0.25	23/0.25	
DZ20J-400			85	110	42/0.25	25/0.25	
DZ20G-400			120	150	100/0.20	50/0.25	
DZ20C-630	630	400,500,630	95	120	20/0.30	/	100
DZ20Y-630			105	130	30/0.25	23/0.25	
DZ20J-630			105	130	50/0.25	25/0.25	
DZ20G-1250	1250	630,700,800,1000,1250	240	300	65/0.20	32.5/0.25	120

2、控制电路的主要技术参数

Main technical parameters of control circuit

类别 Sort	额定工作电压(V) Rated Working Voltage			
	AC 50Hz	DC		
脱扣器 Release	分励脱扣器 Shunt release	Us	230, 400	24, 110, 220
	欠电压脱扣器 Under voltage release	Ue	230, 400	-
电动机机构 Electric mechanism	Us	230, 400	-	

3、辅助触头和报警触头的主要技术参数

Main technical parameters of auxiliary contact and alarm contact

约定发热电流 Ith A Conventional thermal current	额定绝缘电压Ui V Rated insulation Voltage	额定工作电流Ie A Rated working current		适用壳架等级的 最大额定电流A Rated frame current
		AC400V	DC220V	
1	400	0.3	0.15	作报警触头用 Used as alarm contact
2	400	0.4	0.15	250A及以下
3	400	3	0.2	400A及以上

4、短路保护电流整定值

型号 Type	配电用 distribution protection	电机保护用 motor protection	整定值的准确度 Accuracy of setting value	约定时间s Conventional time	起始状态 Intiap state
DZ20Y,J,G, YW, JW-100	10In	12In	±20%	< 0.2脱扣 Trip	冷态 Cold state
DZ20Y,J,G, YW, JW-225	5In,10In				
DZ20Y, YW-400	10In				
DZ20J,G, JW-400	5In,10In	-	±20%	< 0.2脱扣 Trip	冷态 Cold state
DZ20Y,J, YW, JW-630					
DZ20J-800	5In,10In				
DZ20J-1250	4In,7In				

5、配电用断路器反时限特性

Inverse time lag breaking characteristics of circuit breaker for distribution protection

试验电流名称 Name of test current	电流整定倍数 Current setting multiple	约定时间 T Conventional time			起始状态 Intiap state	基准温度 Ambient temperature
		1.01In 100A	63A < In 225A	225A < In		
约定不脱扣电流 Conventional non-tripping current	1.05In	1h	2h		冷态 Cold state	+30
约定脱扣电流 Conventional tripping current	1.30In	< 1h	< 2h		热态 Hot state	
可返回时间 Returnable time	3.0In	可返回时间T Returnable time			冷态 Cold state	
		5s	8s	12s		

6、电动机保护用断路器反时限特性

Inverse time lag characteristics of circuit breaker for motor protection

试验电流名称 Name of test current	电流整定倍数 Current setting multiple	约定时间 T Conventional time	起始状态 Intiap state	基准温度 Ambient temperature
约定不脱扣电流 Conventional non-tripping current	1.01In	2h	冷态 Cold state	+40
约定脱扣电流 Conventional tripping current	1.2In	< 2h	热态 Hot state	
返回特性电流 Current of returning characteristic	1.5In	4min	热态 Hot state	
	7.2In	4s < TP 10s	冷态 Cold state	

SZM1LE

系列漏电断路器

Series Earth Leakage Circuit Breaker



过电流特性曲线 Characteristic curve

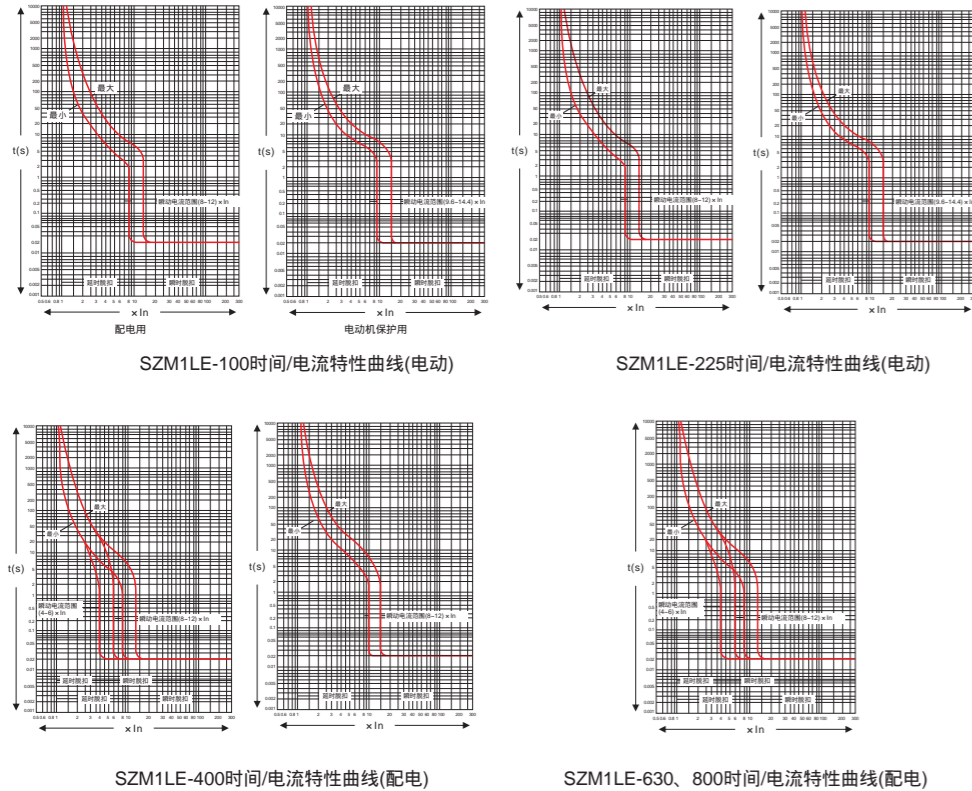

适用范围 Application

SZM1LE系列剩余电流断路器(以下简称断路器),主要适用于交流50Hz,额定电压400V,额定电流至800A的配电网络中,用来对人提供间接接触保护,也可用来防止因设备绝缘损坏,产生接地故障电流而引起的火灾危险,并可用来分配电能和保护线路及电源设备的过载和短路,还可作为线路的不频繁转换和电动机不频繁启动之用。常规的带剩余电流保护断路器的漏电保护模块工作电源取样为二相,本系列断路器为三相,若缺一任一相,断路器漏电保护模块仍能正常工作;额定剩余动作电流及最大断开时间根据实际情况现场可调;当相电压降低至50V,漏电保护模块仍能正常工作;具有漏电报警输出功能。

SZM1LE series residual current circuit breaker (hereinafter referred to as circuit breaker) is suitable for distributing network of AC 50Hz, rated voltage 400V, rated current 800A, to make indirect contact protection to the human being, also to prevent fire accident caused by ground fault current due to the damage of insulation of equipment. In addition, it not only can be used to distribute electric energy and protect the circuit and power equipment against overload and short circuit, but also can be used to switch the circuit or start the motor infrequently. The sampling operational power supply of leakage protection module of common residual current circuit breakers is two phases, but this series of circuit breakers is three phases, and if any one of three phases is lack, this circuit breaker leakage protection module can still work normally. The rated residual operation current and max breaking time may be adjusted according to practical situations. Provided that the phase voltage declines to 50V, the leakage protection module can still work normally. In addition, this circuit breaker has function of leakage alarm output.

主要技术参数 Main Technical data

型号 Type	SZM1LE-100			SZM1LE-225			SZM1LE-400			SZM1LE-630、800											
壳架等级最大的额定电流Inm(A) Rated frame current	100			225			400			800											
额定电流In(A) Rated current	10	16	20	25	32	100	125	140	160	225	250	315	400	500	630						
	40	50	63	80	100	180	200	225	350	400	700	800	700	800							
极数 Pole	3			4			3			4											
额定绝缘电压Ui(V) Rated insulation Voltage	AC800																				
额定工作电压Ue(V) Rated Working Voltage	AC400																				
额定冲击耐受电压Uimp (V) Rated impulse withstand voltage	8000			8000			8000			8000											
飞弧距离(mm) Flashover distance	50			50			100			100											
分断能力级别 Breaking capacity class	L	M	H	L	M	H	L	M	H	L	M	H									
极限短路分断能力Icu (kA) Ultimate short-circuit breaking capability	AC400V																				
运行短路分断能力Ics (kA) Service short-circuit breaking capability	AC400V																				
额定剩余短路接通(分断)能力Im (kA) Rated residual making and breaking capability	8.75	12.5	21	8.75	12.5	21	12.5	17.5	25	12.5	17.5	25									
额定剩余动作电流In (mA) Rated residual action current	非延时型 Non-time delay type			30/100/500			100/300/500			100/300/500			300/500/1000								
	延时型 Time delay type			100/300/500			100/300/500			100/300/500			300/500/1000								
额定剩余不动作电流Ino (mA) Rated residual non-action current	1/2			n			1/2			n			1/2			n					
操作性能次 Operating performance	通电 Power on			1500			1000			1000			1000								
	不通电 Power off			8500			7000			4000			4000								
	总次数 Total times			10000			8000			5000			5000								
剩余电流保护动作时间 Residual current protection operating time	n			2			n			5			n			10			n		
最大分断时间s Max breaking time	非延时型 Non-time delay type			0.2			0.1			0.04			0.04								
	延时型 Time delay type			0.5/1.15/2.15			0.35/1/2			0.25/0.9/1.9			0.25/0.9/1.9								

外形及安装尺寸 Outline & installation size

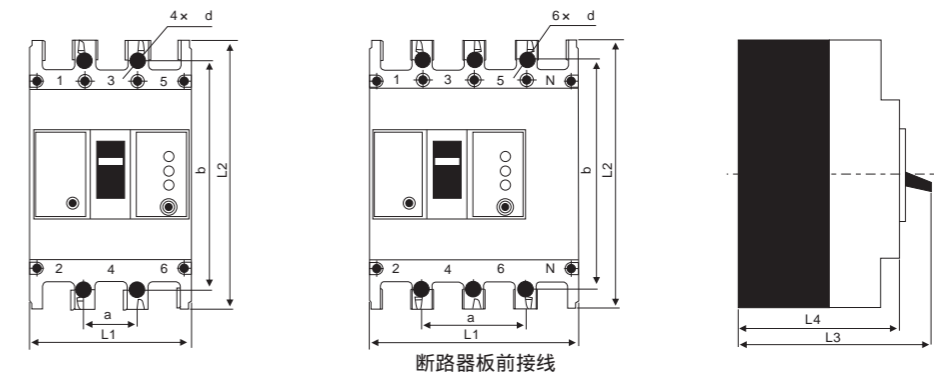

型号 Type	极数 Pole	外形尺寸 Outline size				安装尺寸 installation size		
		L1	L2	L3	L4	a	b	d
SZM1LE-100L	3	92max	150max	94max	75max	30	129	4 x 4.5
	4	122max	150max	94max	75max	60	129	6 x 4.5
SZM1LE-100M	3	92max	150max	110max	92max	30	129	4 x 4.5
	4	122max	150max	110max	92max	60	129	6 x 4.5
SZM1LE-225L	3	107max	165max	94max	72max	35	129	4 x 4.5
	4	142max	165max	94max	72max	70	126	6 x 4.5
SZM1LE-225M	3	107max	165max	110max	90max	35	126	4 x 4.5
	4	142max	165max	110max	90max	70	126	6 x 4.5
SZM1LE-400L,M	3	154max	257max	146max	103max	44	194	4 x 4.5
	4	198max	257max	146max	103max	44	194	6 x 6.5
SZM1LE-800L,M	3	210max	280max	146max	103max	70	243	4 x 7
	4	280max	280max	146max	103max	70	243	6 x 7

SZM1(NSLE)

系列剩余电流动作断路器

Series Residual Current Operated Circuit Breaker



正常工作条件 Normal operating conditions

- 产品安装地点的海拔高度2000m及以下；
- 剩余电流动作断路器安装场所的外磁场在任何方向不超过地磁场的5倍；智能脱扣器的动作值不受温度波动影响。但剩余电流动作断路器的最大允许电流仍与环境温度有关。
- The mounting altitude not more than 2000m.
- The outer magnetic field around the mounting site shall not exceed 5 times of earth magnetic density.
- The tripping value of intelligent release is independent from the change of temperature, but the maxi permissible current of RCCB is related to ambient temperature.

SZM1(NSLE)-100, 250		40	45	50	55	60	65	70
固定值	In : 250A	250	250	250	240	230	220	210
	I _r 最大值	250	250	250	220	210	195	175
SZM1(NSLE)-630		40	45	50	55	60	65	70
固定值	In : 630A	630	615	600	585	570	550	535
	I _r 最大值	630	584	558	526	502	468	444

- 湿热：大气相对湿度在周围空气温度+40℃时不超过50%，在较低温度下可以有较高的相对湿度，最湿月的月平均最大相对湿度为90%，同时，该月的月平均最低湿度为+25℃，并考虑到因温度的变化发生在产品表面上的凝露。
- 污染等级：污染等级为3级。
- When the ambient air temperature is +40°C, the relative humidity of the air shall not be higher than 50%; a higher relative humidity is allowed at a lower temperature; for example, for the wettest month, the maximum relative humidity averaged shall be 90% while the lowest temperature averaged in that month +20°C, and special measures shall be taken for the condensation occasionally produced due to temperature change.
- Pollution grade: III

订货须知

用户订货时需注明：

剩余电流动作断路器的名称及型号、额定电流、额定剩余动作电流、分断时间、保护种类、极数及数量、内部附件和外部附件的种类及额定值。例如：订货SZM1(NSLE)热磁式壳架等级额定电流250A, 标准型分断能力, 额定电流250A, 4极且N极带保护, 并与其它三极一起合分, 电动机保护型, 额定剩余动作电流(A): 0.1~0.3~0.5~1; 额定剩余电流分断时间(s): 0.1~0.3~0.5~1。标准旋转手柄, 并带有AC220V欠电压脱扣器和辅助触头的剩余电流动作断路器100台。

剩余电流动作断路器订货代号：SZM1(NSLE)-250S/250/4C/M、RCD24、100台。

剩余电流动作断路器附件订货代号：SZM1(NSLE)-250S+RH22 +UM5+AX-8/M/8、100台

适用范围 Application

SZM1(NS)塑料外壳式断路器很方便地组装上剩余电流保护模块后即成为SZM1(NSLE)剩余电流动作断路器。SZM1(NSLE)系列剩余电流动作断路器主要适用于交流50Hz, 额定电压至400V, 额定电流至630A的电路中。其主要功能是对有致命危险的人身触电提供间接接触保护, 同时, 还可用来防止由于接地故障电流而引起的电气火灾。并可用来保护线路的过载、短路和欠电压, 亦可作为线路的不频繁转换之用。符合标准：GB 14048.2、IEC 60947-2。

SZM1(NS) moulded case circuit breaker assembled with residual current protective module, become SZM1(NSLE) RCCB. SZM1(NSLE) is mainly operated in the circuit of AC 50Hz, rated voltage up to 400V, rated current up to 630A. The main function is to protect personnel from indirect electric shock, meanwhile used to prevent the electric fire danger caused by earthing fault current, also used to protect from overloading, short circuit and under-voltage faults, and switch on/off the line non-frequently. The product complies with the standards of GB 14048.2、IEC 60947-2

Ordering information

Notices when to book the products :

Name, model, rated current, rated residual tripping current, breaking time, protection kinds, number of poles, qty, internal and outer accessories and their ratings. Such as: book the SZM1(NSLE) thermo-magnetic type, rated frame current 250A, standard breaking capacity, rated current 250A, 4 poles, its N pole with protection, switched on/off together with other 3 poles, motor protected type, rated residual tripping current (A): 0.1~0.3~0.5~1; breaking time at rated residual current (s): 0.1~0.3~0.5~1. standard rotation handle, with AC220V under-voltage release and auxiliary contact, 100pcs.

Purchase code of RCCB: SZM1(NSLE)-250S/250/4C/M、RCD24、100pcs

Purchase code of RCCB accessories: SZM1(NSLE)-250S+RH22 +UM5+AX-8/M/8、100 pcs

断路器脱扣方式及附件代号 Tripping modes and accessory code

附件名称 Accessory name	不加附件 Without accessories	报警触头 Alarm contact	分励脱扣器 Shunt release	辅助触头 Auxiliary contact	欠电压脱扣器 Under-voltage release	分励脱扣器及辅助触头 Shunt release and Auxiliary contact	分励脱扣器及欠电压脱扣器 Shunt release, Under-voltage release	二组辅助触头 Two pairs of Auxiliary contacts	辅助触头及欠电压脱扣器 Auxiliary contact, Under-voltage release	分励脱扣器及报警触头 Shunt release, alarm contact	欠电压脱扣器及报警触头 Under-voltage release, alarm contact	分励脱扣器、辅助触头及报警触头 Shunt release, Auxiliary contact, alarm contact	分励脱扣器、欠电压脱扣器、报警触头 Shunt release, Under-voltage release, alarm contact	二组辅助触头、报警触头 Shunt release, Auxiliary contact, alarm contact	欠电压脱扣器、辅助触头、报警触头 Under-voltage release, Auxiliary contact, alarm contact
脱扣方式 Tripping mode															
电磁瞬时脱扣器 Electromagnetic instantaneous release	200	208	210	220	230	240	250	260	270	218	228	238	248	258	268
复式脱扣器 Combined release	300	308	310	320	330	340	350	360	370	318	328	338	348	358	368

外形及安装尺寸 Outline & installation size

外形尺寸 Dimensions

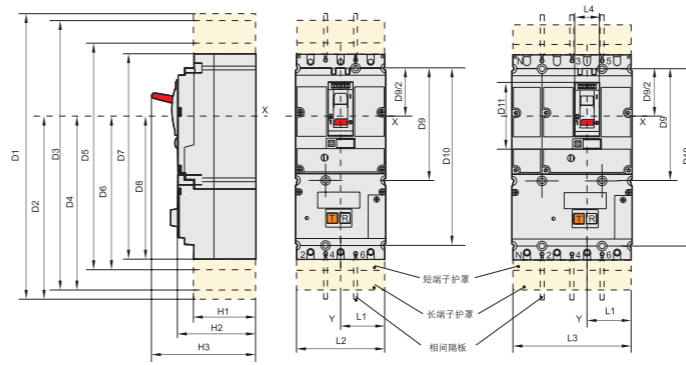

型号 Type	外形尺寸 Dimensions																	
	D1	D2	D3	D4	D5	D6	D7	D8	D9	H1	H2	H3	L1	L2	L3	L4	D10	D11
SZM1(NSLE)-100	305	185	270	167.5	225	145	205	135	112	63	79	108	45	90	120	25	177	54
SZM1(NSLE)-250	432	253.5	396	235.5	263	169	232	153.5	125	73	89	126	52.5	105.5	140	27	200	60
SZM1(NSLE)-630	574	337	580	340	385	242.5	355	227.5	200	95	113	168	70	140	185	52	300	114

联接尺寸 Connection size

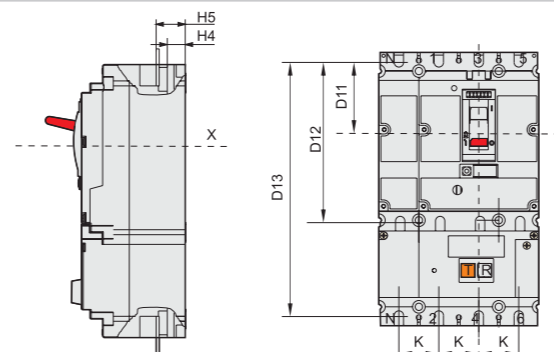

型号	联接尺寸 Connection size					
	D11	D12	D13	H4	H5	K
SZM1(NSLE)-100	63	126	191	19	225	30
SZM1(NSLE)-250	70	140	215	21.5	263	35
SZM1(NSLE)-630	113.5	227	327	26	44	45

安装尺寸 Mounting dimensions

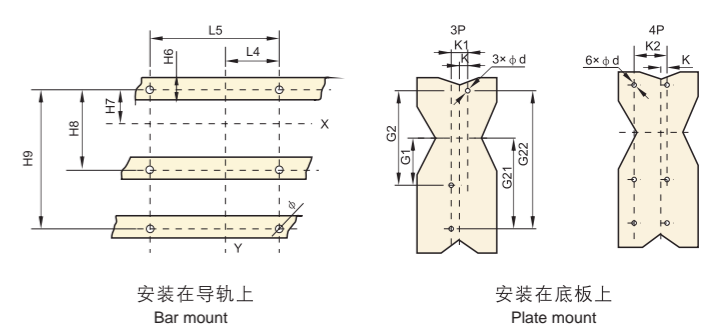

型号	安装尺寸 Mounting dimensions						
	L4	L5(3P/4P)	H6	H7	H8	H9	Ø
SZM1(NSLE)-100	15	30/60	32	56	112	177	6
SZM1(NSLE)-250	17.5	35/70	32	62.5	125	200	6
SZM1(NSLE)-630	22.5	45/90	32	100	200	300	6.5

型号	安装尺寸 Mounting dimensions							
	K	K1	K2	G1	G2	G21	G22	d
SZM1(NSLE)-100	15	30	60	56	112	121	177	6
SZM1(NSLE)-250	17.5	35	70	62.5	125	137.5	200	6
SZM1(NSLE)-630	22.5	45	90	100	200	200	300	6.5

前面板开孔 Front Plate mount size 固定式或插入式剩余电流保护断路器

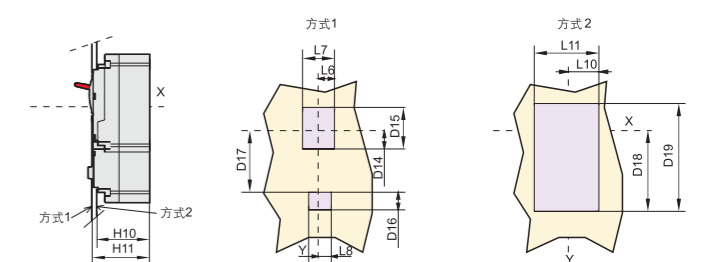

型号 Type	前面板开孔 Front Plate mount size													
	D14	D15	D16	D17	D18	D19	H10	H11	L6	L7	L9	L10	L11(3P/4P)	
SZM1(NSLE)-100	26	68	20	84	115	165	73	80	13	26	13	26	46.5	93/123
SZM1(NSLE)-250	33	78	20	96	132	188	83	90	14.5	29	14.5	29	54	108/143
SZM1(NSLE)-630	41.5	116	29	146.5	202	294	109	114	26.5	53	24	48	71.5	143/188

ZMM10LE

系列漏电断路器

Series Earth Leakage Circuit Breaker



适用范围 Application

ZMM10LE系列漏电断路器，适用于交流50Hz，额定工作电压至400V，额定电流至400A的线路中，作为人身触电和线路设备保护之用，并可用于线路和电源设备的过载保护及短路保护，亦可作为线路的不频繁转换之用。

ZMM10LE series leakage circuit breaker is suitable for circuit of AC 50Hz, rated working voltage 400V, rated current 400A, it can be used to protect the line equipment and human being from getting an electric shock. In addition, it not only can protect the circuit and power equipment against overload and short circuit, but also can be used to infrequently switch the circuit.

主要技术参数 Main Technical data

项目Item	型号Type	ZMM10LE-100	ZMM10LE-250	ZMM10LE-400
Un(V)		230,400		
Inm(A)		100	250	400
In(A)		16,20,25,32,40,50,63,80,100	100,125,160,180,200,250	250,315,350,400,500,630
极数、线数 Pole		三极四线 Three class four-wire		
I n/ I no(mA)		50/25、100/50		200/100
分断时间 Breaking time	I n	0.2s		
	5I n	0.04s		
Icu/Ics(kA)		7/5	18/14	25/19
I m(kA)		1	3	6
不导致误动作的过电流极限值(A) Limit value of over-current that would not cause false operation (A)		6In		
机械寿命(次)(包括电寿命次数) Mechanical life (Electrical life)		8000		7000
电寿命(次) Electrical life		4000		2000
试验装置动作电压(V) Operating voltage of test device (V)		(0.85~1.1)Un		
电磁脱扣器动作电流整定值或范围 Setting value or setting range of operating current of electromagnetic release		10In	(5~10In)	(5~10In)
长延时脱扣器 动作特性 Operating characteristics of long-time delay release	约定不动作电流1.05In Conventional non-action current	1h内不脱扣 No trip	2h内不脱扣 No trip	
	约定动作电流1.3In Conventional action current	1h内脱扣 Trip	2h内脱扣 Trip	

外形及安装尺寸 Outline & installation size

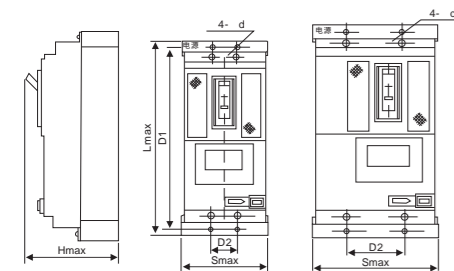

Inm A	极数 Pole	外形尺寸 Outline size			安装尺寸 installation size		
		Lmax	Smax	Hmax	D1	D2	d
100	三极四线 Three class four-wire	275	145	105	202	75	4 5 ^{+0.48}
250		363	205	144	326	102	4 5 ^{+0.48}
400							

DZ15LE

系列漏电断路器

Series Earth Leakage Circuit Breaker



适用范围 Application

DZ15LE系列漏电断路器，适用于交流50Hz，额定工作电压至380V，额定电流至100A的线路中，用来对人员进行间接接触保护，也可用来防止因设备绝缘损坏产生接地故障电流而引起的火灾危险，并可用于保护线路、电动机的过载和短路，亦可作为线路的不频繁转换和电动机不频繁启动之用。

产品符合GB 6829、GB 14048.2和IEC 60755、IEC 60947标准。

DZ15LE series leakage circuit breaker is suitable for circuit of AC 50Hz, rated working voltage 380V and rated current 100A, to make indirect contact protection to the human being, also to prevent fire accident caused by ground fault current due to the damage of insulation of equipment. In addition, it not only can protect the circuit and motor against overload and short circuit, but also can be used to switch the circuit and start the motor infrequently.

The products are in conformity with such standards as GB 6829, GB 14048.2, IEC 60755 and IEC 60947.

主要技术参数 Main Technical data

漏电断路器的主要技术参数
Main technical parameters of circuit breaker

型号 Type	额定电流 In(A) Rated current	额定工作电压 Un V Rated Working Voltage	额定极限短路分断能力Icu kA Rated Ultimate short-circuit breaking capability	飞弧距离 mm Flashover distance	额定剩余动作电流I n mA Rated residual action current	额定剩余不动作电流I no mA Rated residual non-action current	最大分断时间 s Max breaking time s				
							I n	2I n	5I n	I n	5I n
DZ15LE-40	6 10 16 20 25 32 40	220	3	50	30	15	0.1	-	-		
		380			50	25	0.2	0.1	0.04		
					75	40					
					100	50					
DZ15LE-100	50 63 80 100	220	5	70	30	15	0.1	-	-		
		380			50	25	0.2	0.1	0.04		
					75	40					
					100	50					

配电保护用漏电断路器过电流脱扣器保护特性
Inverse time lag breaking characteristics of circuit breaker for distribution protection

周围空气温度 Ambient temperature	配电用漏电断路器 The circuit breaker for distribution protection			起始状态 Intiap state
	电流整定倍数 Current setting multiple	约定时间 Conventional time		
		In 63A	In > 63A	
+30 ±2	1.05In	1h内不脱扣 No trip	2h内不脱扣 No trip	冷态开始 Cold state start
	1.30In	1h内脱扣 trip	2h内脱扣 trip	热态开始 Hot state start
	3.00In	可返回时间 2s Returnable time 2s		冷态开始 Cold state start
在任何合适温度下	10.00In	< 2s脱扣 trip		冷态开始 Cold state start
+20 ±2	1.05In	1h内不脱扣 No trip	2h内不脱扣 No trip	冷态开始 Cold state start
	1.30In	1h内脱扣 trip	2h内脱扣 trip	热态开始 Hot state start

DZ15LE

系列漏电断路器

Series Earth Leakage Circuit Breaker

3、电动机保护用漏电断路器过电流脱扣器保护特性
Inverse time lag characteristics of circuit breaker for motor protection

周围空气温度 Ambient temperature	电动机保护用漏电断路器 The circuit breaker for motor protection		
	电流整定倍数 Current setting multiple	约定时间 Conventional time	起始状态 Intiap state
+20 ±2	1.05I _n	2h内不脱扣 No trip	冷态开始 Cold state start
	1.20I _n	2h内脱扣 Trip	热态开始 Hot state start
	1.50I _n	< 2min内脱扣 Trip	热态开始 Hot state start
在任何合适温度下	6.0I _n	可返回时间 > 1s Returnable time > 2s	冷态开始 Cold state start
	12.00I _n	< 0.2s脱扣 trip	冷态开始 Cold state start
-5 ±2	1.05I _n	2h内不脱扣 No trip	冷态开始 Cold state start
	1.30I _n	2h内脱扣 Trip	热态开始 Hot state start
+40 ±2	1.00I _n	2h内不脱扣 No trip	冷态开始 Cold state start
	1.20I _n	2h内脱扣 Trip	热态开始 Hot state start

外形及安装尺寸 Outline & installation size

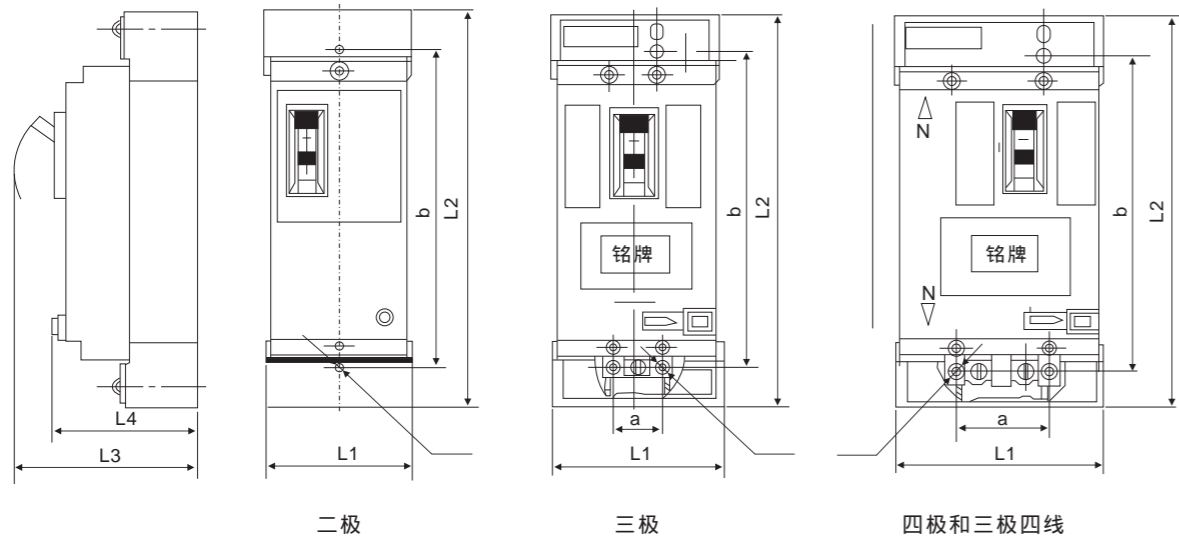

型号 Type	极数 Pole	外形尺寸 Outline size				安装尺寸 installation size		
		L1	L2	L3	L4	a	b	d
DZ15LE-40	2	56 ± 1.5	212 ± 2.3	212 ± 2.3	73.5 ± 1.5	-	180 ± 0.5	2 × 5 ^{+0.3} ₀
	3	82 ± 1.75	221 ± 2.3	221 ± 2.3	73.5 ± 1.5	25 ± 0.26	180 ± 0.5	4 × 5 ^{+0.3} ₀
	4	107 ± 1.75	221 ± 2.3	221 ± 2.3	73.5 ± 1.5	50 ± 0.31	180 ± 0.5	4 × 5 ^{+0.3} ₀
DZ15LE-100	2	70 ± 1.5	230 ± 2.3	230 ± 2.3	82 ± 1.5	-	188 ± 0.5	2 × 7 ^{+0.36} ₀
	3	100 ± 1.75	254 ± 2.6	254 ± 2.6	80 ± 1.5	30 ± 0.26	210 ± 0.575	4 × 7 ^{+0.36} ₀
	4	130 ± 2.0	254 ± 2.6	254 ± 2.6	80 ± 1.5	60 ± 0.37	210 ± 0.575	4 × 7 ^{+0.36} ₀

DZ15LED

电子式漏电断路器 / 断相过流自动保护开关

Electronic leakage circuit breakers/OFF phase over-current protection switch



结构与工作原理 Structure and working principle

- 本多功能保护开关是一种快速反应的电机保护综合开关，全部零件装在胶木壳中。（工作原理如图一）
- 断相信号从三个串联的互感器中提取。
- 当电动机缺相运行时，串联互感器两输出端便输出一个断相信号，该信号触发电子触发器驱动脱扣器打开自动开关，从而达到保护电动机的目的。
- 当电动机过流短路时，过流脱扣器便及进脱扣打开自动开关，（本过流，短路器分电子式和液压式两种）从而达到保护电动机的目的。

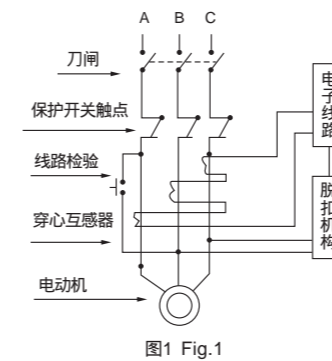

主要技术参数 Main technical data

- 自动开关过流脱扣特性表
Automatic switch overcurrent tripping characteristics table

脱扣器额定电流倍数 Rated current multiples	动作时间 Action time
1.0	不动作 No action
1.2	≤20分钟 ≤20min
1.5	≤3分钟 ≤3min
6.0	可返回时间 ≤4秒 To return time <1 s
12.0	≤2秒 ≤3 s

- 多功能自动开关参数
Multi-functional automatic switch parameter

基本项目 Items	参数Data
额定电压 Rated voltage	380
额定电流 Rated current	40,100,250
额定频率 Rated frequency	50
段数 Number of segments	3
过流脱扣器额定电流 Over-current release rated current	40,60,100,250
断相动作时间 Off phase action time	3
电机漏电动作电流 Motor leakage current	75

适用范围 Application

我厂生产的DZ15LED^{10-40A}_{50-100A}/^{100-250A}/3902 型多功能自动保护开关，集断相、过流、短路保护为一体，即可以对运行在380V 50Hz交流线路的电动机进行多方面的自动保护，又可作为不频繁启动电动机的开关，并且对配电变压器的跌落开关掉闸或总保险熔断而引起的多台电动机缺相运行导致变压器过流损坏的事故起到一定的预防作用。

此保护开关优点解决了市场上多种开关高压断相（跌落开关掉闸）不起作用的难题。不论是高压跌落开关掉闸，低压保险烧坏，电动三相绕组一相不通点电造成缺相运行都能可靠的起到保护作用。

Our DZ15LED^{10-40A}_{50-100A}/^{100-250A}/3902 type multifunctional auto protective switch is mixed with the protection functions of phase failure, over-current, short circuit faults, able to provide the automatic protection for the motors under AC 380V, 50Hz, also used to start motor non-frequently, further to some degree, prevent the accident of distribution transformer destroyed resulted from over-current because motors run at failure of one phase caused one phase of drop out fuse melted down.

The merit of this switch has solved the problem that many switches can't take action while the one phase of drop out fuse is melted down, no matter drop out fuse melted down, low voltage fuse burnt, one phase of three phase motor is broken, which make it run at phase absence, it can perform the effective protection.

型号及其含义 Code and implication

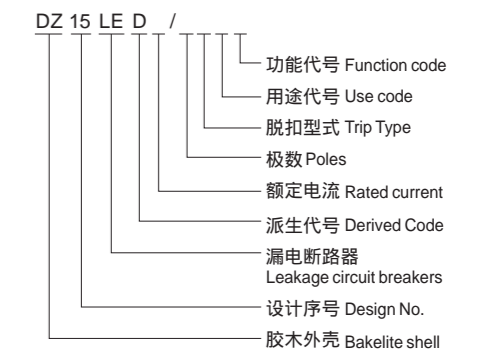

正常工作条件 Normal operating conditions

- 海拔高度不超过2500米；
- 没有雨雪侵蚀的地方；
- 无爆炸危险的介质中并且无腐蚀和破坏绝缘的气体与导电尘埃的地方。
- Altitude: not higher than 2500m
- No place rain and snow erosion;
- No explosive medium and no corrosion and damage the insulation of gas and conductive dust areas.

DZ20L 系列漏电断路器 Series Earth Leakage Circuit Breaker

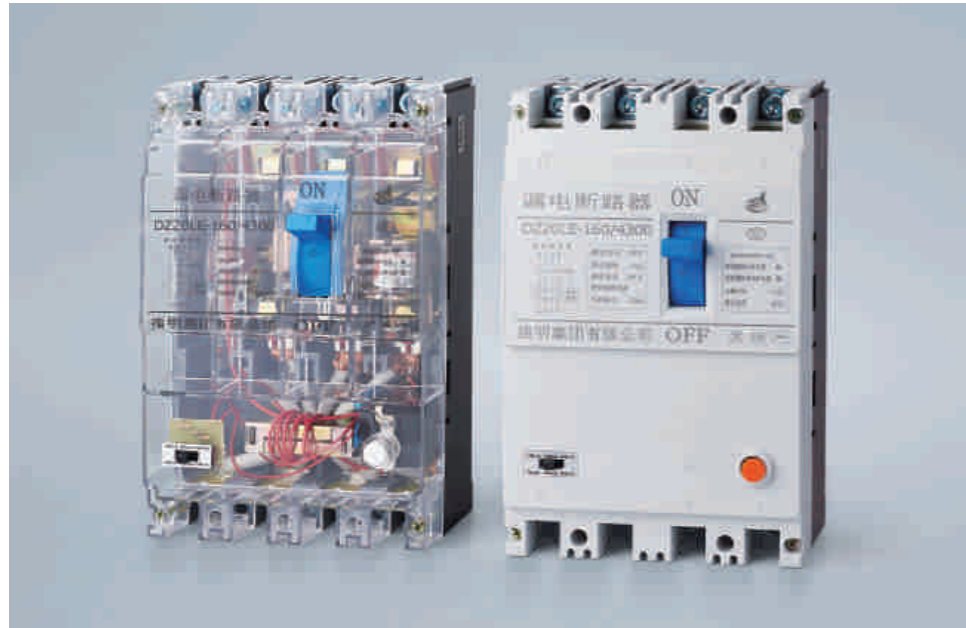

主要技术参数 Main Technical data

漏电断路器的主要技术参数

Main technical parameters of circuit breaker

型号 Type	额定电流 In(A) Rated current	额定工作 电压Un V Rated Working Voltage	额定极限短 路分断能力 Icu kA Rated Ultimate short-circuit breaking capability	额定剩余接 通和分断能力 I m kA Rated residual making and breaking capability	飞弧距离 mm Flashover distance	额定剩余 动作电流 I n mA Rated residual action current	额定剩余 不动作电 流 I no mA Rated residual non-action current	最大分断时间s Max breaking time s											
								一般型 Ordinary type						延时型 Time delay type					
								I n	2I n	5I n	I n	2I n	5I n	10I n					
DZ20L-160	50,63,80, 100,125,160	380	12	3	60	50	25	0.2	0.1	0.04	0.7	0.5	0.3	0.25	0.25				
DZ20L-250	125,160 180,200 225,250					15	4									100	50		
DZ20L-400	200,250 315,350 400		20	5	80	50	100	250	1.25	1	0.95	0.95							
DZ20L-630	315,350 400,500 630		30	6	100	500	250												

漏电断路器过电流脱扣器短路情况下的断开特性

型号 Type	配电保护用试验电流 Test current for distribution protection	保护电动机用试验电流 Test current for motor protection	整定值的准确度 Accuracy of setting value	约定时间s Conventional time	起始状态 Intiap state
DZ20L-160	10In	12In	± 20%	< 0.2脱扣 Trip	冷态 Cold state
DZ20L-250					
DZ20L-400					
DZ20L-630					

适用范围 Application

DZ20L系列漏电断路器(以下简称漏电断路器)主要适用于交流50Hz,额定工作电压为380V,额定电流至630A的配电网中,用来对人进行间接接触保护,也可用来防止因设备绝缘损坏,产生接地故障电流而引起的火灾危险,并可用来分配电能和保护线路及电源设备的过载和短路,还可作为线路的不频繁转换和电动机不频繁启动之用。

产品符合GB 14048.2和IEC 60947-2标准。

DZ20L series leakage circuit breaker (hereinafter referred to as leakage circuit breaker) is suitable for distributing network of AC 50Hz, rated working voltage 380V and rated current 630A, to make indirect contact protection to the human being, also to prevent fire accident caused by ground fault current due to the damage of insulation of equipment. In addition, it not only can distribute the energy and protect the circuit and power equipment against overload and short circuit, but also can be used to switch circuit and start the motor infrequently.

The products are in conformity with such standards as GB 14048.2 and IEC 60947-2.

3、配电用断路器反时限断开特性

Inverse time lag breaking characteristics of circuit breaker for distribution protection

试验电流名称 Name of test current	电流整定倍数 Current setting multiple	约定时间 T Conventional time				起始状态 Intiap state	基准温度 Ambient temperature
		1.01In	100A	63A < In	225A		
约定不脱扣电流 Conventional non-tripping current	1.05	1h		2h		冷态 Cold state	+30
约定脱扣电流 Conventional tripping current	1.30	< 1h		< 2h		热态 Hot state	
可返回时间 Returnable time	3.0	可返回时间 T Returnable time				冷态 Cold state	
		5s	8s	12s			

4、电动机保护用断路器反时限断开特性

Inverse time lag characteristics of circuit breaker for motor protection

试验电流名称 Name of test current	电流整定倍数 Current setting multiple	约定时间 T Conventional time	起始状态 Intiap state	基准温度 Ambient temperature
约定不脱扣电流 Conventional non-tripping current	1.00	2h	冷态 Cold state	+40
约定脱扣电流 Conventional tripping current	1.20	< 2h	热态 Hot state	
	1.50	4min	热态 Hot state	
返回特性电流 Returnable time	7.20	4s < 可返回时间 10s 4s < Returnable time 10s	冷态 Cold state	

外形及安装尺寸 Outline & installation size

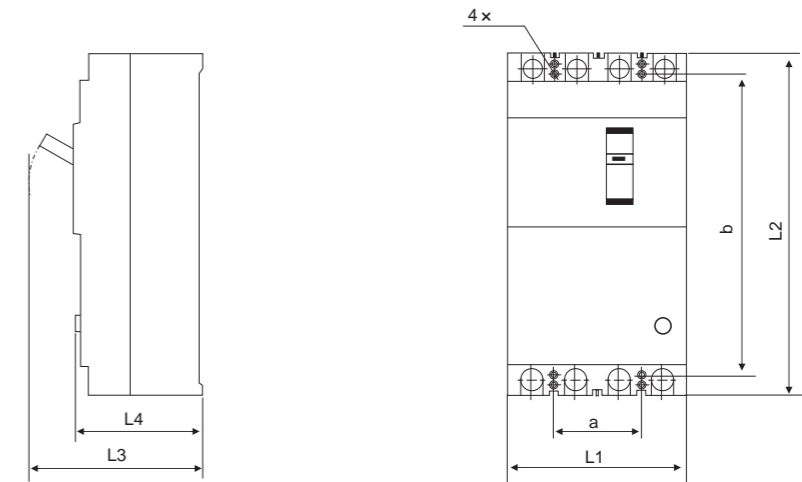

型号 Type	极数 Pole	外形尺寸 Outline size				安装尺寸 installation size		
		L1	L2	L3	L4	a	b	d
DZ20L-160	3	108 ± 1.75	225 ± 2.3	105 ± 1.75	90 ± 1.75	35 ± 0.31	204 ± 0.57	4.3~ 4.6
	4	143 ± 2.0	225 ± 2.3	105 ± 1.75	90 ± 1.75	70 ± 0.37	204 ± 0.57	4.3~ 4.6
DZ20L-250	3	109 ± 1.75	276 ± 2.6	143 ± 2.0	143 ± 2.0	35 ± 0.31	240 ± 0.65	4.3~ 4.6
	4	144 ± 2.0	276 ± 2.6	143 ± 2.0	143 ± 2.0	70 ± 0.37	240 ± 0.65	4.3~ 4.6
DZ20L-400	3	155 ± 2.0	360 ± 2.85	150 ± 2.0	150 ± 2.0	51 ± 0.37	324 ± 0.70	7~ 7.3
	4	206 ± 2.3	360 ± 2.85	150 ± 2.0	150 ± 2.0	102 ± 0.43	324 ± 0.70	7~ 7.3
DZ20L-630	3	155 ± 2.3	360 ± 2.85	150 ± 2.0	150 ± 2.0	70 ± 0.37	300 ± 0.70	7~ 7.3
	4	206 ± 2.6	360 ± 2.85	150 ± 2.0	150 ± 2.0	140 ± 0.43	300 ± 0.70	7~ 7.3

JD6- 鉴相鉴幅剩余电流保护器

Phase and amplitude discrimination residual current-operated protective device



功能特点 Function characteristic

- 分断时间分类为S型，分断时间0.5/0.3s两档可调。在2I_n、5I_n分段时间呈反时限特性。
- 设置多种接线类别(见型号说明)，可配接多种类别的主开关，互感器通用。
- 除接线类别为D或用户特别要求外，开机或停机后来电，有试送电一次，保护器分闸20~30秒后自动重合闸投入运行；如果在重合闸后5秒内再次跳闸，保护器则自锁。
- 剩余电流动作值固定分档可调，用户可根据线路状况或天气环境等情况选择适当的动作值。表面有电流显示线路总的剩余电流矢量值。
- 标准型对接的交流接触器有节能无声运行工作，接触器线圈220V、380V通用，接线方便，可延长接触器线圈寿命。有节能效果，1至2年的节电费就可以收回投资。
- The breaking time is classified as type S, has two adjustable gears: 0.5s and 0.3s. In the breaking time of 2I_n and 5I_n, it presents the inverse time lag characteristics.
- Many connection class may be set (see model description), main switches of various classes are available to be connected, and the transformers are generally accepted.
- Except the connection class D or user's special requirement, the trial power supply is performed once after startup or shutdown, the protection device recloses automatically after opening 20-30s and then puts into use; if the protective device trips again within 5s after reclosing, it is locked by itself.
- The fixed gear of residual current operation value is adjustable, user can select the proper operation value according to the circuit or weather conditions. The surface has the indication of total residual current vector value of circuit.
- The standard type protective device can make AC contactor work without noise and save the energy, the contactor coils of 220V and 380V are generally accepted, it is very convenient to connect, the service life of contactor coil maybe prolonged. Due to the energy-saving efficiency, the investments for electricity expense of 1-2 years may be recovered.

主要技术参数 Main Technical data

- 额定电压 380V
- 额定频率 50Hz
- 额定主电路电流 63A~400A
- 额定剩余电流动作值 0.1A、0.3A、0.5A可调
- 额定剩余电流不动作值 0.05A、0.15A、0.25A
- 额定分断时间 < 0.3s(0.5s)可调
- 额定辅助电压 220V
- 保护器输出接点容量 220V 3A
- 延时重合闸 20s ~ 30s
- 动作特性分类 AC型
- 分断时间分类 S型
- 熔丝容量(配接主开关大小不同) 5A、8A、10A
- Rated voltage 380V
- Rated frequency 50Hz
- Rated main circuit current 63A~400A
- Rated residual current operating value: 0.1A, 0.3A and 0.5A adjustable
- Rated residual current non-operating value: 0.05A, 0.15A and 0.25A
- Rated breaking time: < 0.3s(0.5s) adjustable
- Rated auxiliary voltage 220V
- Capacity of protection device output contact 220V 3A
- Delaying time of reclosing operation 20s ~ 30s
- Classification of operation characteristics: Type AC
- Classification of breaking time: Type S
- Fuse capacity (depending on the size of main switch): 5A, 8A and 10A

适用范围 Application

JD6 - 剩余电流(以下简称保护器)与低压断路器或交流接触器组合成剩余电流保护器装置。用来线路进行接地故障保护，防止由于接地故障电流引起的设备事故或电气火灾，可用来对人身触电危险提供间接接触保护，适合于配电网安全运行能力。

JD6 - 是本企业研究开发的新产品，采用单片微机控制技术，具有反时限功能，具有较理想的延时特性，分断时间有0.5/0.3s两档，任用户选调，并有一次重合闸功能。适应各种复杂的农村电网和多变的气候环境，投运率高，特别适用于电网多级保护中的一级总保护或二级总保护，产品符合DL/T499-2001农村电力技术规程对分断时间的级差要求。

JD6- phase and amplitude discrimination residual current-operated protective device (hereinafter referred to as protective device) combines with the low voltage circuit breaker or AC contactor to form the residual current operated protective device, it is used to protect the circuit against the earthing fault, prevent the equipment accident or electric fire for the earthing fault current, provide the indirect contact protection against the human electric shock, suitable for the safe operation of power grid.

JD6- protective device is our newly developed product, designed with the SCM control technology. It has functions like inverse time lag and primary reclosing functions as well as ideal time-delay characteristics, providing two gears of breaking time: 0.5s and 0.3s for user's selection. It is suitable for complex rural power grid and changeable climatic environment, with high rate of putting into use, especially, it is used for the primary general protection or secondary general protection of multi-class protection of power grid. The product has conformed to the requirements of breaking time class difference stipulated as DL/T4992001 Rural low-voltage Electric Power Technical Code.

ZMM20LE 剩余电流动作断路器 Residual Current Operated Circuit Breaker



适用范围 Application

ZMM20LE剩余电流动作断路器适用于三相/单相，中性点直接接地(TT)系统的低压电网系统，用来对线路或用电设备的接地故障、过电流、短路、过电压、欠电压、断电自动跳闸及缺相等进行保护，也可对人身触电危险提供间接接触保护。产品符合标准：GB14048.2, DL/T20..剩余电流保护器通信规约

ZMM20LE residual current circuit breaker is suitable for 3P/1P, low voltage distribution system which neutral point (TT) is earthed directly, used to protect against earthing fault, over-current, short circuit, over voltage, under voltage, auto tripping if power off, power failure and etc, also it can provide the indirect protection against electric shock for personnel. The product complies with GB14048.2, DL/T20 "Residual current circuit breaker"

主要功能和特点 Main functions and features

- 数码显示电流、电压及漏电流。
- 具有剩余电流自动跟踪、突变、特波、过载、过压、欠压、缺相、漏电保护功能。
- 可通过按键调节剩余电流报警、自动跟踪、突变、特波、自动重合闸、过压、欠压、缺相、全失压、过载保护等功能。
- 可通过按键查询，跳闸原因、次数及发生时间。
- 可通过试验按键实现现场试验跳闸控制。
- 可通过远程预约分闸、合闸、及试跳，以及预约取消控制功能。
- RS485通信功能，实现远程预约分闸，合闸，及试跳，以及预约取消控制功能。
- LED display current, voltage, leakage current
- Auto track residual current, protections against transient change, short circuit, overload, over voltage, under voltage, phase failure, electric leakage
- Able to adjust the warning value of residual current, the setting values of auto tracking, transient change, short circuit, auto reclosing, over voltage, under voltage, phase failure, voltage lost, overload and etc
- Seek the tripping reason, times, and occurrence time through pushbutton
- Push test button on the product to test the tripping operation
- Perform the remote tripping, closing, or test tripping at specified time, and cancel the operation at specified time
- RS485 communication function, to perform the remote tripping, closing, or test tripping at specified time, and cancel the operation at specified time

正常工作条件 Normal service conditions

- 环境温度：-5°C~+55°C
- 相对湿度：当空气湿度最湿月的平均最低温度不超过25°C时，该月的月平均最大相对湿度不超过90%，并考虑到因温度变化发生在产品表面上的凝露；
- 海拔高度：安装地点的海拔不超过2000m。
- 安装类别：Ⅲ级。
- 污染等级：2级。
- 安装条件：安装场所的外磁场任何方向均不应超过地磁场的5倍；
- Ambient air temperature: -5°C~+55°C
- When the ambient air temperature is +25°C, the relative humidity of the air shall not be higher than 90%; a higher relative humidity is allowed at a lower temperature; special measures shall be taken for the condensation occasionally produced due to temperature change.
- Altitude: not higher than 2000m for the installation site.
- Installation category: III grade.
- Pollution degree: 2.
- Installation conditions: external magnetic field in any direction installation site should not exceed five times the Earth's magnetic field;

ZMM20LE

剩余电流动作断路器

Residual Current Operated Circuit Breaker

主要技术参数 Main Technical data

额定电压Ue(V) Rated Voltage	400V
额定电流In(A) Rated current	63,80,100,125,160,200,250,315,350,400,630,700,800A
额定绝缘电压Ui(V) Rated insulation Voltage	800V
额定辅助电源电压 Rated auxiliary supply voltage	220V
突变漏电动作值 Sudden leakage action value	50mA(可调Adjustable)
额定剩余电流动作值 Rated residual current action value	75/150/300/500mA(可调Adjustable)
额定极限不驱动时间 Rated limit no drive time	60/200/300ms(可调Adjustable)
重合闸延时时间 Reclosing delay time	20-60s
动作特性类别 Action characteristics category	AC型
分断时间分类 Breaking time classification	S型, 延时型(可调Adjustable)

外接端子说明 External Terminal Description

6,7脚为RS485通信接口;其余1、2、3、4、5脚目前为空。外接端子如图所示

6,7 feet for the RS485 communication interface; the remaining 1,2,3,4,5 feet are currently empty/External terminals as shown

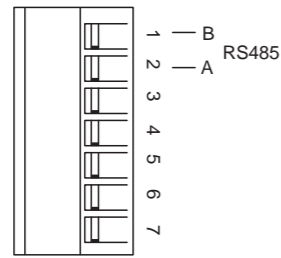

外接端子
External terminal

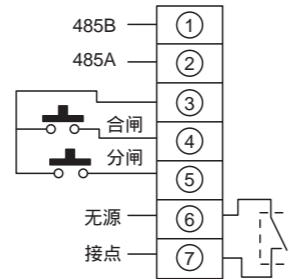

外接按钮分合闸接线图
Wiring diagram of external switch

外形及安装尺寸 Outline & installation size

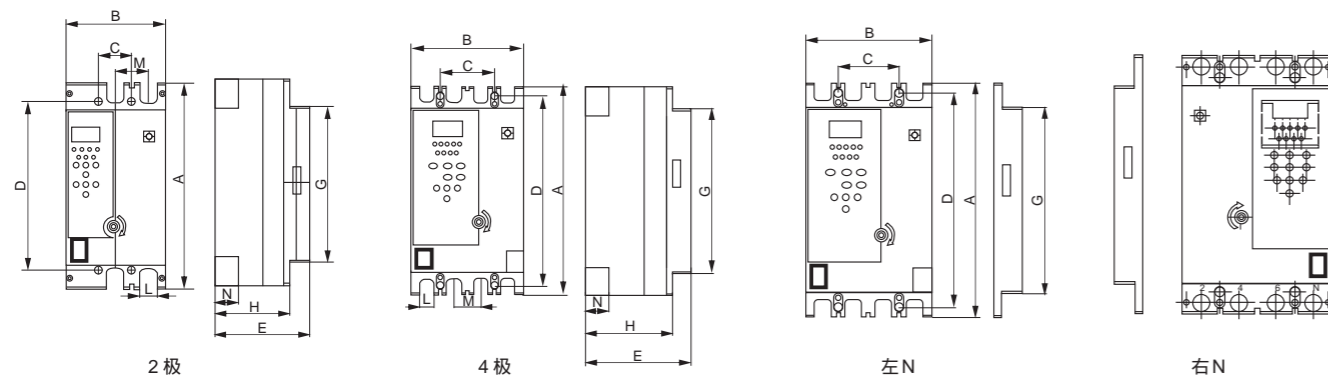

型号 Type	外形尺寸 Outline size					安装尺寸 installation size					
	A	B	E	H	G	C	D	孔径	M	L	N
ZMM20LE-125-2P-A	215	105	87.5	65	171.5	24.9	195.8	Ø4.5	24.9	16	23
ZMM20LE-125-2P-H	134	120	104	77	134	26	116	Ø4.5	24.9	16	23
ZMM20LE-250-2级	215	105	98	77	162	34.9	175.6	Ø4.5	34.9	24	24
ZMM20LE-125-4级	230.5	126	98.5	78	182.4	60	210.7	Ø4.5	30	20	24.8
ZMM20LE-250-4级	240	142.2	98.5	78	185	69.7	200.8	Ø5.5	34.9	24	24.5
ZMM20LE-400-4级	336.8	195.6	178.4	129.5	254	95	271	Ø5.5	44	32	35
ZMM20LE-800-4级	359	281	178.4	129.5	253	140	271	Ø5.5	70	48	35

ZMKBO

系列控制与保护开关电器 - 基本型

Series control and protective switching device - basic type



产品特点 Product features

- 采用高效新型进口单片机进行数据采集和数据处理, 实现自动控制; 对所需要保护的设备能够做到保护全面, 控制精确;
- 能实现三段保护(过载长延时、短路短延时和瞬时); 过载长延时保护可根据客户的需要设定为定时限或反时限, 短路短延时和瞬时保护为定时限;
- ZMKBO系列产品参数设置齐全且直观, 保护功能稳定可靠, 并可根据用户的需求打开调整某些参数或关闭某些功能等;
- 克服了一般开关电器使用类别单一的缺陷, 只要满足一定的条件就能在多种使用类别下正常使用; 特别是克服了由于采用不同考核标准的电器;
- 产品之间组合在一起时, 保护特性与控制特性配合不协调的现象, 极大地提高了控制与保护系统的运行可靠性和运行连续性的性能;
- 开关工作特性可靠性高, 具有机械联锁和电气联锁, 保证了ZMKBO产品的高可靠性。
- 与分离电器构成的系统对比;
- ZMKBO系列控制与保护开关电器产品集控制与保护功能于一体, 相当于“断路器(熔断器)+接触器+热断路器+辅助触头”, 很好的解决了分离器件较难解决的器件之间控制与保护特性匹配问题。使控制与保护特性匹配完善合理(具有过载长延时、短路短延时和瞬时三段保护特性), 只要根据负载功率或电流即可正确选择单一产品, 减轻了工程设计人员的工作量。由ZMKBO构成的系统具有运行可靠性高, 连续运行性能好, 额定运行短路分断能力ICS(50kA/380V)高, 飞弧距离小(30mm)特点;
- 运行可靠性高: 因为ZMKBO额定运行短路分断能力ICS高, 飞弧距离小等特点。在分断短路电流后(短路电流需在额定ICS以内), 无需维护即可投入使用(若有短路故障需排除短路故障, 否则会再次分断且会影响产品使用寿命)。提高了系统的运行可靠性和连续运行性能。

- Adopted foreign advanced SCM to acquisition and process data, perform automatic control, protecting equipment where necessary.
- It can perform three-stage protections (overload long delay, short circuit short delay, and instantaneous trip); overload long delay protection can be set as definite time limit or inverse time limit type, short circuit short delay and instantaneous protections are definite time limit type.
- ZMKBO series products have full parameter settings and legible, stable and reliable protection, some parameters can be adjusted or some function can be closed according to user requirement.
- It does not like common CPS which usage scope/application is very limited, once some conditions is complied, our CPS can operate in many conditions, specially overcome the limit of those places that it shall compliance with different standards.

适用范围 Application

ZMKBO系列控制与保护开关电器适用于交流电压至690V/50Hz(60Hz), 额定电流自0.25A至125A的电力系统中, 能够接通, 承载和分断正常条件下包括规定的运行过载条件下的电流, 且能接通, 承载和分断规定的非正常条件下的电流, 如短路电流。广泛应用于建筑、通讯设备、纺织、冶金、石化、水利工程、水处理、机械装备、成套设备、船舶、食品加工及电动机控制中心等领域。

如果负载(如电动机)大小的发生了变化, 可在空载的情况下重新设置好参数如额定电流(只能在主体额定电流范围0.4~1Ie内调整), 起动电流倍数及起动延时时间等, 就能起到很好的保护功能作用。使用ZMKBO开关电器的适用范围拓宽, 以适应大小不同的负载, 且保护功能不受影响。

ZMKBO series control and protective switch is operating in the power system of AC voltage up to 690V/50Hz (60Hz), rated current from 0.25A to 125A, able to make, carry, and break the specified overloading current at normal conditions, and make, carry, and break some current at abnormal conditions, such as short circuit current, widely used in construction, communication, equipment, textile, metallurgy, petrochemical, water hydro project, water treatment, machinery, complete set, vessel, food processing and motor control center and etc.

If load (such as motor) has changed, it can readjust the parameters such as rated current at no-load (It can be adjusted when the main circuit pass rated current 0.4~1 Ie), times of startup current, startup delay time and etc, so it can take good action to protect the load. ZMKBO CPS has wide application range, suitable for large or small load, protection function is not influenced.

ZMKBO

系列控制与保护开关电器

Series control and protective switching device



- When the products cooperated together, the good coordination relationship between protective characteristics and control characteristics can improve the reliable and continuous control and protection for the system.
- High reliability, with mechanical and electrical interlocks, it ensures safety and stableness.
- Compared with the system with similar use formed by some separate devices:
- ZMKBO series CPS integrated with control and protection function, equivalent to the combination of breaker (fuse) + contactor + thermal relay + auxiliary contacts, our CPS has solved the problem that it is difficult to cooperate between separate devices in the control and protection characteristics for the separate system. This control and protection characteristics is well matched (overload long delay, short circuit short time delay, and instantaneous, three-stage protections), we can easily choose the right CPS according load power or current, saving the job of technician design. The system installed with ZMKBO is more reliable, higher continuity, high rated short circuit capacity Ics (50KA/380V, short arcing distance (<30mm));
- High reliable operation, due to high rated short circuit capacity Ics, short arcing distance, after the CPS break short circuit current (it shall within specified Ics), it can be put into service again without maintenance (it shall eliminate the short circuit fault, or it will break again and have influence on the servicing life), well improve operation reliability and continuity.

快速选型图 Model fast selection

Z M K B O 1 0 0 / M 1 0 0 / 0 6 M F G
 ↓ ↓ ↓ ↓ ↓ ↓ ↓ ↓ ↓ ↓ ↓ ↓

企业代号 Enterprise symbol	控制与保护开关电器 Control and protective switching device
壳架等级电流 Rated frame current Inm : 45 , 100(125)	
组合型式代号 漏电—L ; 双电源—S ; 星三角—J ; 减压启动—J2 ; 可逆双向—N ; 双速电机—D ; 三速电机—D3 Combination codes: Leakage-L, twin power source-S, Star-delta-J; voltage reduction startup-J2; Reversible bi-directional-N; Dual speed motor- D; Triple motor-D3	
极数 Pole number 33 : 3极带3极保护可省略不写 33: 3P with 3 pole protected, allowed to omit writing 43 : 4极带3极保护 ; 44 : 4极带4极保护 43: 4P with 3poles protected; 44: 4P with 4P protected.	
电子过载脱扣器类别代码 Category code of electronic overloading release M : 电动机保护(起动电流倍数) M: Motor protection (times of startup current) L : 配电保护(起动电流倍数可调) L: Distribution type: (Times of startup current, adjustable)	
额定电流 Rated current	
附件组合代号 Accessories combination code 02 : 二常开+一常闭+(一常开故障+一常开短路) 02: 2NO+1NC +(1NO for fault +1 NO for short circuit) 06 : 三常开+二常闭+(一常开故障+一常开短路) 06: 3NO+2NC + (1NO for fault +1 NO for short circuit) 09 : 四常开+三常闭+(一常开故障+一常开短路) 09: 4NO+3NC + (1NO for fault +1 NO for short circuit)	
线圈控制电源电压 : M : AC230V ; Q : AC380V Voltage of control coil: M : AC230V ; Q : AC380V	
派生代号 Reproduction code 基本型 : 无 ; 消防 : F ; 隔离 : G Basic type: no code; fire fighting type: F; for isolation: G 以上代号可以任意组合 The above codes can be combined at random	

正常工作条件和安装条件 Normal working and mounting conditions

- 周围空气温度 : 下限为-5 , 上限不超过+40 , 且24h内的平均温度不超过+35 ;
- 安装地点 : 海拔不超过2000M ;
- 湿度 : 在最高温度为+40 时, 空气的相对湿度不超过50%, 在较低的温度下可以允许有较高的相对湿度, 如在20 时达90%。对于温度变化偶尔产生的凝露应采取特殊的措施 ;
- 污染等级 : 环境条件为污染等级3 ;
- 安装类别 : 类 ;
- 安装地点无明显冲击振动和无雨雪侵袭, 上接线端子为电源侧, 下接线端子为负载侧, 建议与地面垂直安装。
- Ambient temperature not lower than -5 , not higher than 40 , average per 24h not exceed +35 ;
- Mounting altitude not exceed 2000M
- Humidity: at highest temperature 40 , relative humidity not more than 50%, at lower temperature, higher humidity allowed, for example, at 20 , 90% allowed, it shall take special treatment if there has dew resulted from temperature change.
- Pollution grade: 3
- Mounting category III
- Mounting site shall have no obvious vibration, rain and snow not accessible, upper wire terminals are power source input, downside terminals are for load side. We recommended you of mounting vertical to ground.

外形及安装尺寸 Outline and mounting sizes

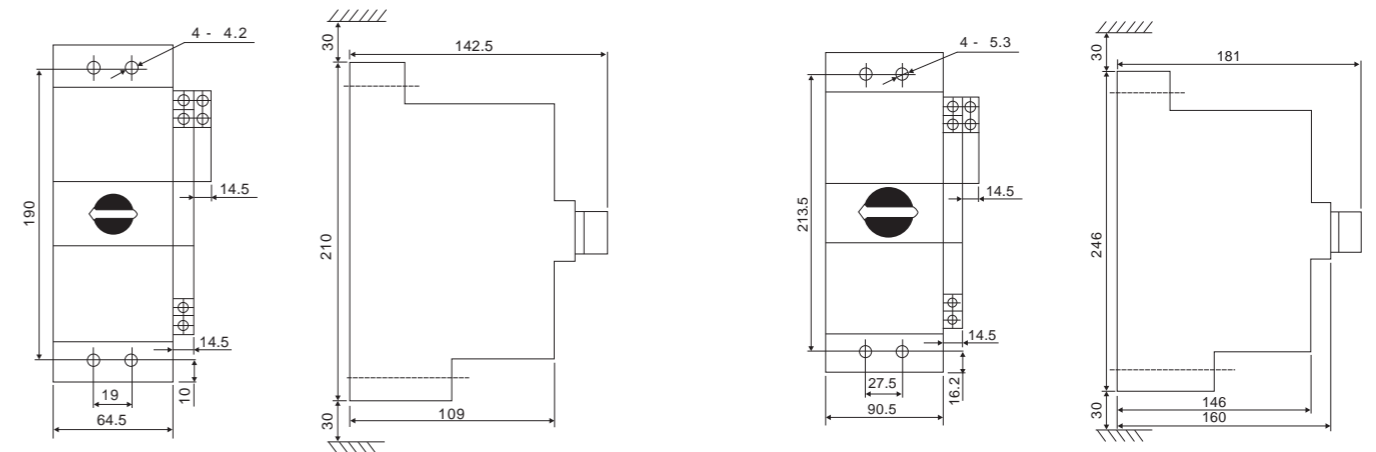

ZMKBO-45三极外形及安装尺寸 单位 : mm

ZMKBO-125三极外形及安装尺寸 单位 : mm

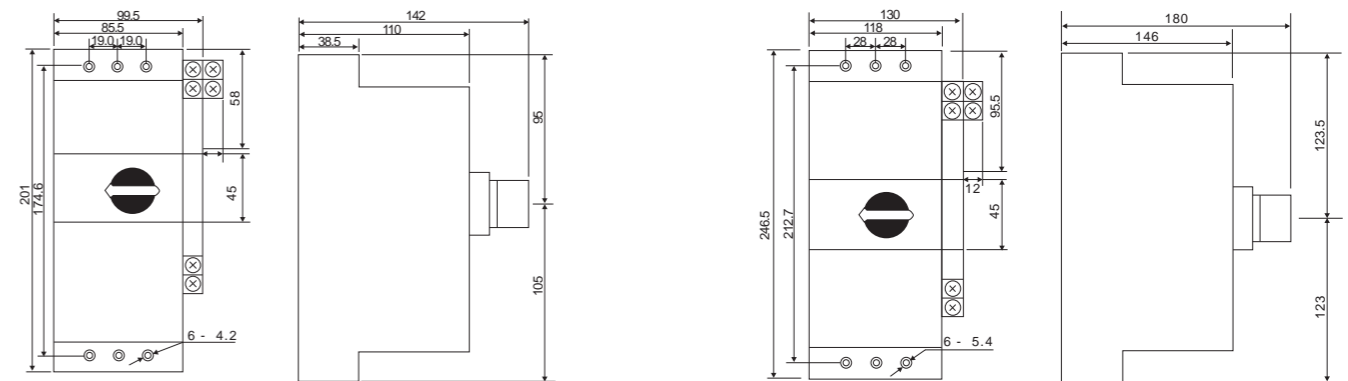

ZMKBO-45四极外形及安装尺寸 单位 : mm

ZMKBO-125四极外形及安装尺寸 单位 : mm

ZMKBO

系列控制与保护开关电器

Series control and protective switching device

ZMKBO-J 星三角型减压启动器
ZMKBO-J Star-delta voltage reduction starter

单位为毫米

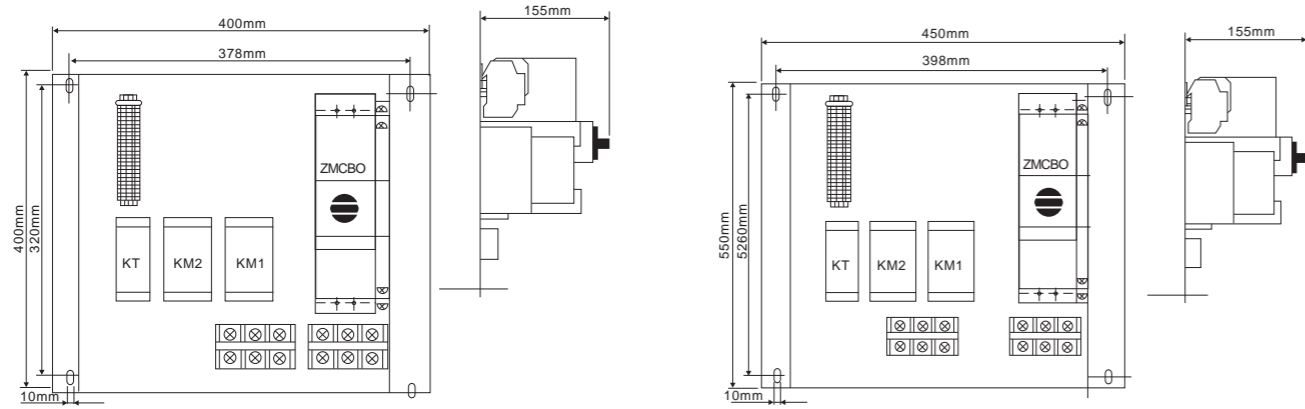

ZMKBO-J-45星三角型减压启动器成套单元

ZMKBO-J-125星三角型减压启动器成套单元

ZMKBO-D双速电动机控制器
ZMKBO-D Dual speed motor controller

单位为毫米

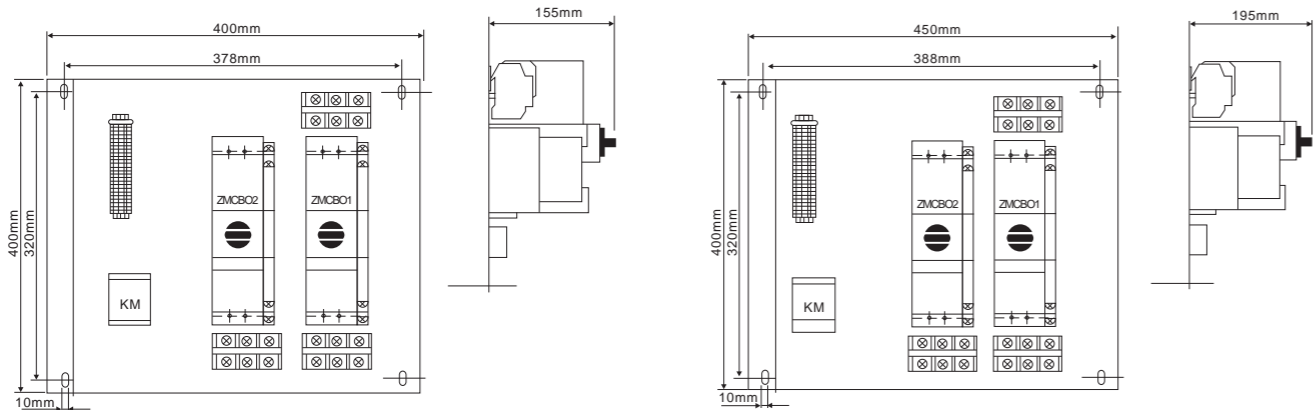

ZMKBO-D-45双速电动机控制器成套单元

ZMKBO-D-125双速电动机控制器成套单元

ZMKBO-N可逆(双向)电动机控制器
ZMKBO - N reversible (bi-directional) motor controller

单位为毫米

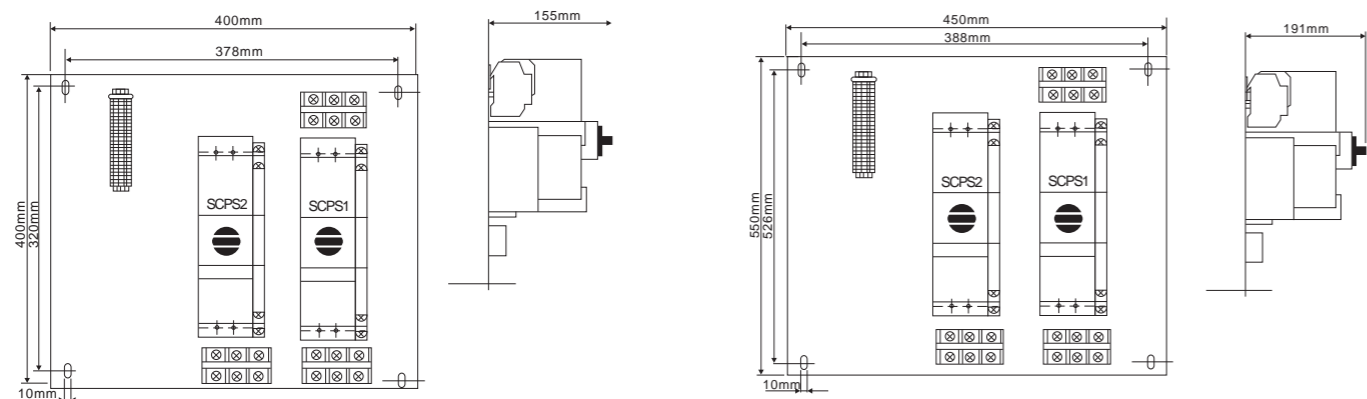

ZMKBO-N-45可逆(双向)型控制与保护开关电器

ZMKBO-N-125可逆(双向)型控制与保护开关电器

ZMQ2E

系列双电源自动转换开关

Series twin power source auto transfer switch (ATS)

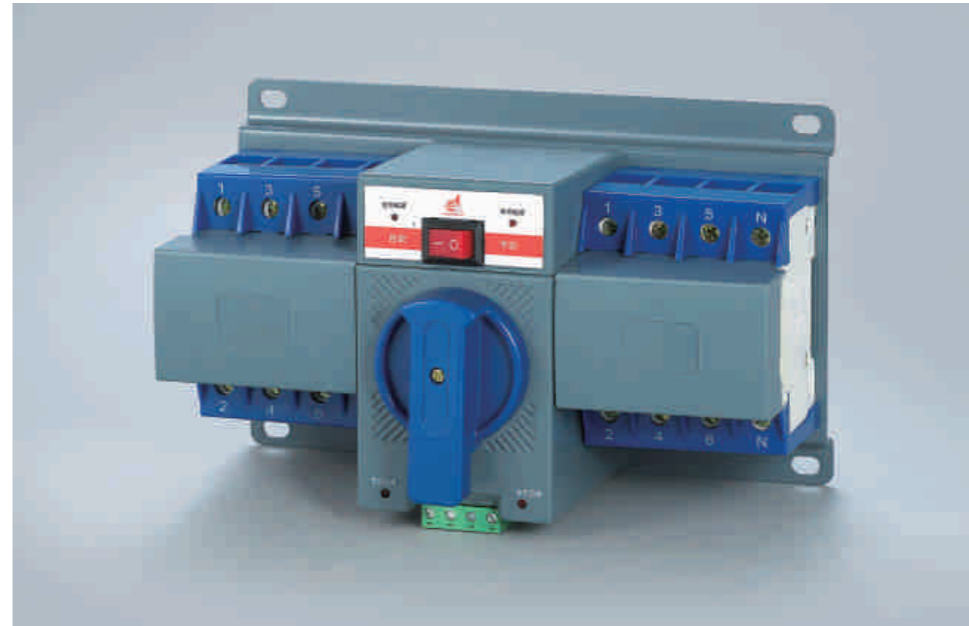

适用范围 Application

ZMQ2E双电源自动转换开关(以下简称双电源),它适用于交流50Hz、额定工作电压400V、额定工作电流63A及以下的供电系统。可根据需求进行两路电源之间的选择转换。产品具有过载、短路、欠电压保护功能,同时还具备消防、双分和输出合闸信号功能。特别适用于需要消防需求的写字楼、商场、银行、高层建筑等的照明线路用。

本产品符合GB/T14048.11标准。

ZMQ2E Twin power auto transfer switch (hereinafter called ATS), is suitable for operating in the power system of AC50Hz, rated operating voltage 400V, rated current 63A and below, to perform the shift between two power supply according to the requirement. The product has the protection functions of overload, short circuit, under-voltage and etc, meanwhile provides firefighting, dual OFF and output the signal of closing. It is especially suitable for the illuminating circuits of commercial building, marketplace, bank, high buildings where need firefighting function.

型号及含义 Type and meaning

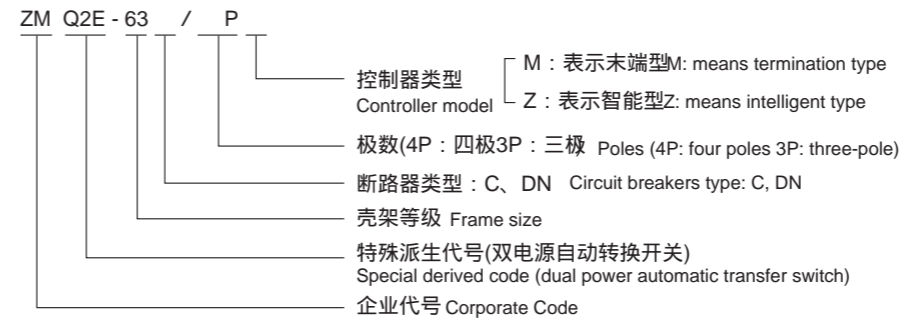

正常工作条件 Normal working condition

- 安装地点的海拔不超过2000m。
- 周围空气温度: 周围空气温度上限不超过+40; 周围空气温度24h的平均值不超过+35; 周围空气温度下限不低于-5。
- 湿度: 最高温度为+40时, 空气的相对湿度不超过50%, 在较低的温度下可以允许有较高的相对湿度, 例如20时达90%, 对于湿度变化偶尔产生的凝露应采取特殊的措施。
- 污染等级: 3
- 安装条件: 安装在无冲击振动及无雨雪侵袭的地方; 上接线端子接电源侧, 下接线端子接负载侧; 与垂直面的倾斜度不超过5°。
- 安装类别:
- 安装场所附近的外磁场在任何方向不超过地磁场的5倍。
- Altitude: not higher than 2000m for the installation site.
- When the ambient air temperature is -5 ~ +40, the mean value is no greater than +35 with in 24 hours.
- Relative humidity not exceed 50% at the max temperature of +40, higher relative humidity is allowable under lower temperature. For example, RH could be 90% at +20, while special measures shall be taken for the condensation occasionally produced due to temperature change.
- Pollution degree: 3
- Mounting conditions: it shall be mounted on the place where has no impact, vibration, no access of snow and rain, upper terminal connected to power source, downside terminal connected to load side, the vertical sloping angle shall not exceed 5°
- Installation category: III
- The outer magnetic field around the mounting site shall not exceed 5 times of earth field

ZMQ2E

系列双电源自动转换开关

Series twin power source auto transfer switch (ATS)



结构与工作原理 Structure & Working theory

- 结构**
ZMQ2E双电源开关主要由两台微型断路器、电动机、控制器和机械转动装置组成。开关工作有三个状态位置供用户选择。常用电源合、双分、备用电源合。
采用高分断微型断路器，具有断路器分断能力与特性。
结构简单实用，操作方便具有无噪音，冲击力小，使用寿命长等优点。
- 工作原理**
双电源自动转换开关通过控制器对两路电源的检测，当一路电源发生异常时，控制器对检测结果作出逻辑判断，根据控制器指令驱动操作机构进行分闸或者合闸，从而保证对负载安全可靠的供电。

- Structure**
ZMQ2E Twin power auto transfer switch consists of two pieces of miniature circuit breaker, motor, controller, and driving mechanism. The ATS has three positions for user choice, normal power ON, dual OFF, standby power ON.
High breaking miniature circuit breaker is used, same performances.
Simple structure, practical, easy operation, no noise, small impact, long service life and etc.
- Working theory**
The controller of ATS will detect two loops of power supply, when one loop has fault, controller will give a logic decision and send a command of closing and opening the related miniature circuit, to ensure the safe and reliable power supply

主要技术参数 Main Technical data

- 双电源自动转换开关基本参数见表1 Main technical data of the ATS (see Table 1)

名称 Description	产品性能参数 Specifications	
符合标准 Complied standards	GB/T 14048.11	
ATS级别 ATS Electric Level	CB级	
使用类型 Use Category	AC-33iB	
额定工作电压Ue Rated operating voltage	AC220-400V	
额定工作频率 Rated operating frequency	50Hz/60Hz	
额定工作电流Ie Rated operating current	6A, 10A, 16A, 20A, 25A, 32A, 40A, 63A	
开关控制电压 Switching control voltage	AC220V	
额定绝缘电压Ui Rated insulation voltage	AC690V	
转换动作时间 Conversion action time	<3s(不可调节, 出厂已调整好)	
寿命 Endurance	电气寿命 Electrical endurance	1500次
	机械寿命 Mechanical endurance	6000次
额定短路接通能力Icm Rated short-circuit making capacity	7.5kA	
额定短路分断能力Icu Rated short-circuit breaking capacity	5kA	

- 双电源自动转换开关末端型和智能型基本参数见表2 Basic parameters of termination type and intelligent type twin power ATS as table 2

产品型号 Type	末端型 Terminal type	智能型 Intelligent type
安装方式 Installation	一体式 Integral type	
操作方式 Operation	自动和手动 Auto and Hand	自动、手动和双分 Auto, Hand and Dual OFF
监测功能 Monitoring	断相检测 Detection of phase failure	常用电源三相欠压、缺相和断相检测 Protections of three-phase under-voltage, phase absence, and phase failure detection
转换方式 Conversion	自投自复 Auto switch auto reset	
消防联动控制 Fire control	无 Unavailable	DC12-24V输入双分 (火灾自动切断功能) DC12-24V input dual points (fire automatic cut-off function)
显示功能 Display Function	信号指示功能 Indication of signal lamp	

开关外形及安装尺寸 ATS Dimensions

外形尺寸和安装尺寸符合表3及图1要求 Outline and mounting dimensions (see table 3 and figure 1)



图 Figure 1

型号规格 Type	外形尺寸 External dimensions			安装尺寸 Mounting Dimensions		
	L	W	H	L1	W1	d
四极开关 4-pole switch	220	132	120	200	120	4
三极开关 3-pole switch	185	132	120	165	120	4

表3 Table 3

安装 Installation

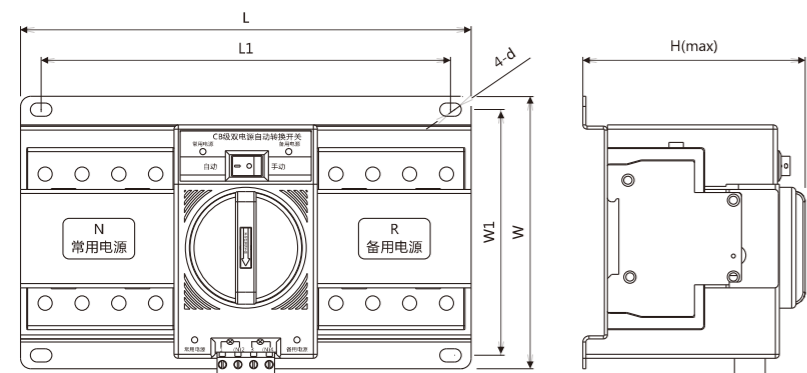
- 连接导线**
双电源用连接导线(电缆)采用单芯聚氯乙烯(PVC)绝缘铜导线或等效的铜排,截面积按表4选取。
- Connected conductor**
The used conductor for ATS is single core PVC insulated copper cable or equivalent copper busbar, the sectional cross area is determined according to table 4.

表4 Table 4

额定电流In (A) Rated Current	6	10	16 20	25	32	40 50	63
导线或铜排截面积mm ² Sectional cross area of conductor or copper busbar	1.0	1.5	2.5	4.0	6.0	10	16

- 双电源自动转换开关接线图 Wiring diagram of twin power ATS
四极开关接线见图2 Wiring diagram of 4-P circuit breaker as Figure 2



图 Figure 2

- 三极开关接线见图3 Wiring diagram of 3-P circuit breaker as Figure 3

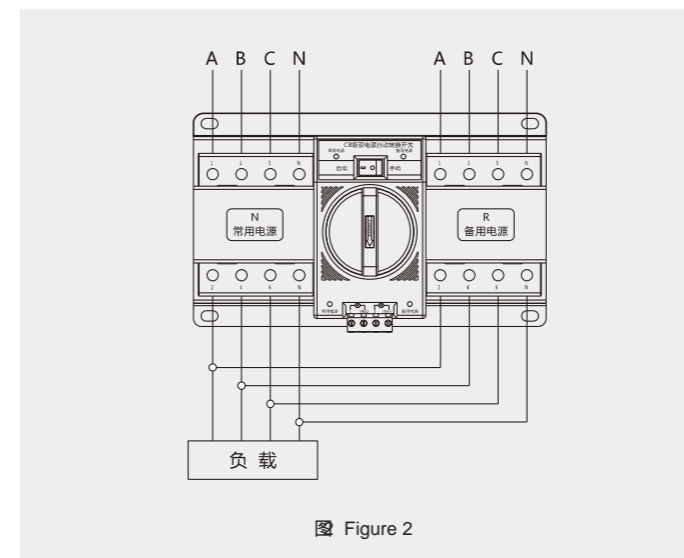

图 Figure 3

- 双电源自动转换开关输出端接线示意图
末端型输出端子接线示意图见图4
- Wiring illustration for output side of twin power ATS
Wiring illustration for output side of termination type ATS as Figure 4

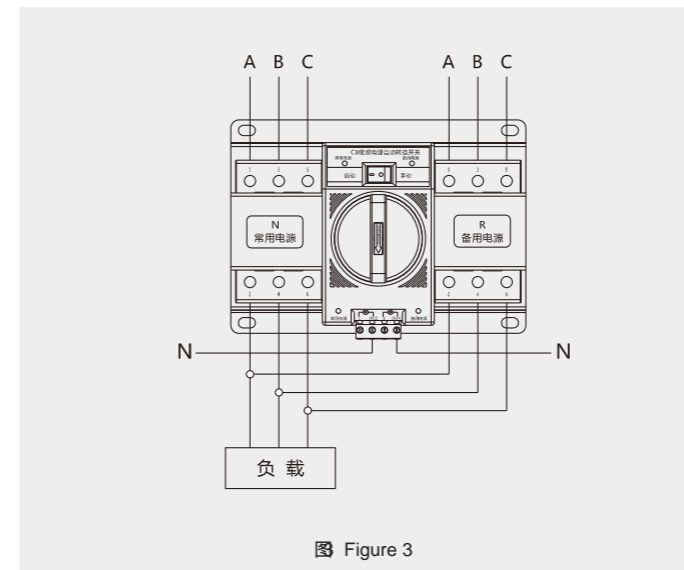

图 Figure 4

- 智能型输出端子接线示意图见图5
Wiring illustration for output side of intelligent type ATS as Figure 5

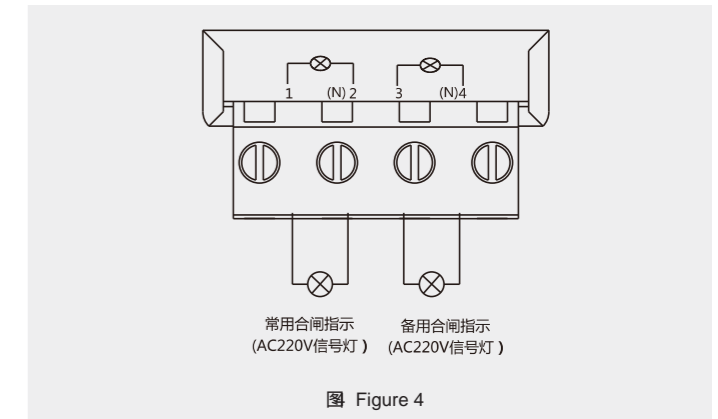

图 Figure 5

订货须知 Ordering Information

- 用户订货时必须说明:
- 双电源自动转换开关的名称及型号;
- 双电源自动转换开关的额定电流(A);
- 极数(四极, 客户未注明时产品为三相四线制);
- 双电源自动转换开关的控制器类型;
- 数量。
- 顾客对微型断路器的要求DZ47型或C65
- 例如: 订购双电源自动转换开关, 三极, 额定电流6A, 末端型, 数量50台。可写为: ZMQ2E-63/3P 6A 50台。
- 订购双电源自动转换开关, 四极, 额定电流63A, 智能型, 微型断路器需要C45D型要求数量50台。可写为: ZMQ2E-63/4PZ 63A C45D 50台。
- Please indicate when user to book the product:
- The name and model of twin power ATS
- Rated current of ATS (A)
- Number of poles (4Poles, if not indicate, the product will be 3 phase, 4wire)
- Controller model of ATS
- Qty.
- Selection of miniature circuit breaker such as DZ47 or C65 by user.
- For example: Book ATS, 3poles, rated current 6A, termination type, qty 50pcs, you can write: ZMQ2E-63/3P 6A 50pcs
- Book ATS, 4poles, rated current 63A, intelligent type, miniature circuit breaker shall be C45D, qty 50pcs, you can write: ZMQ2E-63/4PZ 63A C45D 50pcs

ZMQ2M

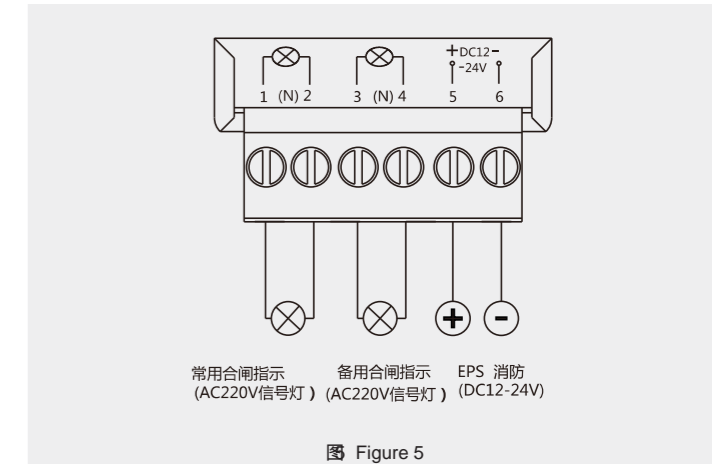
系列双电源自动转换开关

Series twin power source auto transfer switch (ATS)



型号及含义 Type and meaning

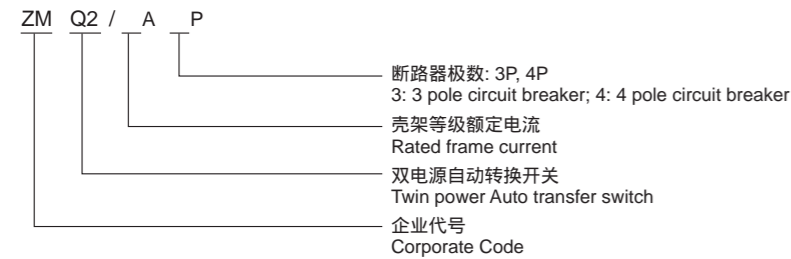

正常工作条件 Normal working condition

- 安装的海拔高度不超过2000米。
- 周围环境温度上限不高于+40℃，下限不低于-5℃，24小时平均值不超过+35℃。
- 大气的相对湿度在周围空气温度为+40℃时不超过50%，在较低的温度下，可以有较高的湿度，应考虑到湿度变化会发生产品表面的凝露。
- 无爆炸危险的介质，且介质无足以腐蚀和破坏绝缘的气体与尘埃。
- 无显著摇动和冲击震动的地方。
- The installation altitude not exceeding 2000 meters.
- The upper limit of the ambient temperature is not higher than +40°C, the lower limit of not less than -5°C, 24-hour average does not exceed +35°C.
- Atmospheric relative humidity in the ambient air temperature is +40°C not more than 50%, at lower temperatures can have a higher humidity, condensation products should take into account the surface of the humidity change.
- No explosive medium, the medium does not enough to corrode and damage the insulation of gas and dust.
- No significant shake and shock vibration.

适用范围 Application

自动电源切换开关（以下简称切换开关）适用于交流50Hz，额定工作电压380V、额定工作电流63A-225A双电源供电系统，用自动或手动操作方式完成常用电源与备用电源之间的切换。该切换开关主要用于医院、商店、银行、化工、冶金、高层建筑、军事设施等重要场合。

Automatic power switch (hereinafter referred to as switch) for AC 50Hz, rated working voltage 380V, rated current 63A-225A dual power supply system, with automatic or manual operation complete the handover common power supply and standby power supply. The switch is mainly used for important occasions, hospitals, shops, banks, chemical industry, metallurgy, high-rise buildings, military installations and so on.

基本结构 Basic structure

自动电源切换开关主要由电源转换执行断路器组成，开关工作有三个状态位置供用户选择：常用电源(N)合、双分、备用电源(R)合，开关具有体积小、重量轻、工作稳定，使用方便等。

Automatic power switch mainly by the power converter to perform circuit breaker composition, there are three state switching positions for users to choose: the common power supply (N) together, double points, standby power (R) together, the switch has a small size, light weight, stable easy to use and so on.

安装及使用方法 Installation and Use

接线时，常用电源N应接入常用电源执行断路器QN，备用电源R应接入备用电源执行断路器QR。当QN和QR为四线断路器时，接线方式按接线图，其中QN和QR的1、3、5为三相(A、B、C)进线端，2、4、6为三相出线端，7为零线(N)进线端，8为零线出线端。若选用断路器为三极断路器，则必须将常用电源(N)的零线NN和备用电源(R)的零线NR同时接到三极专用接零线端子KG上。具体操作见接线图。双电源切换开关自动控制器的电源取断路器QN和QR的进线端A相和零线N，若选用断路器为三极断路器时，必须要接零线NN和NR，该三极专用接零线端子在两台断路器中间，在自动电源切换开关安装，接线过程中，切不要把原接在断路器进线端的本机控制器线忘掉，碰断或短路等。

When wiring, commonly used power N should be connected to the common power supply execution breaker QN. Standby power R should be connected to the standby power to perform breaker QR. When QN and QR four-wire circuit breakers, wiring according to the wiring diagram in which the QN and QR 1,3,5 three-phase (A, B, C) into the line side, 2,4,6 three-phase outlet end, 7 zero line (N) into the line side. 8 zero line outlet end. If the selection of the circuit breaker for the three-pole circuit breaker, it must be the common power supply (N) of the zero line NN and standby power (R) NR also received zero line on the three-pole dedicated zero line terminals KG. For details, see wiring diagram. Dual power switch controller automatically take the power supply circuit breaker QN and QR end of the line A-phase and neutral N, if the choice of circuit breaker for the three-pole circuit breaker must be connected to the zero line NN and NR, the three-pole zero dedicated wiring terminals in the middle of two circuit breakers, the automatic power switch installation, wiring process, not to cut into the line circuit breakers connected to the original end of the line controller forget, touch off or short circuit.

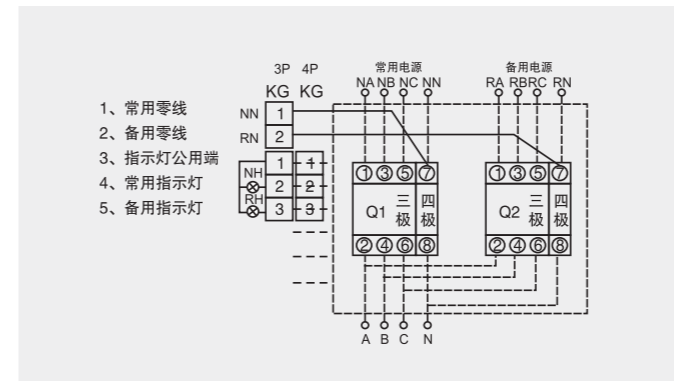

使用操作 Using the Operation

无论常用电源和备用电源有无电压，均可采用手动操作方式。手动操作时，应将手动-自动按钮置于手动操作位置，当推动手柄顺时针旋转至终端时，备用电源执行断路器QR分闸，常用电源执行断路器QN合闸；当推动手柄逆时针旋转至终端时，备用电源执行断路器QR合闸，常用电源执行断路器QN分闸。

面板中，电源指示灯（红），若该灯不亮，说明自动控制盒工作电源有故障，不能操作开关。待恢复正常后，将手动-自动按钮置于自动位置状态，如果常用电源供电正常，切换开关将自动投入常用电源执行断路器QN合闸状态，面板中N指示灯（黄）亮；如果常用电源供电不正常，则切换开关将自动换到备用电源QR供电，备用电源R指示灯（绿）亮。

Regardless of whether the common power supply and standby power supply voltage, and can be manually operated. In manual operation, the manual should be an automatic button in manual operation position when rotating the handle clockwise to push the terminal, perform backup power circuit breaker QR opening, common power supply execution breaker QN closing; when the push handle is rotated counterclockwise to the terminal, perform backup power circuit breaker QR closing, the common power supply execution breaker QN opening.

Panel power indicator (red), if the lamp is not lit, indicating the automatic control box Power supply failure, the switch can not be operated. After repaired properly, a manual Auto button in the automatic position state, if the common power supply is normal, the switch will be automatically put into the implementation of the common power supply circuit breaker QN closing state, the power indicator panel N (yellow) light; if common power supply is not normal, the switch will automatically switch to standby power supply QR, R standby power indicator (green) light.

外形及安装尺寸 ATS Dimensions

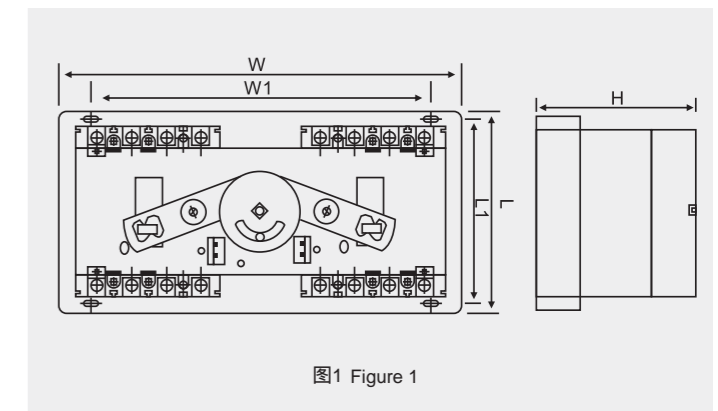

规格 Type	尺寸 Dimension	W	W1	L	L1	H
ZMQ2M 100/3P		290	254	207	188	120
ZMQ2M 100/4P		320	282	207	188	136
ZMQ2M 225/3P		332	290	216	195	140
ZMQ2M 225/4P		365	333	216	195	155
ZMQ2M 400/3P		465	413	308	286	190
ZMQ2M 400/4P		516	464	308	286	190
ZMQ2M 630/3P		525	474	318	295	195
ZMQ2M 630/4P		596	545	318	295	195

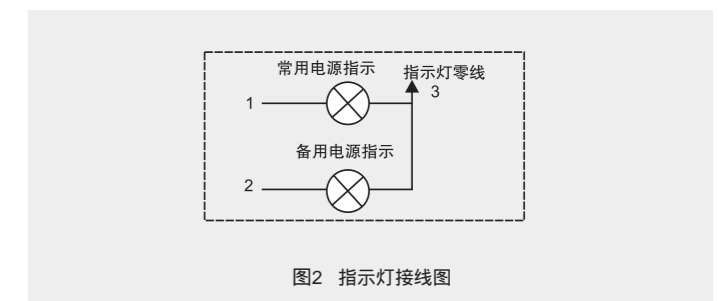

ZMQ2

系列双电源自动转换开关

Series twin power source auto transfer switch (ATS)



型号及含义 Type and meaning

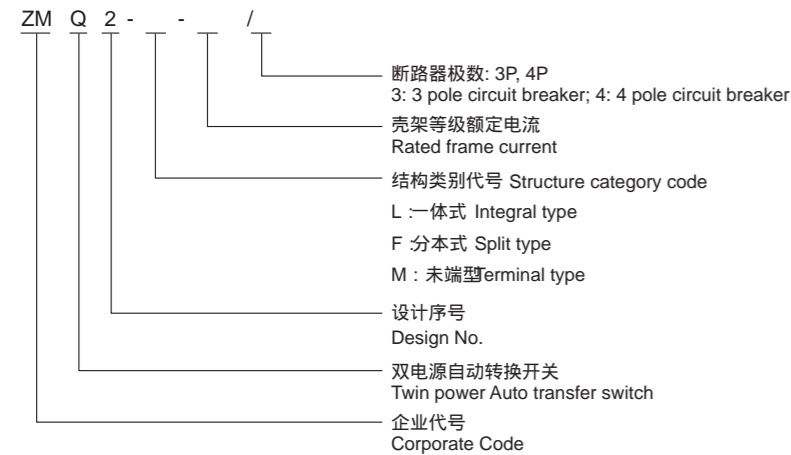

正常工作条件 Normal working condition

- 安装的海拔高度不超过2000米。
- 周围环境温度上限不高于+40℃，下限不低于-5℃，24小时平均值不超过+35℃。
- 大气的相对湿度在周围空气温度为+40℃时不超过50%，在较低的温度下，可以有较高的湿度，应考虑到湿度变化会发生产品表面的凝露。
- 无爆炸危险的介质，且介质不足以腐蚀和破坏绝缘的气体与尘埃。
- 无显著摇动和冲击震动的地方。
- The installation altitude not exceeding 2000 meters.
- The upper limit of the ambient temperature is not higher than +40°C, the lower limit of not less than -5°C, 24-hour average does not exceed +35°C.
- Atmospheric relative humidity in the ambient air temperature is +40℃ not more than 50%, at lower temperatures can have a higher humidity, condensation products should take into account the surface of the humidity change.
- No explosive medium, the medium does not enough to corrode and damage the insulation of gas and dust.
- No significant shake and shock vibration.

适用范围 Application

ZMQ2/F系列智能自保双电源转换开关(以下简称开关)适用于交流50Hz, 额定工作电压400V, 额定工作电流16A~2000A。使用于紧急供电系统的两路电源常用电源(N)与备用电源(R)之间的互相转换(也可设定为手动)和作为控制、信号、联锁等用途的控制电路的开关, 本品在某些型号中带有通讯专口, 可实现远程控制, 让用户实现无人值守变电所。适用于住宅小区、军事设施、医院、商场机场等场所。

ZMQ2 / F Series intelligent self-protection dual power switch (hereinafter referred to as switch) for AC 50Hz, rated working voltage 400V, rated current 16A ~ 2000A. Mutual conversion used in emergency power supply system of two common power supply (N) and standby power (R) between (can also be set to manual) and as a control, signaling, interlocking and other uses of the switching control circuit, the present products with some models designed communication port, which enables remote control, allowing users to achieve unattended substation. Suitable for residential areas, military facilities, hospitals, shopping malls, airports and other places.

结构与功能 Structure and Function

- 本智能转换开关由微电脑控制器和开关转换装置两大部分组成, 二者之间有专用线缆连接。
- 开关由微电脑控制器、微型电动机、齿轮机、微动开关、操作键盘、LGD显示屏、塑壳断路器等组成。具有自动、手动操作; 机械电器双重联锁等特点, 最大程度满足供、配电需要。
- 开关工作有三个状态位置供用户选择: 常用电源(N)合、双分、备用电源(R)合, 开关具有体积小、重量轻、工作稳定, 使用方便等特点。
- The intelligent switch two parts by the microcomputer controller and switching device component, a dedicated cable connection between the two.
- Switching from the microcomputer controller, micro-motors, gear machine, micro switch, keyboard, LGD display, molded case circuit breakers and other components. With automatic and manual operation; machinery and electrical double interlock features to best meet supply and distribution needs.
- There are three state switching positions for users to choose: the common power supply (N) together, double points, standby power (R) together, the switch has a small size, light weight, stable, easy to use features.

智能控制器功能

ZMQ2F/L是一款新型智能自保双电源转换开关。智能控制器由键盘位输入和(LCD)显示, 可对常用电源(N)和备用电源(R)三相同步检测: 对断相、失压或欠压, 低于额定工作电压值的85%时判为欠压, 备用电源(R)故障报警及双分, 微机对检测结果做出处理, 然后发出相应指令, 处理结果可显示在(LCD)上, 给用户一个良好的人机对话界面, 报警亦可人工关闭()。当前无论工作在何等模或下, 微机检测到异常数据, 3S从异常电源断开进入双分保护状态, 经延时(0-30S)转换到正常电源供电。例: 自投自复模式, 常用电源(N)出现异常将自动转换到备用电源(R)供电, 如常用电源(N)恢复正常则自动返回, 如两路工作电源同出现故障, 微机3S后将发出双分指令, 其电源恢复正常者优先工作。

工作模式: 自投自复式 适用电网与电网
自投不自复式 适用电网与电网
自投自复式 适用电网与电网
内置发点和消防功能(DC24V)

注: "自保"是ZMQ2F/L系列中的特色, 当电源出现异常具有先保护再延时的特点。

自投自复电网 ↔ 电网

开机初始默认自动、常用(手动、(任一相过压、欠压失压或断相)时, 双分)电源供电, 当电源出线异常控制器LCD上的NA、NB、NC、RA、RB、RC会相应消失。常用电源(N)出现异常3S后自动切换到双分状态, 经延时切换到备用电源(R)供电, 延时时间可设定为0-30S, 出厂时设定为3S。当常用电源恢复正常后, 则自动切换到常用电源(N)供电; 备用电源(R)出现异常控制器会发出“嘟嘟”的报警声。该报警亦可人为关闭()。LCD上“报警”字样消失, 表示报警系统已关闭。按下减键() “报警”字样显示, 同时会发出“嘟”一声, 表示报警系统已打开。

自投不自复电网 ↔ 电网

开机初始默认自动、常用(手动、双分)电源供电, 当电源出线异常(任一相过压、欠压、失压或断相)时, 控制器LCD上的NA、NB、NC、RA、RC。RC会相应消失。常用电源(N)出现异常3S后自动切换到双分状态, 再经延时切换到备用电源(R)供电, 延时时间可设定为0-30S, 出厂时设定为3S。当常用电源恢复正常后, 则不能自动返回常用电源(N)供电; 需手动返回; 备用电源(R)出现异常, 控制器会发出“嘟嘟”的报警声。该报警亦可人为关闭()。LCD上“报警”字样消失, 表示报警系统已关闭。按下减键() “报警”字样显示, 同时会发出“嘟”一声, 表示报警系统已打开。

自投自复电网 ↔ 发电时设定15S

控制器对常用电源(N)及发电电源(R)进行检测, 当常用电源(N)出现异常时, 系统给发电机组发出一条发电指令(常闭触点)和卸载指令(常开触点)启动发电机组, 当电网电压(N)恢复正常后, 控制系统经延时, 则自动返回到常用电源(N)供电, 发电机组需人工关闭。

Intelligent controller function

ZMQ2F / L is a new intelligent self-protection dual power switch. Intelligent controller bit input from the keyboard and display (LCD), can the common power supply (N) and standby power (R) is a three-phase synchronous detection: For phase loss, loss of pressure or voltage, lower than the rated working voltage of 85% when judged as undervoltage, standby power (R) fault alarm and double points for the computer test results to make a deal, and then issue the appropriate command, and the results can be displayed on (LCD), to give the user a good interactive interface The alarm can also be artificial close (). No matter what the current work in the mold or, often lead to computer testing data, 3S from abnormal power-off points into the double protection status, by the delay (0-30S) converted to a normal power supply. After the automatic recovery mode, the common power supply (N) exception will automatically switch to standby power (R) power supply, such as the common power supply (N) to resume normal automatically return, such as two-way work of a power failure, computer 3S same appears: Example double points will be issued instruction, the power returned to normal priority.

Operating modes: from the vote since Duplex 适用电网与电网
Since the vote of no self penthouse 适用电网与电网
From the vote since Duplex 适用电网与电网
Built-in point and fire function (DC24V)

NOTE: "Self" is ZMQ2F / L series feature when power supply is abnormal having first protected and then delay characteristics.

Automatic recovery grid ↔ Grid

The initial default auto power, commonly used (manual, (any one phase overvoltage, undervoltage, loss of voltage or phase), the double points) power supply, power outlet when the LCD controller abnormal NA, NB, NC, RA, RB, RC accordingly disappear. Common automatic switching power supply (N) to double after abnormal 3S sub-state, by the delay switch to standby power (R) power supply, the delay time can be set to 0-30S, factory setting is 3S. When the normal power supply back to normal, then automatically switch to the common power supply (N) power; standby power (R) abnormal controller will issue a "beep" sound the alarm. The alarm can also be artificially closed. LCD on the "Alarm" words disappear, indicating that the alarm system is turned off. Press the Save button "alarm" is displayed, and it will issue a "beep" sound, indicating that the alarm system is turned on.

Since the vote of no self-recovery grid ↔ Grid

The initial default auto power, commonly used (manual, double points) supply, when the power outlet abnormal (any one phase overvoltage, undervoltage, loss of pressure or off-phase), NA on the LCD controller, NB, NC, RA, RC. RC accordingly disappear. Common automatic switching power supply (N) abnormal 3S after sub-state to double again by the delay switch to standby power (R) power supply, the delay time can be set to 0-30S, factory setting is 3S. When the normal power supply returns to normal, you can not automatically return to the common power supply (N) power supply; manually return; standby power (R) is abnormal, the controller will issue a "beep" sound the alarm. The alarm can also be artificially closed. LCD on the "Alarm" words disappear, indicating that the alarm system is turned off. Press the Save button "alarm" is displayed, and it will issue a "beep" sound, indicating that the alarm system is turned on.

Automatic recovery grid ↔ Power Generation (delay setting 15S)

The controller of the common power supply (N) and power supply (R) to detect when the common power supply (N) appear abnormal, the system issues a turbine to generate electricity directive (normally closed contact) and uninstall instructions (normally open contact) start the generator set, when the grid voltage (N) to return to normal, the control system has been delayed, it automatically returns to the common power supply (N) power generators need to manually shut down.

ZMQ2

系列双电源自动转换开关

Series twin power source auto transfer switch (ATS)



主要技术参数 Main Technical data

规格 Type	断路器型号 Breaker Model	壳架电流(A) Frame current	额定工作电流(A) Rated operating current	开断电流(kA) Breaking current	额定工作电压(V) Rated working voltage	绝缘电压(V) Insulation voltage	频率 Frequency	延时时间 Delay time	控制器额定工作电压(V) Rated working voltage controller	机械寿命 Mechanical life	
ZMQ2F/L-100/3	CM1系列 TM30系列	100	10,16,20,32,40	参见具 体型号 断路器 说明书	400	2500	50~60Hz	0~30秒 可调	AC230V	5000次	
ZMQ2F/L-100/4			50,63,80,100								
ZMQ2F/L-225/3		225	100,125,140,160								
ZMQ2F/L-225/4			180,200,225								
ZMQ2F/L-400/3		400	200,250,315								350,400
ZMQ2F/L-400/4											400,500,630
ZMQ2F/L-630/3		630	250,315,350								400,500,630
ZMQ2F/L-630/4											630,700,800
ZMQ2F/L-800/3		800	630,700,800								
ZMQ2F/L-800/4											
ZMQ2F/L-1250/3	2000	1250,1600,2000									
ZMQ2F/L-2000/3											

LCD显示和控制器设置说明:

NA、NB、NC表示常用三相电源(UN)指示，RA、RB、RC表示备用三相电源(UR)指示，字母显示表示工作正常，闪烁或消失表示异常；“报警”字样显示表示报警系统已打开，“报警”字样消失表示报警系统已关闭。“双分”显示表示已进入双分工作模式，否则已退出双分模式。

SET设定键、⊕移位 ⊕增、⊖减，初始密码为8888。内部参数厂方已预设好，用户无需改动。“03S”延时时间“FFF1”自复、“FFFO”不自复，“SF08”双分时间，“N P”闪动为常用优先，“P N”为备用优先。

NA, NB, NC represent commonly used three-phase power supply (UN) instructions, RA, RB, RC represents an alternate three-phase power supply (UR) instructions, the letter display indicates normal operation, flashing or disappear showing abnormal; "Alarm" is displayed represents the alarm the system is turned on, the "alarm" word disappears indicates that the alarm system is turned off. "Two stars" display that has entered the sub-working dual-mode, dual points otherwise has quit mode.

SET Set, ⊕ displacement ⊕ increase, ⊖ decrease, the initial password is 8888. Good internal parameter factory preset, users do not need to change. "03S" delay time "FFF1" from the complex, "FFFO" no self-recovery, "SF08" double divided time, "N P" is flashing common priority, "P N" standby priority.

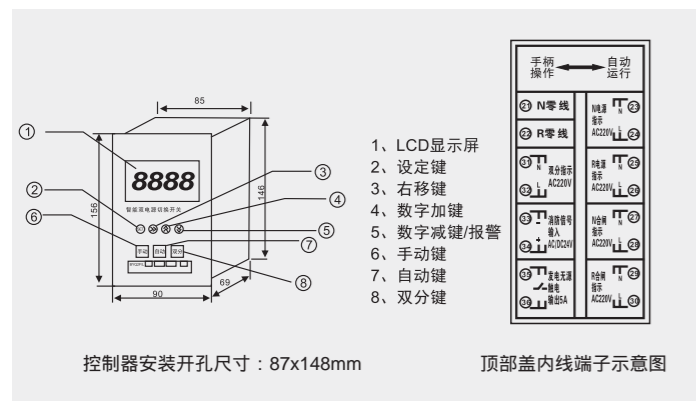

注：LCD显示自投自复简称(自复)，自投不自复简称(不自复)，"SF01"不可改动。

底部接线端子"1"至"10"分别为："1"空脚，"2"至"5"为常用电源A, B, C, N输入端，"6"至"9"为备用电源A, B, C, N输入端，"10"空脚"11"至"13"为电机控制线，"14"至"18"为空脚。

顶部盖内线端子"21"至"36"表示如下："21"为常用电源零线(UN-N)，"22"为备用电源零线(UR-N)，注：21,22在开关采用三极时，零线输入使用，当开关选用四极时21、22不要接入零线。"23" "24"为常用电源指示输出到信号灯(220V)，"25" "26"为备用电源指示输出到信号灯(220V)。"27" "28"为常用开关闭合信号输出至信号灯(220V)，"29" "30"为备用开关闭合信号输出至信号灯，"31" "32"为开关双分状态信号输出至信号灯(220V)，"33" "34"消防信号输入AC/DC12V-24V，"35" "36"为发电机启动信号无源触点。

"检修 运行"为拨动开关：按钮在检修侧，控制器不能正常运行双电源操作机构不能由控制器控制，只能用手柄来操作。

Bottom terminals "1" to "10" are as follows: "1" empty legs "2" to "5" for the common power supply A, B, C, N input, "6" to "9" for the standby power A, B, C, N input, "10" empty leg "11" to "13" for motor control line "14" to "18" is empty foot.

Top cover inside the terminal "21" to "36" as follows: "21" for the common neutral wire (UN-N), "22" for the standby power zero line (UR-N), Note: 21 and 22 using the switch when the three-pole, the zero line inputs, when the switch selection quadrupole 21 and 22 do not access the zero line. "23" "24" indicates a common power output to the signal (220V), "25" "26" is output to a signal indicating the standby power (220V). "27" "28" closing signal to the signal (220V) for the common switch, "29", "30" closed signal output to the signal as an alternate switch, "31", "32" for the switch double points status signal to the signal (220V), "33" "34" fire signal input AC / DC12V-24V, "35" "36" for the generator start signal passive contact.

"Inspection run" for the pull switch: Button in the repair side of the controller can not run normally dual power operation mechanism can not be controlled by the controller can only be used to operate the handle.

外形及安装尺寸 ATS Dimensions

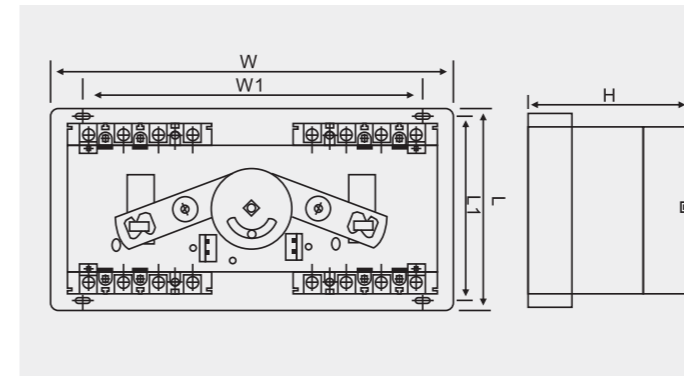

分体、一体式 Split, integrated

规格 Type	尺寸 Dimension	W	W1	L	L1	H
ZMQ2F/L-100/3P		390	350	210	190	120
ZMQ2F/L-100/4P		495	460	210	190	135
ZMQ2F/L-225/3P		430	395	215	195	140
ZMQ2F/L-225/4P		545	510	215	195	140
ZMQ2F/L-400/3P		565	510	310	285	190
ZMQ2F/L-400/4P		635	585	320	285	190
ZMQ2F/L-630/3P		630	575	320	295	195
ZMQ2F/L-630/4P		715	665	320	295	195
ZMQ2F/L-800/3P		710	655	335	315	190
ZMQ2F/L-800/4P		785	725	335	315	190
ZMQ2F/L-1250/3P		735	680	480	365	280
ZMQ2F/L-2000/4P		800	750	480	365	280

安装及使用方法 Installation and Use

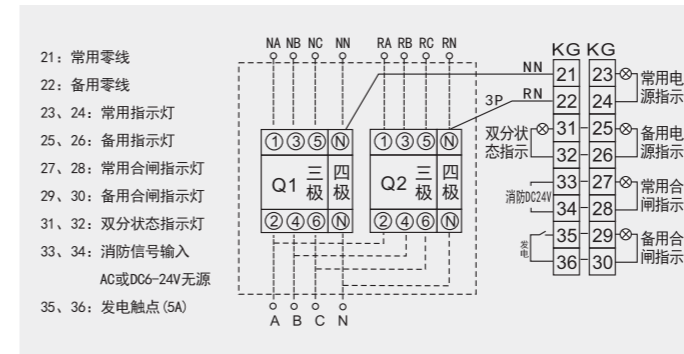

注：上图仅供用户参考，综合功能接线图根据型号功能不同，接线图也有所不同。当发生火灾时，EPS消防信号启动（消防中心提供），使01、02断路器脱扣或处于断开状态。

(NH、RH)电源指示灯AC220V（用户自备）外置；

(KG)接线端子

(Q1、Q2)断路器；

(内置)发电、卸载触点

虚线部分由用户自备。

例：接线端子(KG)

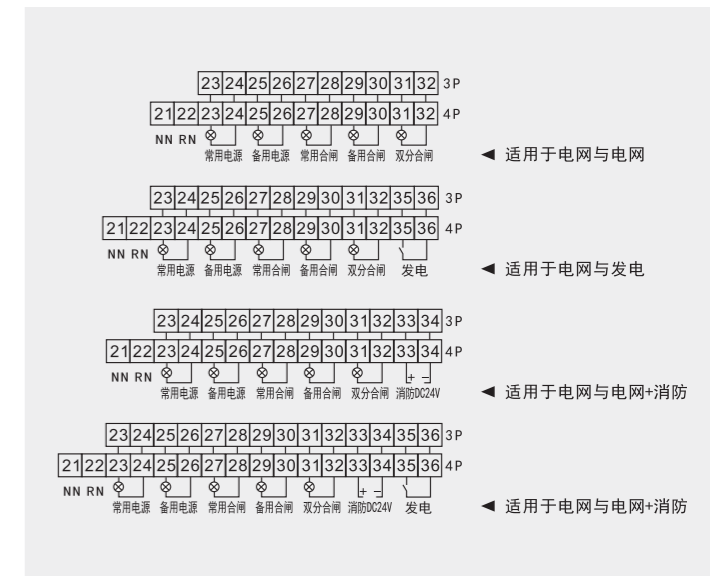

注：三极断路器(3P), 四极断路器(4P), DC24V (外置)消防中心提供

使用维护 Maintenance

- 开关具有手动、自动、双分操作指令键，自动控制状态时紧急断开操作，自动控制操作有以下几种操作功能。
- 手动操作：第一次按下手动键进入手动、常用工作状态，再按下此键则进入手动、备用工作状态。此时工作状态下电源出线异常，3S则自动进入保护状态将切换到双分位。
- 自动操作：根据用户场合需要功能其分自复模式和自投不自复模式两类：
- 自投自复模式：开机初始默认常用供电，当常用电源出线异常经延时切换备用电源供电，如常用电源恢复正常后则自动从备用返回常用电源供电。
- 自投不自复模式：基本功能同上，不同的是常用电源恢复正常后则不能自动返回，需手动返回。
- 双分模式：用户在特殊情况下，按下双分键，系统将会同时断开常用电源和备用电源，断开负载供电。
- Switch with manual, automatic, dual operation instruction key points, the emergency disconnect when the automatic control operation, automatic control operations are the following operating functions.
- Manual operation: first press manually enter manually, often working state, press the button again to manually enter the standby state. In this case the power outlet abnormal working condition, 3S will automatically enter the protected status will switch to double-digit points.
- Automatic operation: two types of its division multiplexing mode and from the vote since no self-recovery mode functions according to user needs occasion:
- Automatic recovery mode: Power supply common initial default, when the common power outlet abnormal by the delay switching backup power supply, such as a common power supply returns to normal after the automatic return from the common power supply backup.
- Since the vote of no self-recovery mode: Basic functions above, except that the common power supply returns to normal after the return is not automatic, manually return.
- Dual distribution patterns: Users in exceptional circumstances, double points press button, the system will be disconnected while the common power supply and backup power, disconnect the power to the load.

ZMQ5

系列双电源自动转换开关

Series twin power source auto transfer switch (ATS)

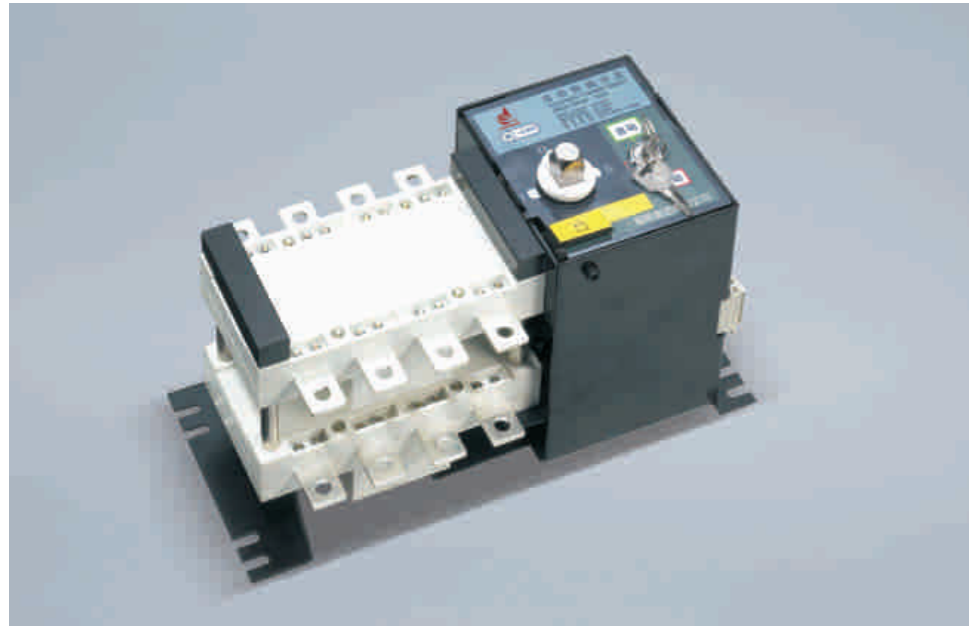

型号及含义 Type and meaning

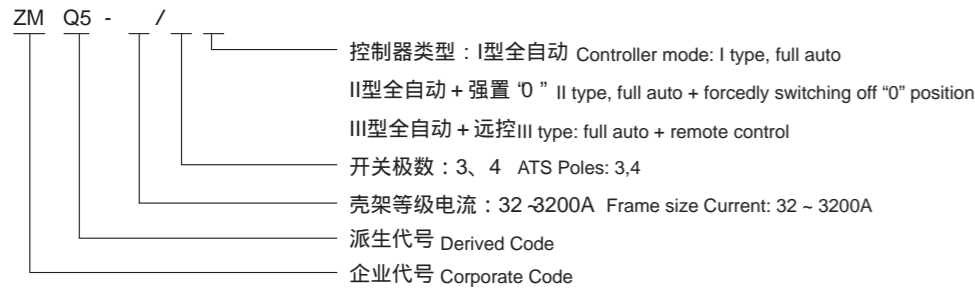

开关结构说明 Instruction of switch structure

1. 电气钥匙：控制开关内部控制线路电源，电气锁开启时，开关可实现全自动、远控、强置“0”操作；电气锁关闭时，开关只能手动操作。
2. 操作手柄：使用操作手柄手动操作时，必须先关闭电气锁。
3. 机构挂锁：检修专用，即先用操作手柄使开关处于“0”档位置，再拉起挂锁机构并上挂锁，方可进行检修（拉起挂锁则切断开关内部控制电源，开关无法自动，并且无法实现手动）。
4. 指示件：指示开关的工作状态位置（I、O、II）。

1. Electric key: to control the power source for inner control circuit in the switch, when electric lock is opened, full auto operation, remote control, forcedly switching off operations can be executed; while electric lock is closed, the ATSE can be operated by hand.
2. Operating handle: before to use operating handle to operate, please close electric lock.
3. Padlock: special for inspection and repair, namely make the switch in 0 position by use of operating handle, then hung the padlock for safety against power source wrong closed, finally inspection and repair can be executed (when padlock is locked, it cut off power source for inner circuit, ATSE can't be closed automatically or by hand).
4. Indication parts: to indicate the working positions: (I、O、II)

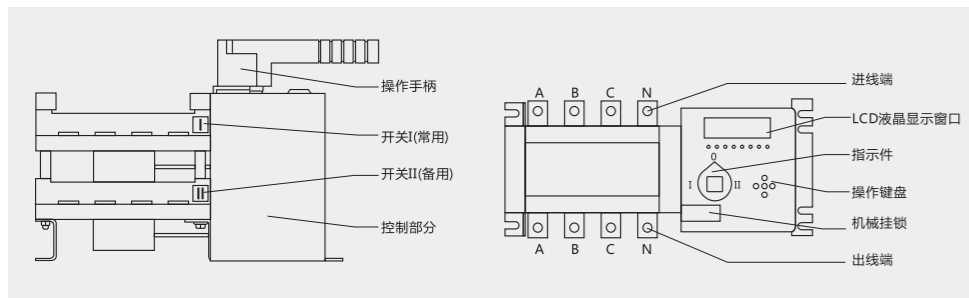

适用范围 Application

自动转换开关 (ATSE) 是集开关与逻辑控制于一体、真正实现机电一体化的自动转换开关，它适用于交流 50Hz、额定电压 AC400V、约定发热电流至 1600A 的工业企业配电网中，具有电压检测、强制置“0”、紧急手动操作，广泛应用于供电系统的主电源与备用电源的自动转换或两台负载设备的自动转换及安全隔离等。开关由控制线路板发出各种逻辑命令来管理电机，由电机带动开关主体部分的操作机构，快速接通分断电路或进行电路转换，通过明显可见状态实现安全隔离。

Auto transfer switching equipment (ATSE, ATS), is a device integrated with the switching function and logic control, truly perform electromechanical integration function, suitable for operating in the distribution system of AC50Hz, rated voltage AC400V, conventional thermal current up to 1600A in mineral and other enterprises. It provides the operation function of voltage detection, forcedly switching off “0” position, manual emergency operation and etc, widely used to shift between normal power and standby power or two loading equipment, or perform safe isolation and etc. the control circuit board will govern the motor through logic commands, then motor will drive the operating mechanism of main switches, quickly closing or opening or shift the lines, the safe isolation of main switch is obvious and legible by eye.

主要技术参数 Main Technical data

- 开关符合 IEC6094-6-1, GB14048.11-2008
- 额定工作电压 (Ue) : AC400V ;
- 额定绝缘电压 (Ue) : AC690V ;
- 额定工作电流 (Ie) : 10-3200A ;
- 控制电源电压 : DC24V, DC48V, AC230V
- Complied standard: IEC6094-6-1, GB14048.11-2008
- Rated operating voltage (Ue): AC400V;
- Rated insulation voltage (Ue): AC690V;
- Rated operating current (Ie): 10 ~ 3200A;
- Control supply voltage: DC24V, DC48V, AC230V

主要技术参数 Main Technical data

约定发热电流 (A) Conventional thermal current	100	160	250	400	630	1000	1250	1600	2000	2500	3200	
额定绝缘电压 Rated insulation voltage	750V			1000V			1000V					
额定冲击耐受电流 Rated impulse withstand current	8kV			12kV			12kV					
额定工作电流 (A) Rated operating current	AC-31A	100	160	250	400	630	1000	1250	1600	2000	2500	3200
	AC-35A	100	160	250	400	630	1000	1250	1600	2000	2500	3200
	AC-33A	100	160	250	400	630	1000	1250	1600	2000	2500	3200
额定短时耐受电流 Rated short time withstand current	7kV	9kV		13kV		50kV		55kV				
额定限制短路电流 Rated short-circuit current limit	100kA			70kA		100kA		120kA		80kA		
控制电源电压 Control supply voltage	DC24V, 48V, 110V, AC220V											
转换时间 (s) Conversion time	0.5	1	1.1	1.2		1.25		2.45				

接线示意图 Wiring diagram

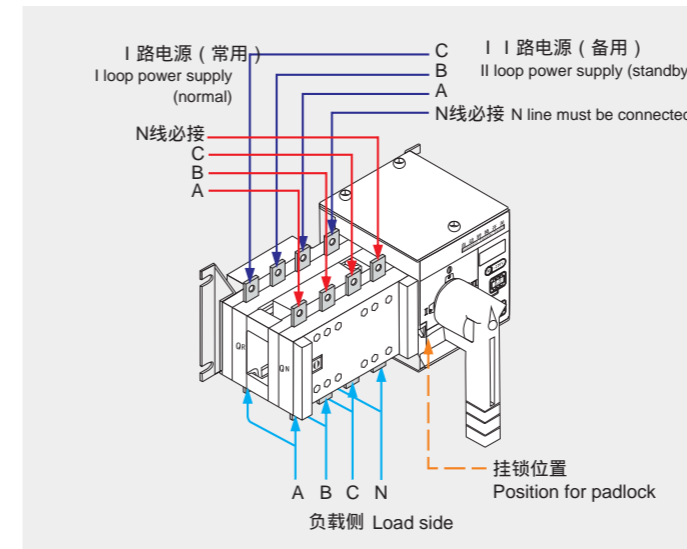

端子接线操作说明 Operation instruction for terminal wiring

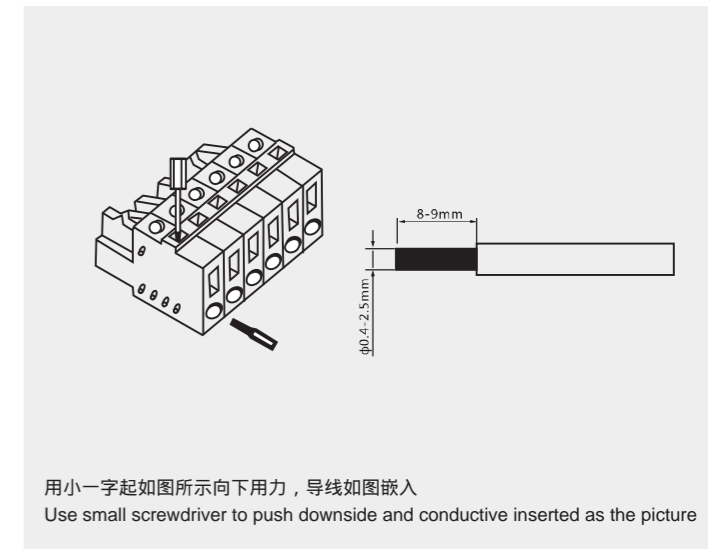

使用方法 Usage method

- 开关功能
 1. 全自动功能：当常用电源断电时，开关自动转换至备用电源；当常用电源恢复正常时，开关又自动返回转换至常用电源。
 2. 强置“0”功能：启动强置“0”按钮，开关将切断两路电源。
 3. 远程控制功能：即远距离控制，按下“I”档按钮；则常用电源工作；按下“II”档按钮，则备用电源工作；按下“0”档按钮，则切断两路电源。
- 4. 请根据需要选择开关功能，并按相应功能接线。
- 5. 订货时请指明开关型号、电流规格及所需功能。
 - 1 Full auto function: when normal power is off, the ATSE auto transferred to standby power; when normal power recover, ATSE will auto transferred to normal power again.
 - 2 The function of forcedly switching off “0” position: push “0” button forcedly, ATSE will cut off two loops of power supply.
 - 3 Remote control function: push “I” button, normal power will be in service; push “II” button, then standby power will put into use, push “0” button, to cut off two loops of power supply
 - 4 Please select the switching function according to requirement and connect the wire correctly.
 - 5 When to book product, please indicate the ATSE model, current rating and the function you need.

开关正确安装方法 Correct mounting method

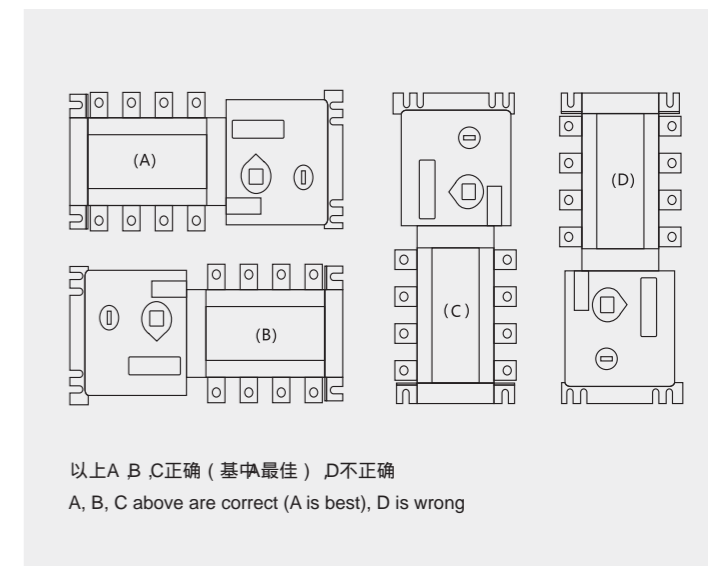

ZMQ5

系列双电源自动转换开关

Series twin power source auto transfer switch (ATS)



外形及安装尺寸 Dimensions

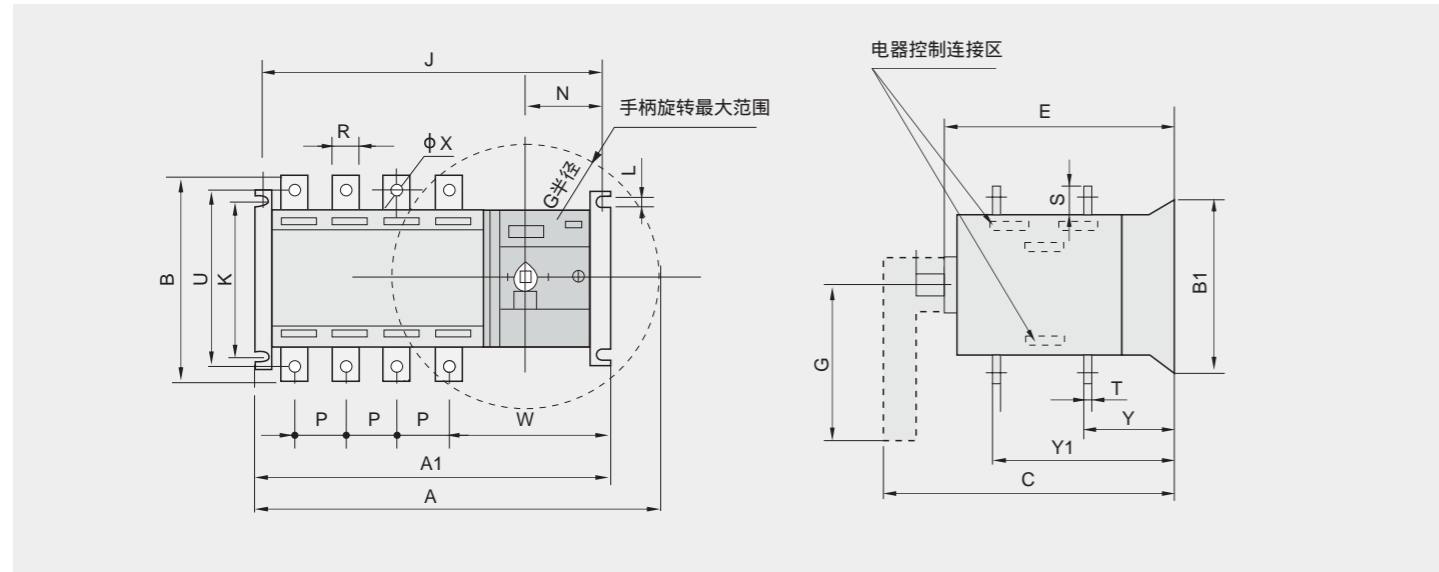

规格In Type	外形尺寸与安装尺寸 Dimensions																			
	A	A1	B	B1	C	E	G	J	K	L	N	P	R	S	T	U	W	X	Y	Y1
100A/3	235	232	106	105	134	133	115	221.5	84	7	74.5	30	14	18	2.5	105	126	6	36	86
100A/4	247	244	106	105	134	133	115	233.5	84	7	74.5	30	14	18	2.5	105	126	6	36	86
125A/3	292	270	135	128	230	189	145	254	102	7	91	36	20	25	3.5	127	158	9	55	125
125A/4	322	300	135	128	230	189	145	284	102	7	91	36	20	25	3.5	127	158	9	55	125
160A/3	292	270	135	128	230	189	145	254	102	7	91	36	20	25	3.5	127	158	9	55	125
160A/4	322	300	135	128	230	189	145	284	102	7	91	36	20	25	3.5	127	158	9	55	125
250A/3	356	312	170	142	261	208	145	293	102	7	91	50	25	30	3.5	142	158	11	60	145
250A/4	406	362	170	142	261	208	145	343	102	7	91	50	25	30	3.5	142	168	11	60	145
400A/3	487	368	260	222	284	273	189	351	180	9	93	65	32	40	5	222	168	11	83	193
400A/4	552	433	260	222	284	273	189	416	180	9	93	65	32	40	5	222	203	11	83	193
630A/3	487	368	260	222	284	273	189	351	180	9	93	65	40	50	6	222	203	12	83	193
630A/4	552	433	260	222	284	273	189	416	180	9	93	65	40	50	6	222	203	12	83	193
800A/3	646	519	357	250	363	350	443	499	220	11	87	120	60	69	8	250	203	12.5	109	254
800A/4	760	633	357	250	363	350	443	613	220	11	87	120	60	69	8	250	207	12.5	109	254
1000A/3	646	519	357	250	363	350	443	499	220	11	87	120	60	69	8	250	207	12.5	109	254
1000A/4	760	633	357	250	363	350	443	613	220	11	87	120	60	69	8	250	207	12.5	109	254
1250A/3	646	519	357	250	363	350	443	499	220	11	87	120	80	69	8	250	207	13	110	255
1250A/4	760	633	357	250	363	350	443	613	220	11	87	120	80	69	8	250	207	13	110	255
1600A/3	676	519	357	250	363	350	443	499	220	11	87	120	80	69	10	250	207	13	110	255
1600A/4	760	633	357	250	363	350	443	613	220	11	87	120	80	69	10	250	207	13	110	255
2000A	800	633	460		542		447	610			84.5		80	120	10					169
2500A	800	633	460		542		447	610			84.5		80	125	15					174
3200A	800	633	460		542		447	610			84.5		80	130	20					179

接插端子图 Terminal diagram

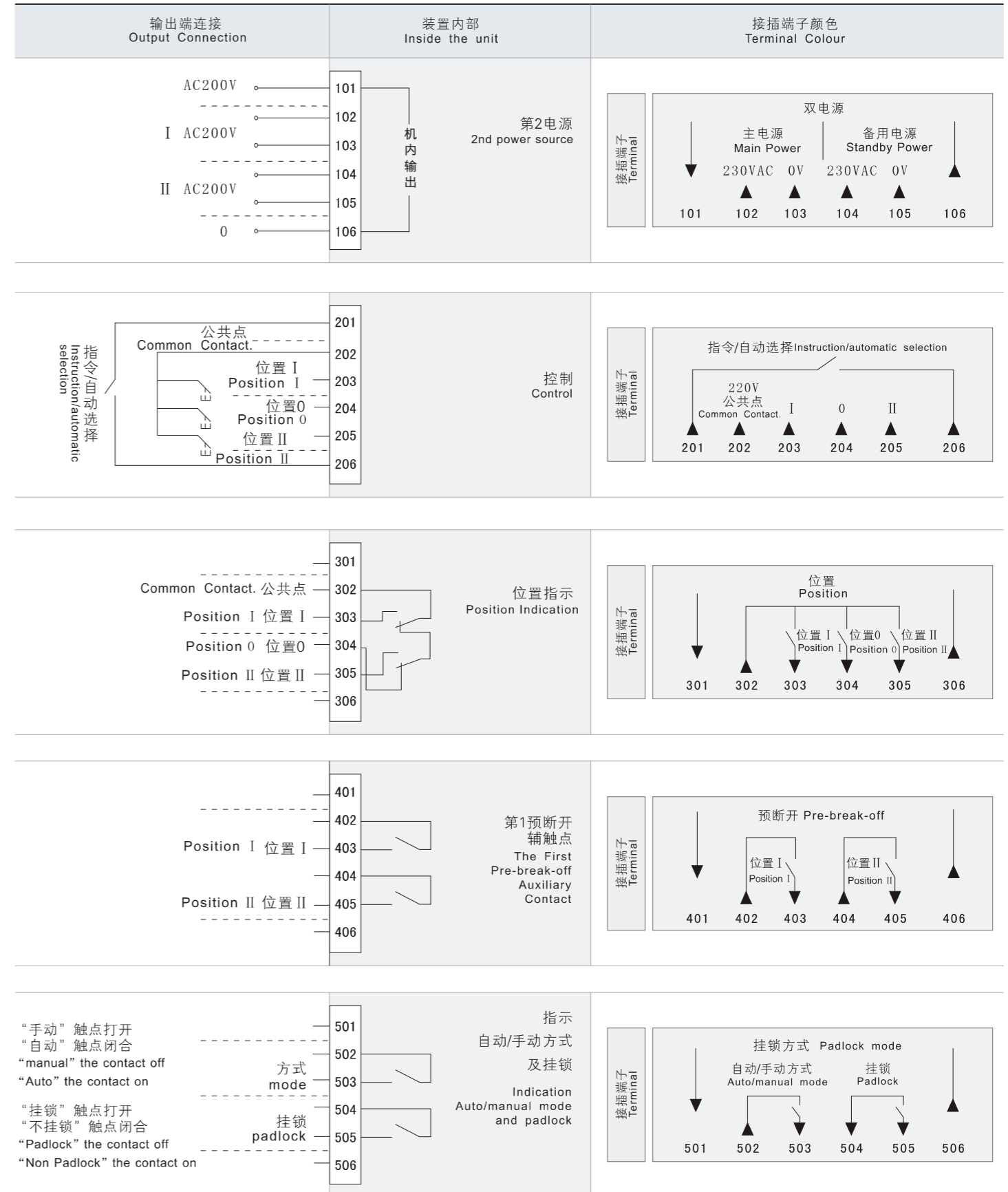

ZMQ5

系列双电源自动转换开关

Series twin power source auto transfer switch (ATS)

外接端子接线方式图 Wiring diagram of outer terminals

100典型接线方式 100 typical wiring mode

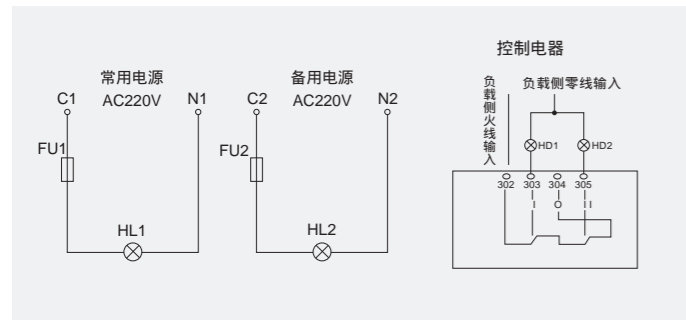

160-3200全自动接线方式 Wiring diagram of 160-3200 full auto mode

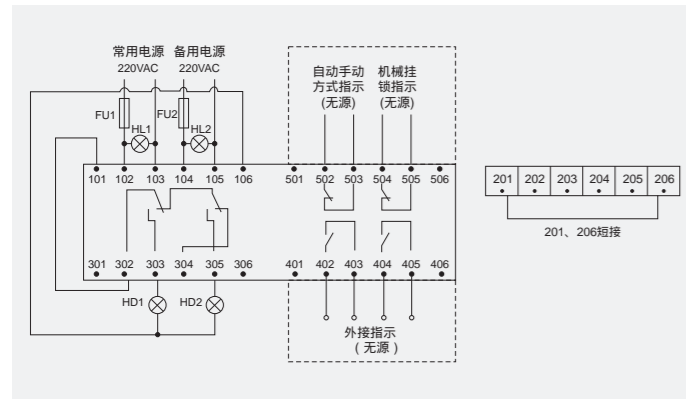

100-3200全自动+强制置“0”（双路电源均断开）接线方式 Wiring diagram of 100-3200 full auto mode + forcedly switching off "0"

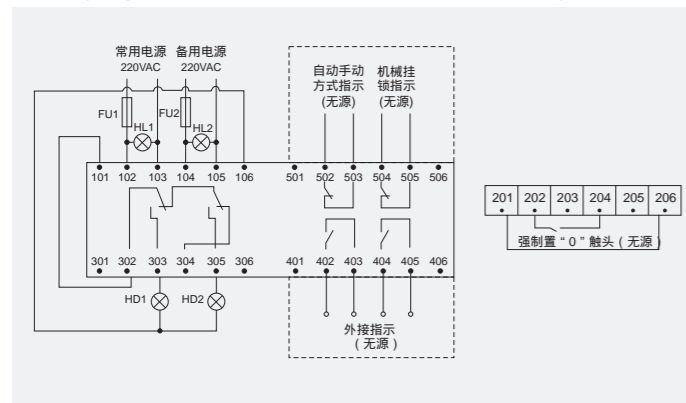

100-3200全自动+发电机信号输出接线方式

Wiring diagram of 100-3200 full auto mode +output signal of starting generator

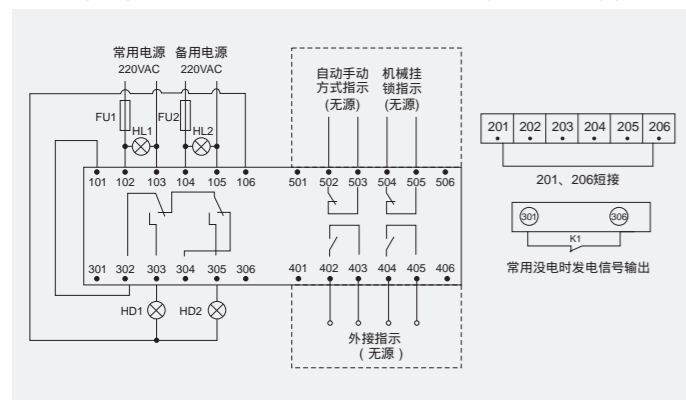

100-3200全自动+发电机信号输出接线方式 Wiring diagram of 100-3200 full auto mode +output signal of starting generator

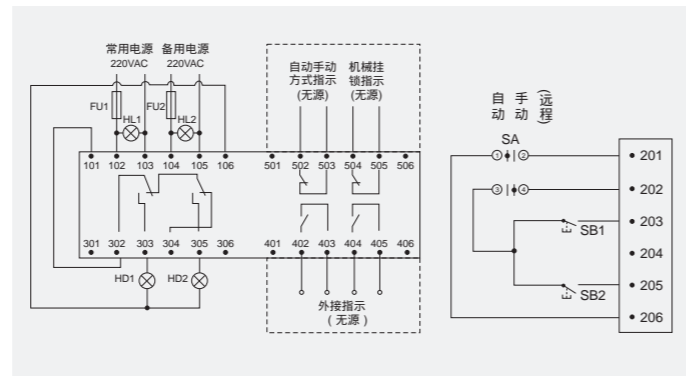

字母与符号说明

- 1、C1、N1分别为常用电源火线和零序，C2、N2分别为备用电源火线和零线。HL1、HL2分别为常用电源、备用电源有指示。HD1、HD2分别为常用电源、备用电源投入指示。FU1、FU2为2A保险丝。
- 2、101 -106、201 -206为自动转换开关二次接线端子
- 3、301 -306为自动转换开关外接指示灯端子
- 4、401 -406、501 -506自动转换开关端子可选用
- 5、全自动接线方式201、206必须短接
- 6、强制置“0”触头（无源）也可输DC24V电源
- 7、K1为发电信号输出（当常用没电时）
- 8、SA为自动 / 手动功能选择开关，SB1、SB2分别为常用电源，备用电源手动投入按钮（无源触头）

DC24V 接线方式 Wiring mode of DC24V

1、基本接线方式 Basic wiring mode

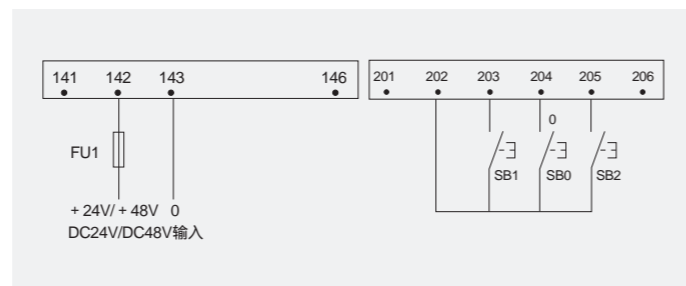

2、其它端子接线 Other terminal wiring.

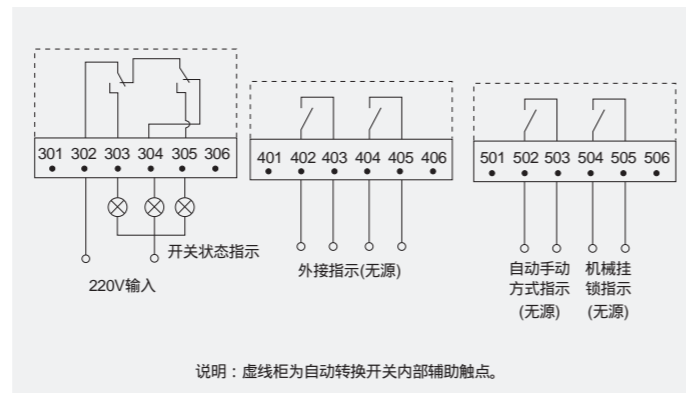

说明：虚线框为自动转换开关内部辅助触点。

DW15

系列万能式断路器

Series conventional circuit breaker

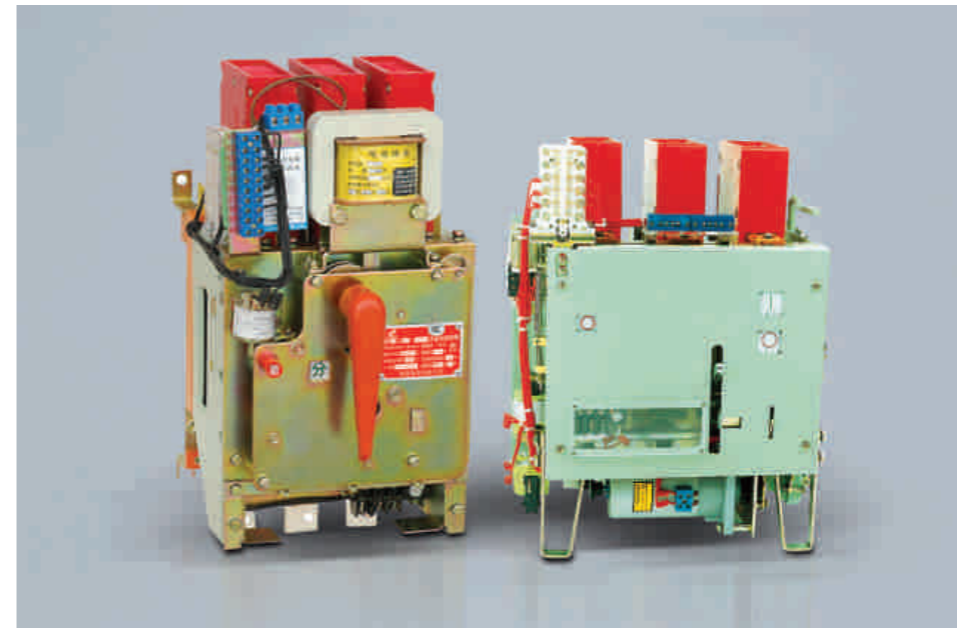

型号及含义 Type and meaning

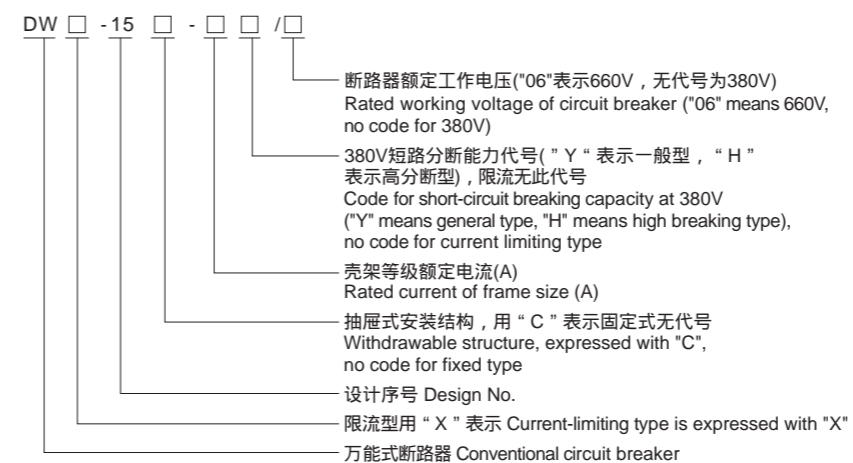

正常工作条件和安装条件 Normal working condition and mounting conditions

- 周围空气温度为：-5 ~ +40，24小时内其平均值不超过+35；
- 海拔高度：不超过2000m；
- 大气条件：在+40℃时空气相对湿度不超过50%；在较低温度下可以有较高的相对湿度，最湿月的月平均最低温度不超过+25℃，该月的月平均最大相对湿度不超过90%，并考虑因温度变化发生在产品上的凝露；
- 污染等级：3级；
- 安装类别：3级；
- 安装条件：安装面与垂直面倾斜度不大于±5°。
- 冲击振动：产品应安装和使用在无显著摇动、冲击和振动的地方。
- Ambient temperature: -5 ~ 40, daily average over 35
- Altitude not more than 2000m;
- Ambient conditions: relative humidity not more than 50% at 40, if lower temperature humidity can be higher, on the month when maxi average humidity occurs the Temperature shall be not more than 25, on this month the maxi average humidity shall not more than 90%, and there has considered the mist covering the product
- Polluted class: 3 grade
- Installation class: 3 grade
- Mounting conditions: the mounting inclined angle shall not more than +5°
- Impact vibration: there shall have no severe vibration, impact and vibration.

适用范围 Application

DW15系列万能式断路器(以下简称断路器)及DWX15系列万能式限流断路器(以下简称断路器)的额定电流100A至4000A(限流断路器至630A)，额定电压交流50Hz、380V至660V(Inm 1600A仅380V等级)。该断路器主要在配电网中用来分配电能，保护线路及电源设备的过载、欠电压和短路。DW15-630也能在交流50Hz、380V电网中用来保护电动机的过载、欠电压和短路，上述断路器除固定式结构外，还具有抽屉式结构。DW15-630及限流断路器在正常条件下可作为电动机的不频繁起动之用。限流断路器由于具有限流特性，特别适用于可能出现大短路电流的网络。

产品符合IEC60947-2、GB14048.2及JB8590.1标准。

DW15 series conventional circuit breaker (hereinafter referred to as circuit breaker) and DWX15 series conventional current-limiting circuit breaker (hereinafter referred to as circuit breaker), rated current 100A-4000A (current-limiting circuit breaker up to 630A), AC50Hz and rated voltage 380V-660V (Inm 1600A only class of 380V). They are mainly used to distribute electric energy, protect the circuit and power equipment against overload, under-voltage or short-circuit in the distribution network. DW15-630 also can be used to protect the motor against overload, under-voltage or short-circuit in power grid of AC 50Hz with voltage 380V, in addition to the fixed type structure, the circuit breaker also has with draw able type. Under normal conditions, this circuit breaker can be used to change over the circuits infrequently, DW15-630 and current-limiting circuit breaker also can be used for infrequent starting of motor. The current-limiting circuit breaker is especially suitable for networks that may come across heavy short-circuit current.

The products are in accordance with the standards IEC60947-2, GB14048.2 and JB8590.1.

DW15

系列万能式断路器

Series conventional circuit breaker



特点 Characteristics

DW15-200、400、630断路器为立体布置形式，触头系统、瞬时过电流脱扣器左右侧板均安装在一块绝缘板上。上部装有灭弧系统，操作机构可装在正前方或右侧面，有“分”、“合”指示及手动断开按钮。其左上方装有分励脱扣器，背部装有与脱扣半轴相连的欠电压脱扣器。速饱和电流互感器或电流电压变换器套在下母线上。欠电压延时装置、热继电器或半导体脱扣器可分别装在下方。

DW15-1000、1600、2500、4000断路器为立体面置形式，由底座、侧板、横梁组成框架，每相触头系统安装在底座上，上面装灭弧室。操作机构在断路器右前方，通过主轴与触头系统相连。电动操作机构通过方轴与机构连成一体装于断路器下部，作为断路器的贮能或直接闭合之用，贮能后的闭合由释能电磁铁承担。在左侧板上装有防回跳机构，以防止断路器在断开时弹跳。各种过电流脱扣器按不同要求装在断路器下方，欠电压、分励脱扣器及电动操作控制部分装在左侧，其中欠电压、分励脱扣器通过脱扣器与放大机构相连，以减少断路器的脱扣力。辅助触头供用户联接二次回路用，面板上有显示断路器工作位置的指示牌“ ” “ ”和“贮能”指示，还有供合闸及分闸用的按钮“ ” “ ”（均按下）。DW15-1000、1600断路器附有正面手动操作手柄；DW15-2500、4000附有检修用的手动操作手柄(均可卸下)。

DW15-200, 400 and 630 circuit breakers are arranged in tridimensional, the contact system and both left and right side plates of instantaneous over-current release are installed on the same insulation board. There is arc-extinguishing system in the upper part, the operating mechanism can be installed right ahead or right side, there are "ON" and "OFF" indications and manual breaking button. There is shunt release on the upper left side, and there is an under-voltage release that is connected with tripping half-shaft on the back. The rapidly saturable current transformer or current-to-voltage converter is put on the lower bus. Under-voltage delay device, thermal relay or semiconductor release can be installed in lower part respectively.

DW15-1000, 1600, 2500 and 4000 circuit breakers are arranged in tridimensional, they are composed of base frame, side plate and beam, these form into the framework, contact system of each phase is set on the base frame, with arc-extinguishing chamber installed at the top. The operating mechanism is set in right front, being connected with the contact system through the main shaft. The electric operating mechanism is integrated with mechanism through square shaft and is mounted in the lower part of circuit breaker, used for energy storing or direct closing of circuit breaker, the closing after energy storing will be at the responsibility of energy-releasing electromagnet. There is de-bounce device in the upper of left side plate, used for preventing circuit breaker from bouncing during opening. Various over-current releases are mounted in the lower part of circuit breaker according to different requirements, under-voltage and shunt releases as well as control part of electric operating mechanism are arranged on the left side, there into, the under-voltage and shunt releases are connected with the mechanism of amplification through the release, for reducing tripping force of circuit breaker. The auxiliary contacts are used for connecting with the secondary circuit, the panel has indicators of " ", " " and "ENERGY STORAGE" for showing the working position of circuit breaker, also has buttons " " and " " for closing and opening. DW15-1000 and 1600 circuit breakers have front manual operated handles; DW15-2500 and 4000 are attached with manual operated handles for overhaul purpose (both of them can be dismantled).

主要技术参数 Main Technical data

断路器壳架等级额定电流Inm(A) Rated frame current	630			1600	2500	6300
极数 Pole	3	3	3	3	3	3
额定电流 Rated current In(A)	100,160,200,315,400,630			630,800,1000,1600	1600,2000,4000,2500	2500,3000,4000,6300
额定极限短路分断能力 Icu(kA) Rated Ultimate short-circuit breaking capability Icu(kA)	20(50)	20(50)	20(50)	40	60	80
额定运行短路分断能力 Ics(kA) Rated Service short-circuit breaking capability	12	12	12	16	25	25
额定运行短路分断能力 Ics(kA) Rated Service short-circuit breaking capability	20(20)	20(20)	20(20)	30	40	50
进线方式 Incoming methods	上进线	上进线	上进线	上进线或下进线	上进线或下进线	上进线或下进线
机械寿命(次) Mechanical life	9000	9000	9000	4500	4500	3500
电寿命(次) Electrical life	1000	1000	1000	500	500	500
操作频率 Operating frequency(次/h)	15	15	15	40	40	40
操作频率 Operating frequency(次/h)	16	16	16	20	20	10
飞弧距离 Flashover distance(mm)	280(350)	280(350)	280(350)	350(450)	350(450)	400(500)
操作力臂 Operating arm of force(mm)	90	90	90	250	250	250
操作力 Operation of power(N)	200	200	200	300	300	300

注：a. DW15C-200、400、630技术参数同DW15-200、400、630。

b. DW15C抽屉座插接寿命为200次，DW15-6300(In 5000A)机械寿命免维护1500次。

c. 飞弧距离括号内为1140V产品。

d. 分断能力括号内的指标仅适用于限流型。

e. In=5000、6300A只有电磁式，其余均有热-电磁式和电磁式两种。

Note: a. Technical parameters of DW15C-200, 400 and 630 are the same as that of DW15-200, 400 and 630.

b. Service life of drawer seat of DW15C is 200 times, mechanical life of DW15-6300(In 5000A) free of maintenance is 1500 times.

c. Indexes of flashover distance in brackets are for products of 1140V.

d. Indexes of breaking capacity in brackets are for current-limiting types.

e. In=5000 and 6300A only have electromagnetic type, the rests have thermal-electromagnetic and electromagnetic two types.

外形及安装尺寸

mm单位：



图1. DW15-630外形尺寸图 (正面操作)

图2. DW15-630外形尺寸图 (侧面操作)

图3. DW15-630安装尺寸图

mm单位：

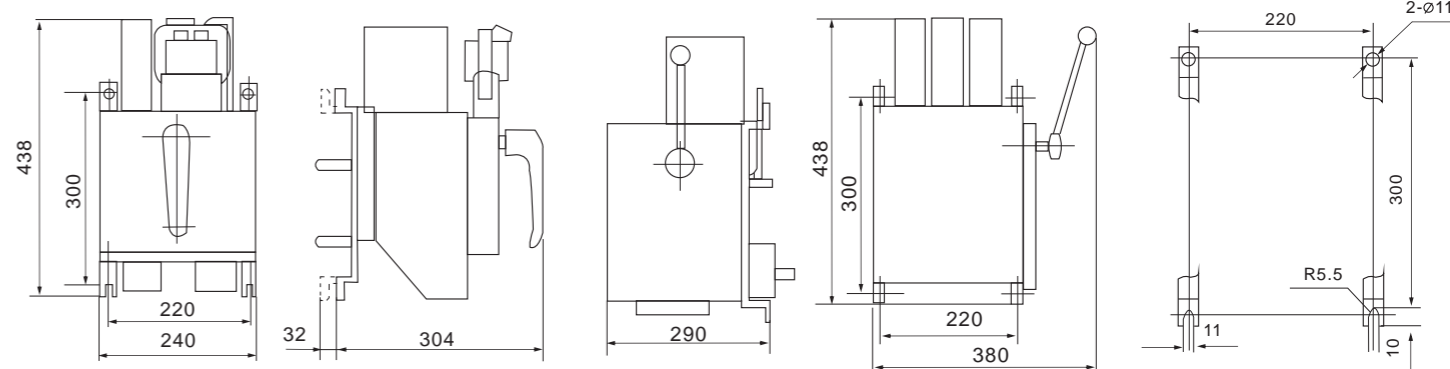

图4. DW15-1600外形尺寸及安装尺寸图

图5. DW15C-630安装尺寸图

mm单位：

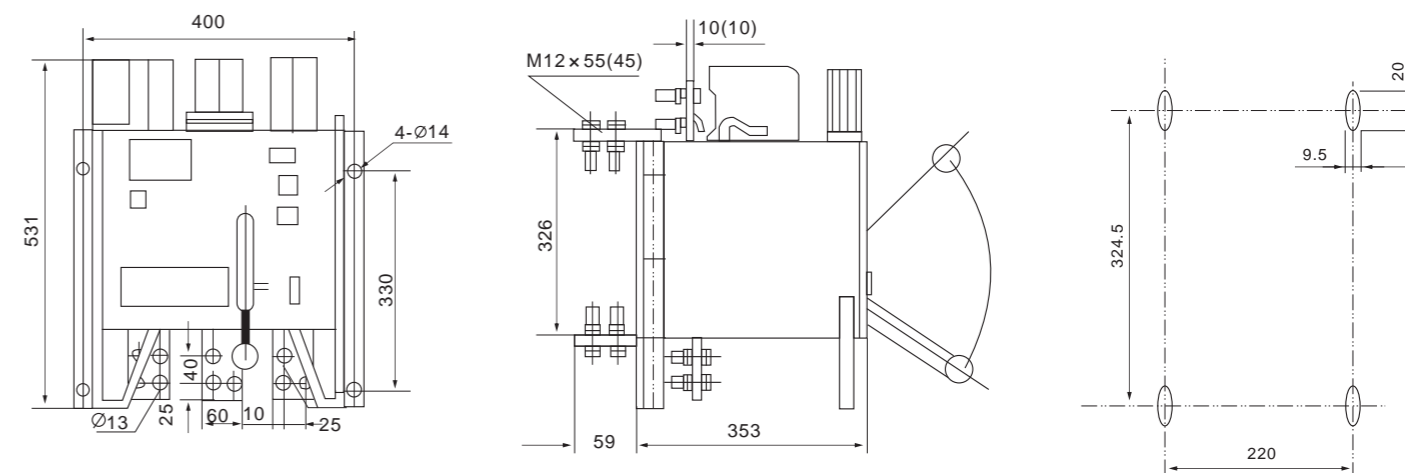

图6. DW15-4000外形尺寸及安装尺寸图

DW17

系列万能式断路器

Series conventional circuit breaker

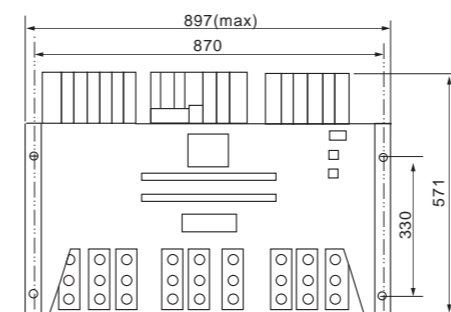
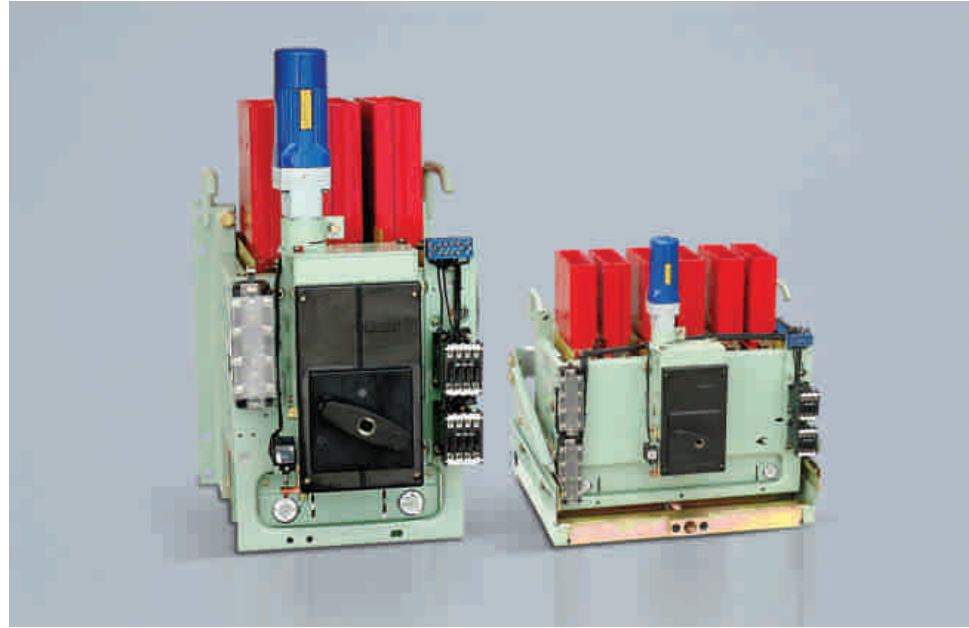

型号及含义 Type and meaning

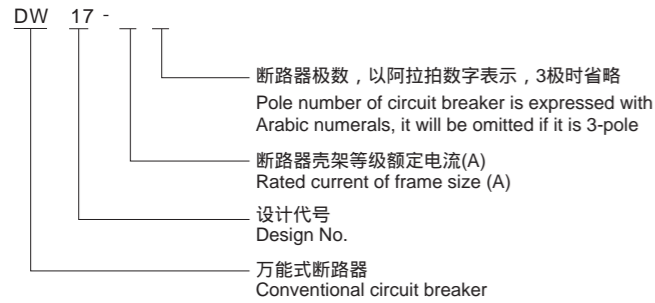

正常工作条件和安装条件 Normal working condition and mounting conditions

- 周围空气温度为：-5 ~+40，24小时内其平均值不超过+35；
- 海拔高度：不超过2000m；
- 大气条件：在+40℃时空气相对湿度不超过50%；在较低温度下可以有较高的相对湿度，最湿月的月平均最低温度不超过+25℃，该月的月平均最大相对湿度不超过90%，并考虑因温度变化发生在产品上的凝露；
- 污染等级：3级；
- 安装类别：3级；
- 安装条件：安装面与垂直面倾斜度不大于±5°。
- 冲击振动：产品应安装和使用在无显著摇动、冲击和振动的地方。
- Ambient temperature: -5 ~ 40，daily average over 35
- Altitude not more than 2000m;
- Ambient conditions: relative humidity not more than 50% at 40, if lower temperature humidity can be higher, on the month when maxi average humidity occurs the Temperature shall be not more than 25，on this month the maxi average humidity shall not more than 90%, and there has considered the mist covering the product
- Polluted class: 3 grade
- Installation class: 3 grade
- Mounting conditions: the mounting inclined angle shall not more than +5°
- Impact vibration: there shall have no severe vibration, impact and vibration.

适用范围 Application

DW17系列万能式断路器(以下简称断路器)具有结构紧凑、体积小、重量轻、系统性强、零部件互换性好。保护功能齐全，技术经济指标高。维护使用方便等特点。

断路器适用于额定工作电压至660V，50Hz电路，作电能分配和线路不频繁转换之用；对线路及电气设备的过载、欠电压和短路进行保护，并具有分级选择保护；能直接起动电动机，并保护电动机，发电机和整流装置等，免受过载，短路和欠电压等不正常情况的危害。

断路器技术性能符合IEC60947-2、GB14048.2标准。

DW17 series conventional circuit breaker (hereinafter referred to as circuit breaker) is featured with compact structure, small volume, light weight, strong systematicness, favorable interchangeability of components, complete protection functions, high technical economical index, convenient maintenance, easy operation, etc.

This circuit breaker is applicable to circuits of 50Hz with rated working voltage up to 660V, used for power distribution and infrequent switching of circuits; it protects the circuitry and electric equipment against overload, under-voltage or short-circuit, it also has function of grading selective protection; it is able to start the motor directly, and protect the motor, generator and rectifier unit against overload, short-circuit, under-voltage or other abnormal conditions.

Technical performances of circuit breaker are in accordance with the standards IEC60947-2 and GB14048.2.

主要技术参数 Main Technical data

断路器不同环境温度下的持续电流变动 Circuit Breaker different ambient temperature changes in the sustained current

断路器壳架等级额定电流 Rated frame current In(A)	额定电流 Rated current In(A)	不同环境温度下的持续电流变动A(防护等级为IP00) Different ambient temperature changes in the continuing current A (Protection rating IP00)					
		固定式			抽屉式		
		35	45	55	35	45	55
1900	630	630	630	630	630	630	630
	800	800	800	800	800	800	800
	1000	1000	1000	1000	1000	1000	1000
	1250	1250	1250	1250	1250	1250	1250
	1600	1600	1530	1460	1600	1600	1460
2900	1900	1900	1810	1720	1900	1720	1620
	2000	2000	2000	2000	2000	2000	2000
	2500	2500	2500	2400	2500	2400	2300
3900	2900	2900	2900	2900	2900	2900	2770
	3200	3200	3200	3200	3200	3200	3200
	3900	3900	3900	3900	3900	3900	3750

规格 Specification

序号 No.	分类 Classification	型号 Type	三极 Three pole								备注 Note			
			RDW17											
			630	800	1000	1250	1600	1605	2000	2500		2505	3200	3205
1	主回路 main circuit	AC	电压至380V Voltage to 380V											任选一种 Choose a
		AC	电压至660V Voltage to 660V											
2	操作方式 Operation Electric	手动 Manual	右侧直接操作 The right side of the direct operation											任选一种 Choose a
		正面直接操作 Positive direct operation												
		正面快速操作 Positive rapid operation												
3	电压脱扣器 voltage release	电动机操作 Motor operation												三种脱扣器只能选其中二种或选用双分励脱扣器 Release three of which can only be two kinds of election or selection of doublesub-LaiRelease
		电动机预储能带释能操作 Pre-motor energy release can be operated with												
		瞬时动作 Instantaneous action												
4	过电流脱扣器 Release overcurrent	延时动作 Delayed action												任选一种 Choose a
		分励脱扣器 Shunt release												
		闭锁电磁铁 Atresia Electromagnet												
		过载长延时及短路瞬时 Overload and short circuit instantaneous												
5	安装和接线 Installation and wiring	过载长延时及短中短延时 overload and short-short delay												任选一种 Choose a
		短路瞬时 Short-circuit transient												
		短路短延时 Short-circuit short delay												
		无过电流脱扣器 No over-current release												
6	机械联锁装置 Mechanical interlock device	固定式 Fixed												供用户选用 For users to choose
		水平联结 The level of connection												
		垂直联结 Vertical connection												
		抽屉式 Drawer												
6	机械联锁装置 Mechanical interlock device	水平联结 The level of connection												供用户选用 For users to choose
		垂直联结 Vertical connection												

DW17

系列万能式断路器

Series conventional circuit breaker



接线图和外形尺寸图 Wiring diagram and outline drawing

● 断路器控制线路接线端子位置见图
Terminal location of control circuit for breaker as Picture

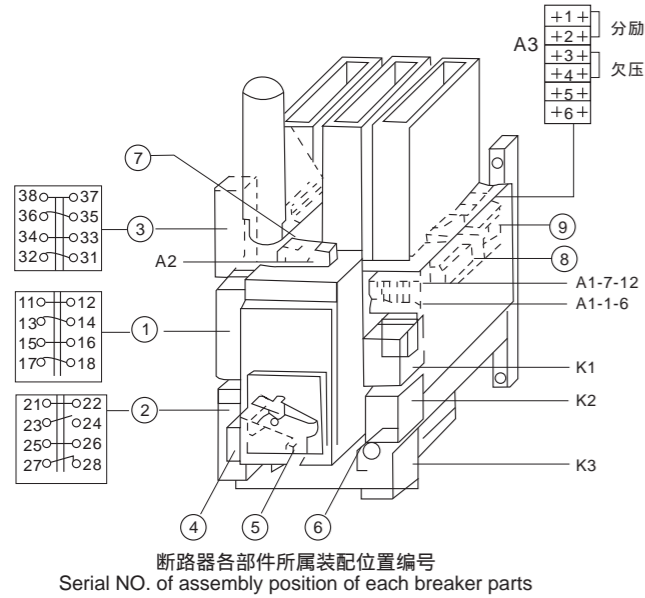

- 第一只HS5辅助触头DF1 . First HS5 auxiliary contact Df1
- 第二只HS5辅助触头DF2 second HS5 auxiliary contact DF2 (预储能23-24接点为动断) (terminals 23-24 for pre-charging are tripping off)
- 第三只HS5辅助触头DF3 Third HS5 auxiliary contact Df3
- 限位开关zh Limit switch
- S-脱扣器锁扣装置S-Lock device for release
- b-脱扣器锁扣装置b-Lock device for release
- 电动机传动带释能装置 motor driving strip with energy released device
- 欠电压脱扣器或第二个分励脱扣器 under-voltage release or second shunt release
- 第一个分励脱扣器或闭锁电磁铁 first shunt release or closing electromagnet

接线端尺寸(X向视图) Size of terminal (X-direction view)

DW17-630/800/1000

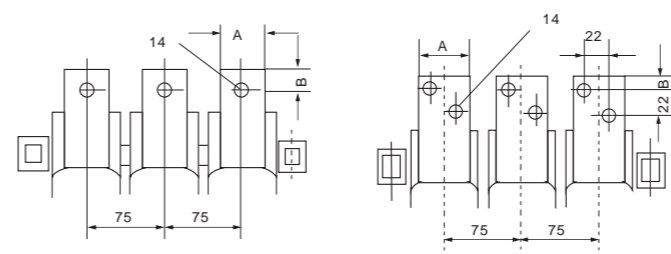

断路器型号	a	b	c	d	g	h	k
DW17-630	30	5	61	15	5	50	480
DW17-800/1000	40	8	71	20	8	60	500
DW17-1250	50	10	81	14	10	70	520
DW17-1600	50	20	81	14	15	70	520
DW-1605	60	20	81	14	20	70	520

垂直接线 (注意: 绝缘隔离板 Y)
Vertical connection (Notice: insulation separate plate)

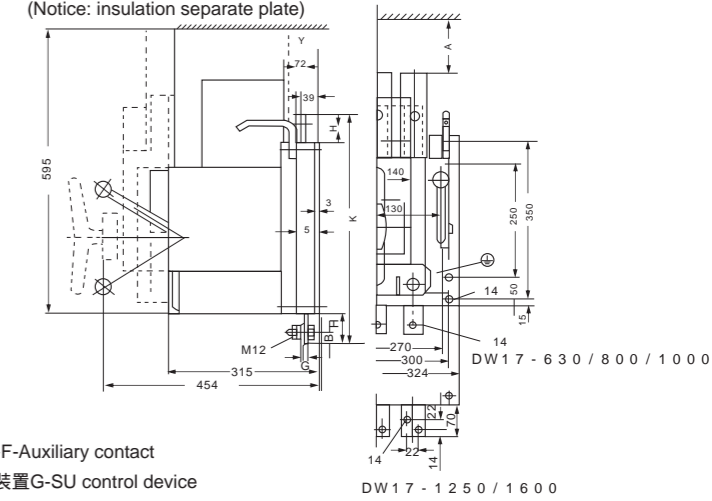

- F-辅助触头F-Auxiliary contact
- G-SU控制装置G-SU control device
- H-正面操作机构Front operating mechanism
- K-电动机操作机构Motor operating mechanism
- L-释放装置release device
- Y-用于垂直接线的绝缘隔离板(用户自备)
- Y-Insulation separated plate for vertical connection shall be provided by user

断路器安全距(包括飞弧距离)外形及安装尺寸Safe distance of breaker (including arcing distance), outline and mounting dimensions :

a. 断路器安全间距(包括飞弧距离)参见表 Horizontal fixed connection and safe distance of draw-out breaker mm

断路器型号 Breaker model	固定水平联结及抽屜式安全间距mm Horizontal fixed connection and safe distance of draw-out breaker mm				固定式垂直联结安全间距mm Vertical connection and safe distance mm			
	A	B	C	D	A	B	C	D
DW17-630/800/1250/1600	250	100	100	120	250	100	100	120
DW17-1605	250	100	100	120				
DW17-2000/2500/3200	350	100	100	120	500	100	100	120
DW17-2505/3205/4000/4005	350	100	100	120				

注: 1、所有带电零件与接地零件之间必须可靠绝缘; 2、本有为交流至380V数据。
Note: 1. All active parts shall be reliably insulated from earthing parts; 2. These are valid data under AC380V

b. DW17-630/800/1000/1250/1600/1605固定式断路器外形尺寸见图。
Outline of DW17-630/800/1000/1250/1600/1605 fixed type circuit breaker as drawing

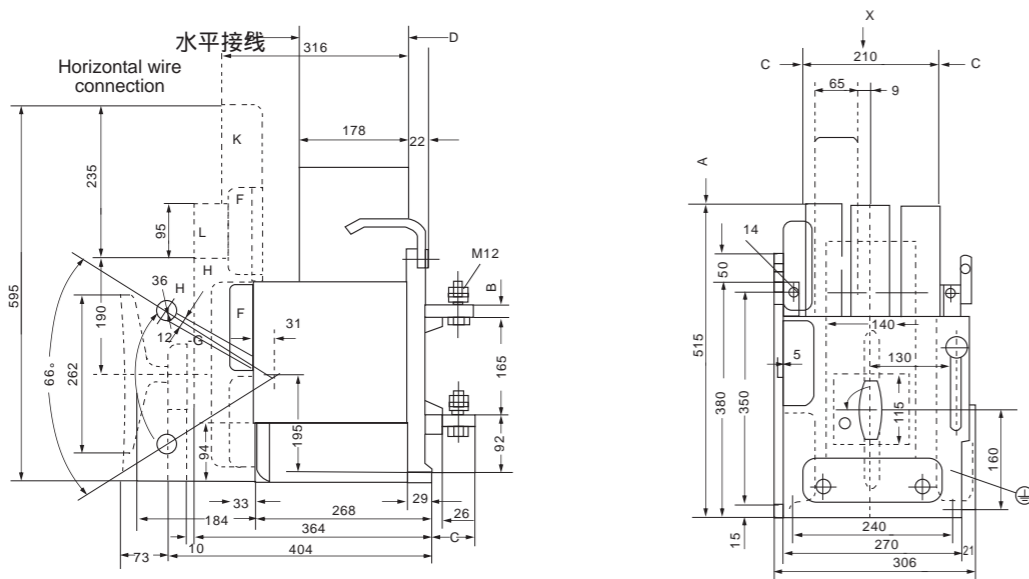

c. DW17-2000/2500/2505固定式断路器外形尺寸见图。

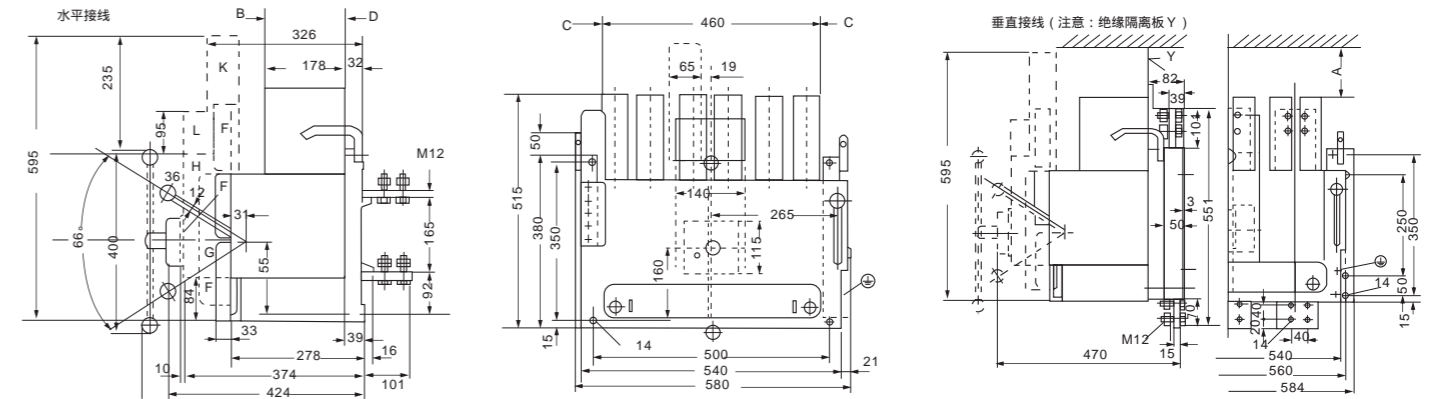

- F-辅助触头F-Auxiliary contact
- G-SU控制装置G-SU control device
- H-正面操作机构Front operating mechanism
- K-电动机操作机构Motor operating mechanism
- L-释放装置release device
- Y-用于垂直接线的绝缘隔离板(用户自备)
- Y-Insulation separated plate for vertical connection shall be provided by user

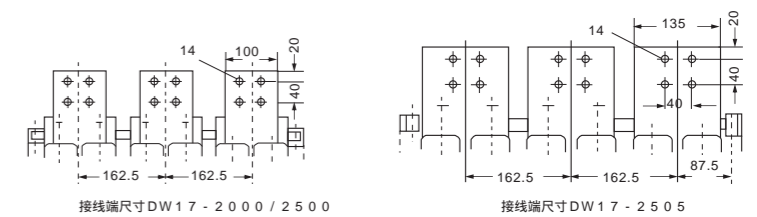

DW17

系列万能式断路器

Series conventional circuit breaker



d. DW17-3200/3205 固定式断路器外形尺寸见图。

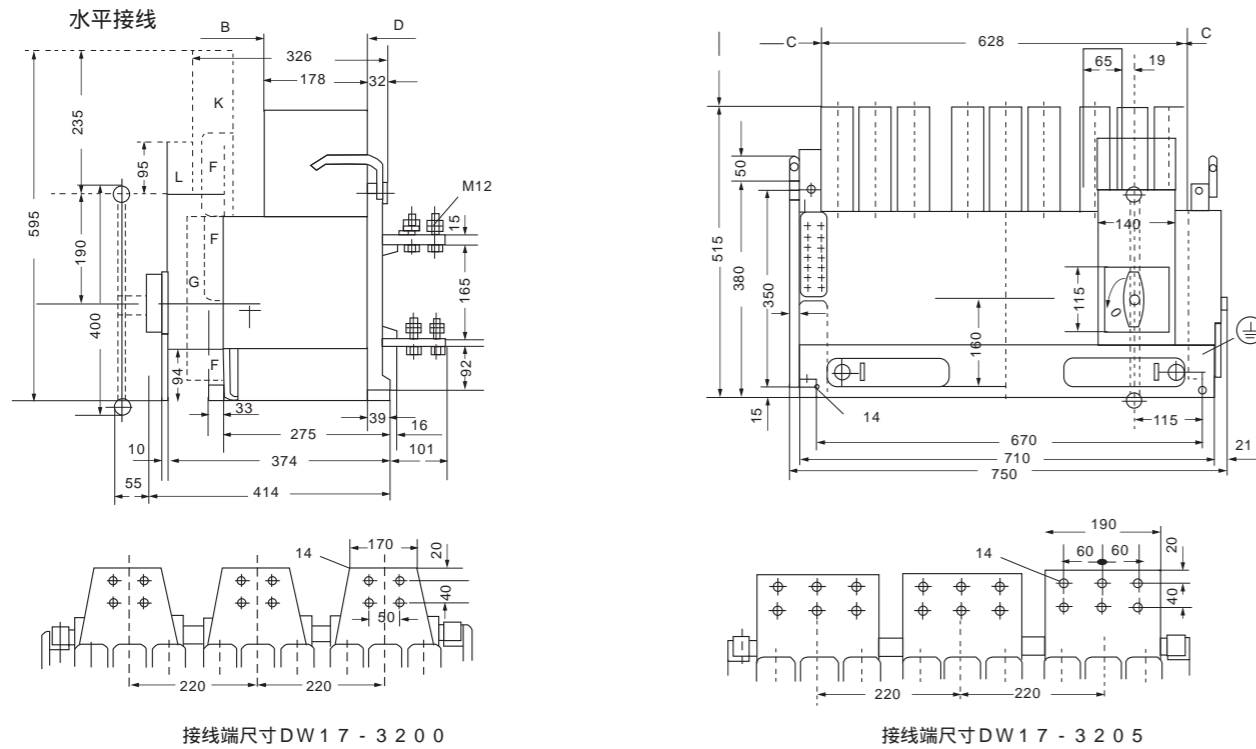

垂直接线 (注意: 绝缘隔板Y)

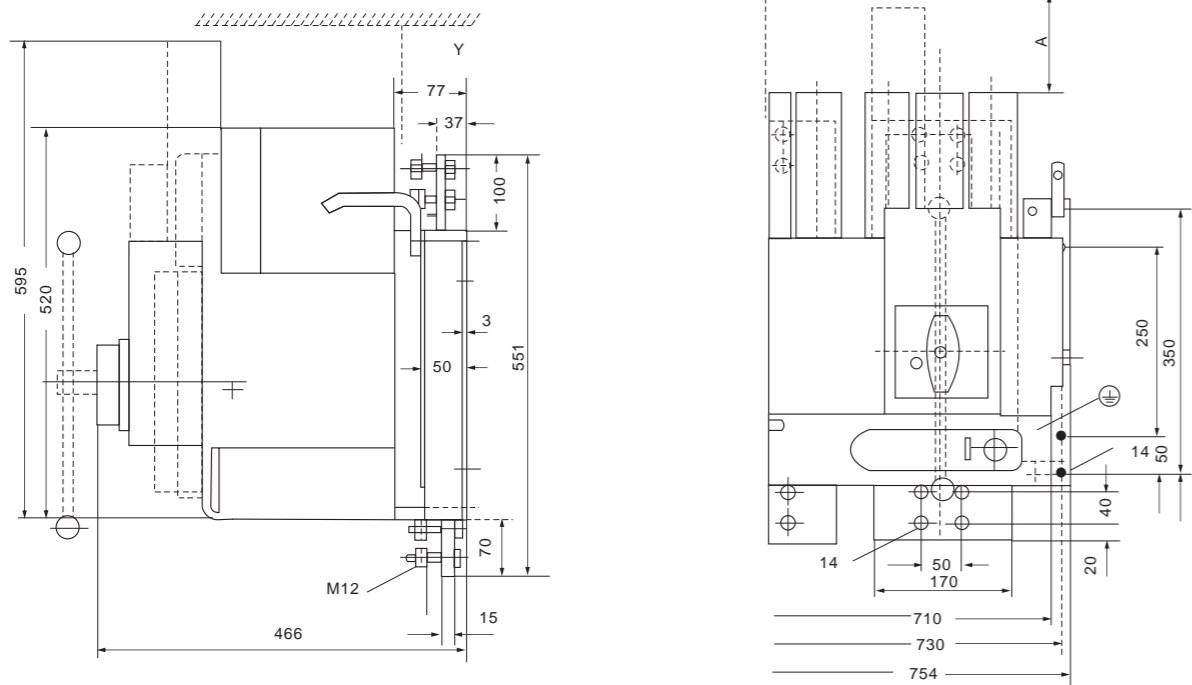

F-辅助触头
F-Auxiliary contact
G-SU控制装置
G-SU control device

H-正面操作机构
H-Front operating mechanism
K-电动机操作机构
K-Motor operating mechanism

L-释放装置
L-release device
Y-用于垂直接线的绝缘隔板(用户自备)
Y-Insulation separated plate for vertical connection shall be provided by user

mm单位:

e. DW17-630/800/1000/1250/1600 抽屉式断路器外形尺寸见图。

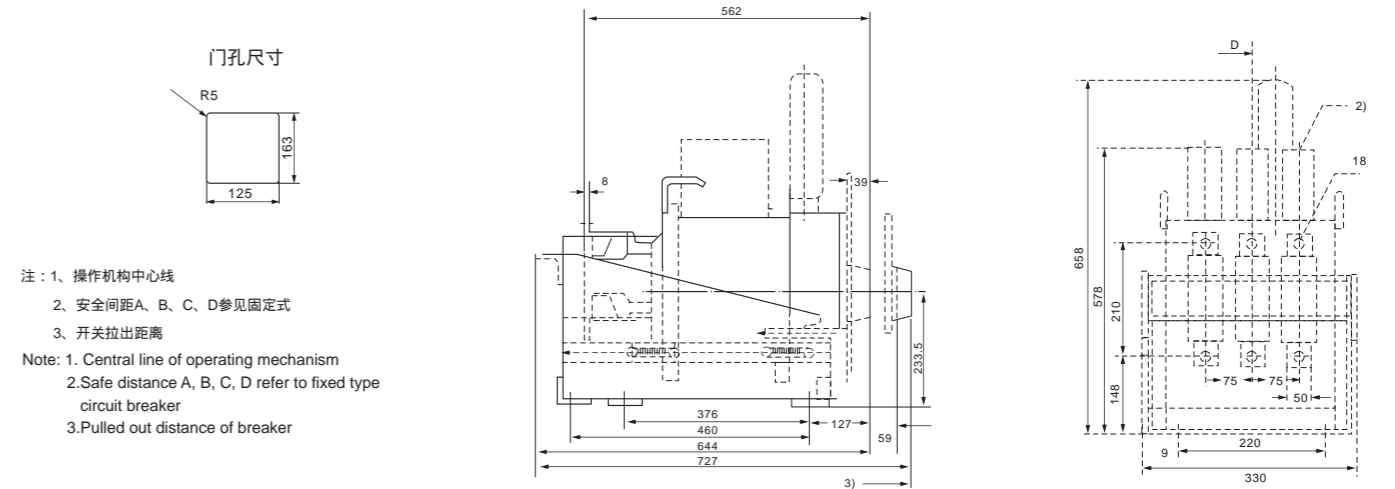

mm单位:

f. DW17-1605 抽屉式断路器外形尺寸见图。

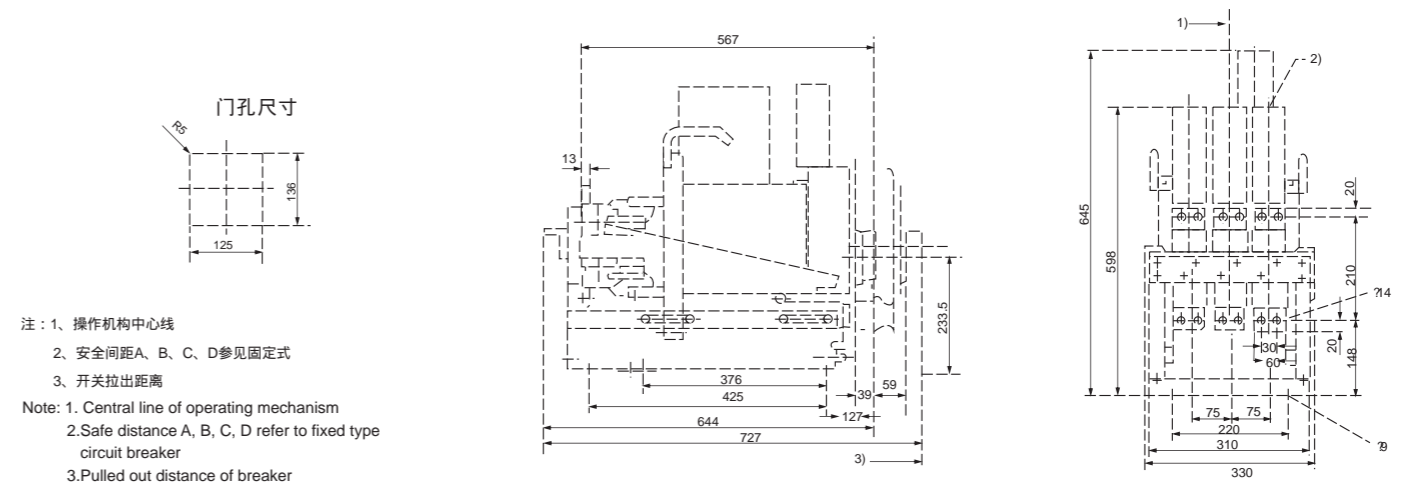

mm单位:

g. DW17-2000/2500 抽屉式断路器外形尺寸见图。

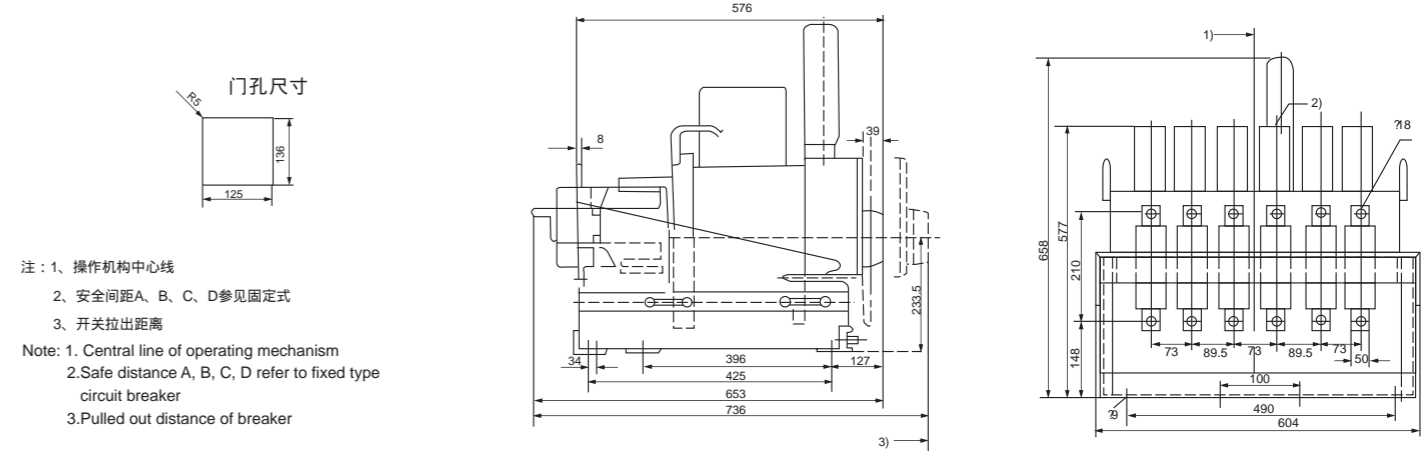

mm单位:

DW17

系列万能式断路器

Series conventional circuit breaker



h. DW17-2505 抽屉式断路器外形尺寸见图。

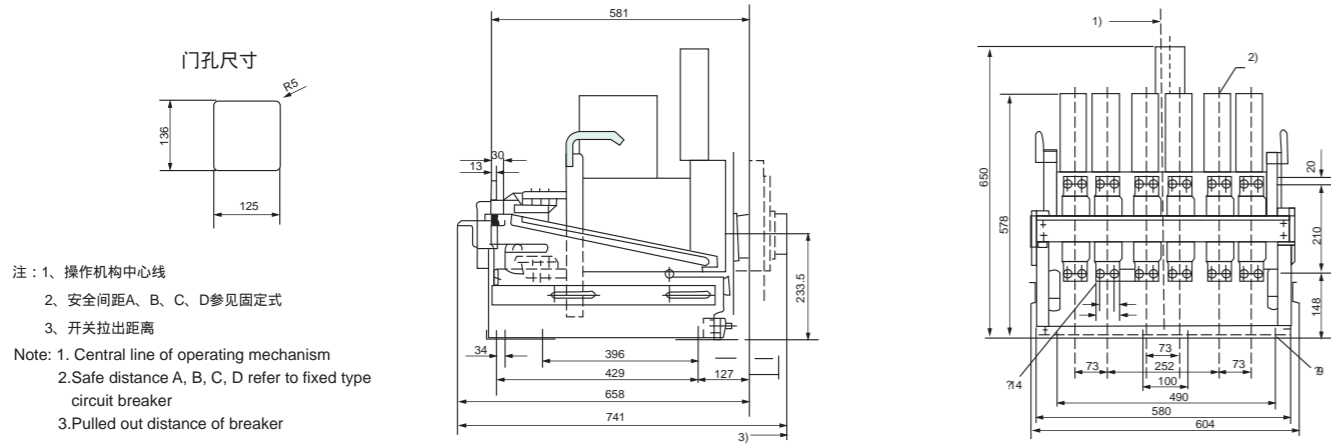

mm单位：

k. DW17-4000/4005 抽屉式断路器外形尺寸图。

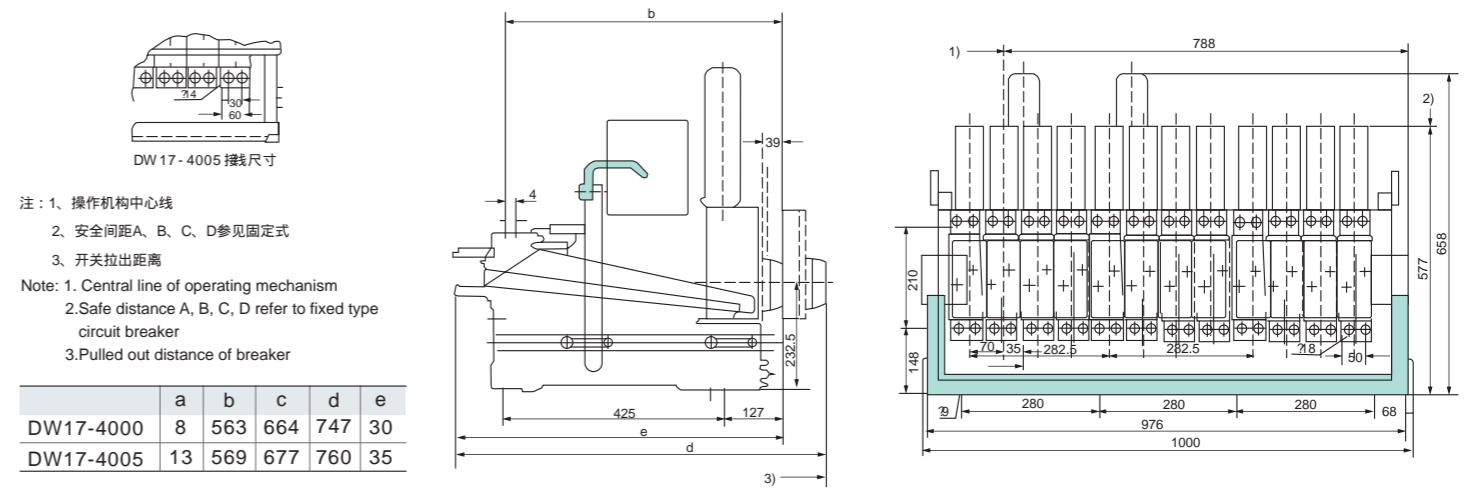

mm单位：

i. DW17-3200 抽屉式断路器外形尺寸见图。

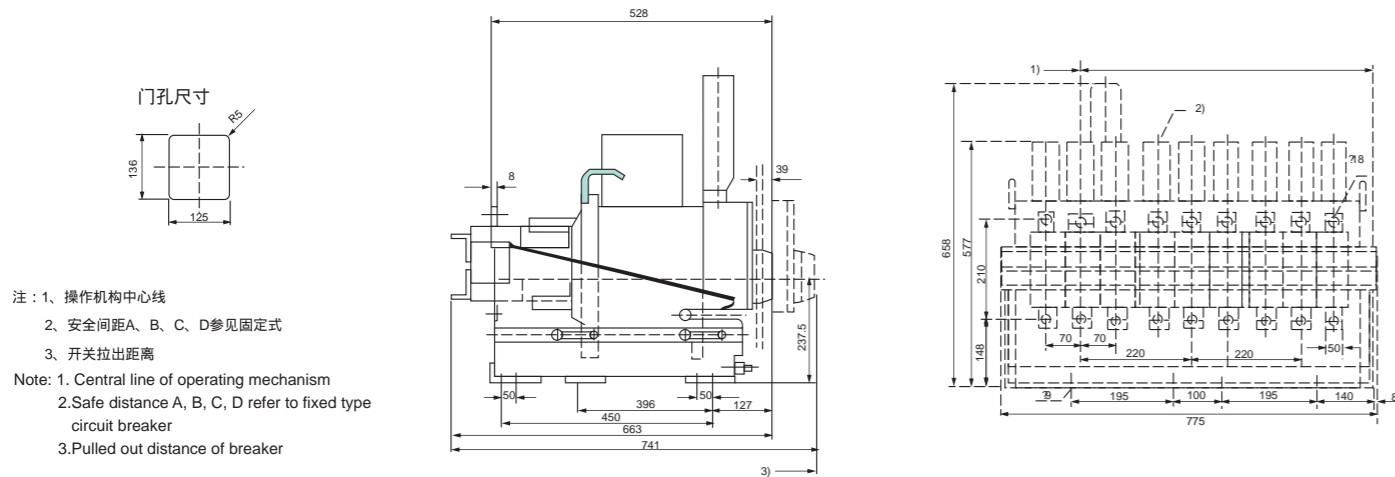

mm单位：

订货须知

订购断路器时，需注明下述各点：

- 断路器的型号，名称及数量；
- 额定电压及电流；
- 过电流脱扣器型式及额定电流；
- 电动操作机构型式及额定电压；
- 分励脱扣器型式及额定电压；
- 手动操作机构型式、辅助触头数量、安装型式、接线型式；
- 如需要W1、W2、W3、W4锁听到装置也需注明；
- 用户若有特殊要求，可经协商后签订协议或合同，按双方签订的协议或合同供货。

Order Notice

Please indicate the following details when to purchase the products

- Model, name, and qty of the breaker
- rated voltage and current
- Over-current tripping mode and its rated current
- Motor operating mechanism and its rated voltage
- Shunt release details and its rated voltage
- Hand operating mechanism, number of auxiliary contacts, assembly mode, and connection modes
- If W1, W2, W3, W4 locking device required, please indicate it as well
- If user has other special requirement, please discuss at firstly, then sign the contract, we will supply the goods according to the contract

j. DW17-3205 抽屉式断路器外形尺寸见图。

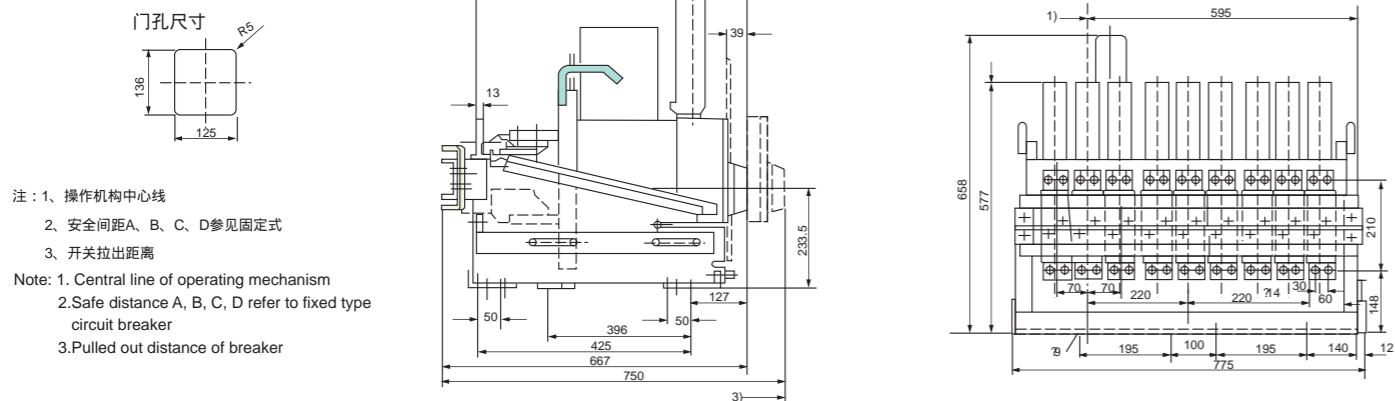

mm单位：

ZMW45

智能型万能式断路器

Overload and short circuit instantaneous



型号及含义 Type and meaning

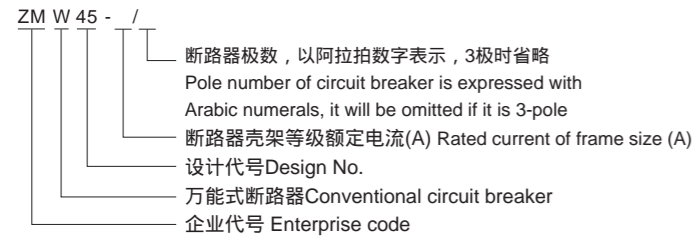

主要技术参数 Main Technical data

断路器的额定电流见表1
Circuit breakers rated current in Table 1

表1 Table 1

壳架等级额定电流 In m A	额定电流 I n A
2000	(400)630、800、1000、1250、1600、2000
3200	2000、2500、2900、3200、
4000	3200、3600、4000
6300	4000、5000、6300

断路器的额定短分断能力及短时耐受电流见表2, 断路器飞弧距离为“零(即断路器外无飞弧)”
Circuit breakers rated breaking capacity cut short and short-term tolerance of the current see table 2, circuit breakers arcing distance of a "zero (that is, outside the non-arcing circuit breaker)"

表2 Table 2

壳架等级额定电流 In m A	2000	3200	4000	6300	
额定极限短路分断能力 Rated limit short-circuit breaking capacity Icu(kA)O-CO	400V	80	100	120	
	690V	50	65	85	
额定短路接通能力 Rated short-circuit making capacity Ics(kA)O-CO	400V	176/0.2	220/0.2	264/0.2	
	690V	105/0.25	143/0.2	187/0.2	
额定运行短路分断能力 Rated service short-circuit breaking capacity Ics(kA)O-CO-CO	400V	50	65	80	
	690V	40	65	75	
额定短时耐受电流 Rated short-time withstand current Icw(kA)1S, 延时 time delay 0.4s, O-CO	400V	50	65	65/80(MCR)	85/100(MCR)
	690V	40	50	50/65(MCR)	65/75(MCR)

注: 表中分断能力上下进线相同。Note: breaking capacity indexes of upper and lower incoming lines are the same.

适用范围 Application

ZMW45系列智能万能式低压断路器适用于交流50Hz, 额定电压至690V及以下, 额定电流400A~6300A的配电网络中, 用来分配电能和保护线路及电源设备免受过载、欠电压、短路、单相接地等故障的危害。断路器具有智能化保护功能, 选择性保护精确, 能提高供电可靠性, 避免不必要的停电。同时带有开放式通讯接口, 可进行四遥, 以满足集控中心和自动化系统的要求。该断路器在海拔2000米时脉冲耐压8000V(不同海拔按标准修正, 最多不超过12000V)。该断路器、不带智能脱扣器及传感器可作隔离器用, 标示为 —/—。

断路器符合GB14048.2《低压开关设备和控制设备低压断路器》和IEC947-2《低压开关设备和控制设备 断路器》等标准。

ZMW45 series intelligent conventional circuit breaker is applicable for distribution network of AC50Hz with rated voltage up to and including 690V and rated current 400A~6300A, used to distribute electric energy and protect the power equipment against overload, under-voltage, short-circuit or single-phase grounding fault. This circuit breaker has intelligent protection function and accurate selective protection, it improves reliability of power supply and avoids unnecessary power failure. Meanwhile, it has open type communication interface, it is able to carry out four remote controls, satisfying requirements of control center and automatic system. Pulse withstand voltage of this circuit breaker at altitude 2000m is 8000V (it can be corrected for different altitudes according to the standard, but not over 12000V at most). This circuit breaker also can be used as disconnector when it is prepared without intelligent release or sensor, marked as —/—.

This circuit breaker is in accordance with GB14048.2 Low-voltage switchgear and controlgear-Low-voltage circuit breakers and IEC947-2 Low-voltage switchgear and controlgear-Circuit breakers.

断路器的最大耗损功率为360W。断路器在不同环境温度下额定持续电流变动见表3

Max dissipation power of circuit breaker is 360W. Rated continuous current change of circuit breaker under different ambient temperatures as shown in table 3.

表3 Table 3

环境温度	DW45	400A	630A	800A	1000A	1250A	1600A	200A
40		400A	630A	800A	1000A	1250A	1600A	2000A
50		400A	630A	800A	1000A	1250A	1600A	1900A
60		400A	630A	800A	1000A	1250A	1600A	1800A

注: 2500A及以上降容系数为0.9, 其中6300A中的4000A不降容。Note: derating factor for 2500A above is 0.9, and the capacity does not fall at 4000A within 6300A.

正常工作条件和安装条件 Normal working condition and mounting conditions

- 周围空气温度为: -5 ~+40 , 24小时内其平均值不超过+35 ;
- 海拔高度: 不超过2000m;
- 大气条件: 在+40 时空气相对湿度不超过50%; 在较低温度下可以有较高的相对湿度, 最湿月的月平均最低温度不超过+25 , 该月的月平均最大相对湿度不超过90%, 并考虑因温度变化发生在产品上的凝露;
- 污染等级: 3级;
- 安装类别: 3级;
- 安装条件: 安装面与垂直面倾斜度不大于±5°。
- 冲击振动: 产品应安装和使用在无显著摇动、冲击和振动的地方。
- Ambient temperature: -5 ~ 40 , daily average over 35
- Altitude not more than 2000m;
- Ambient conditions: relative humidity not more than 50% at 40, if lower temperature humidity can be higher, on the month when maxi average humidity occurs the temperature shall be not more than 25 , on this month the maxi average humidity shall not more than 90%, and there has considered the mist covering the product
- Polluted class: 3 grade
- Installation class: 3 grade
- Mounting conditions: the mounting inclined angle shall not more than +5°
- Impact vibration: there shall have no severe vibration, impact and vibration.

外形及安装尺寸 Outline & installation size

Z M W 4 5 - 2 0 0 0 A 固定式断路器安装尺寸、外形尺寸

mm单位:

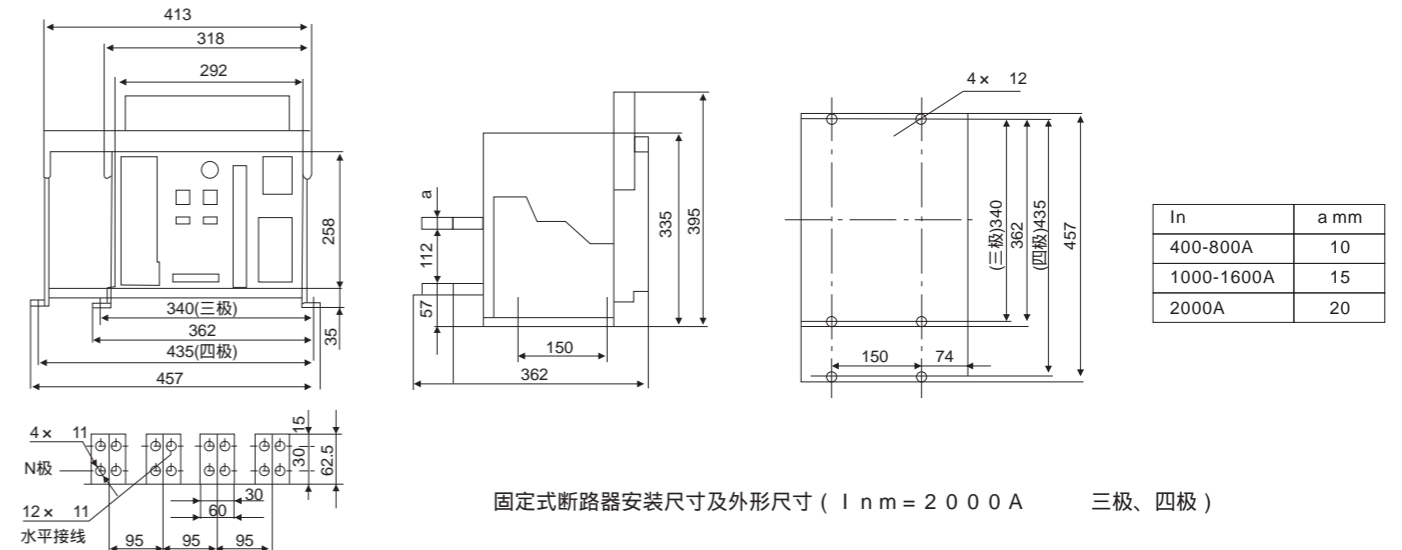

ZMW45

智能型万能式断路器

Overload and short circuit instantaneous



ZMW45 - 3200A 固定式断路器安装尺寸、外形尺寸

mm单位:

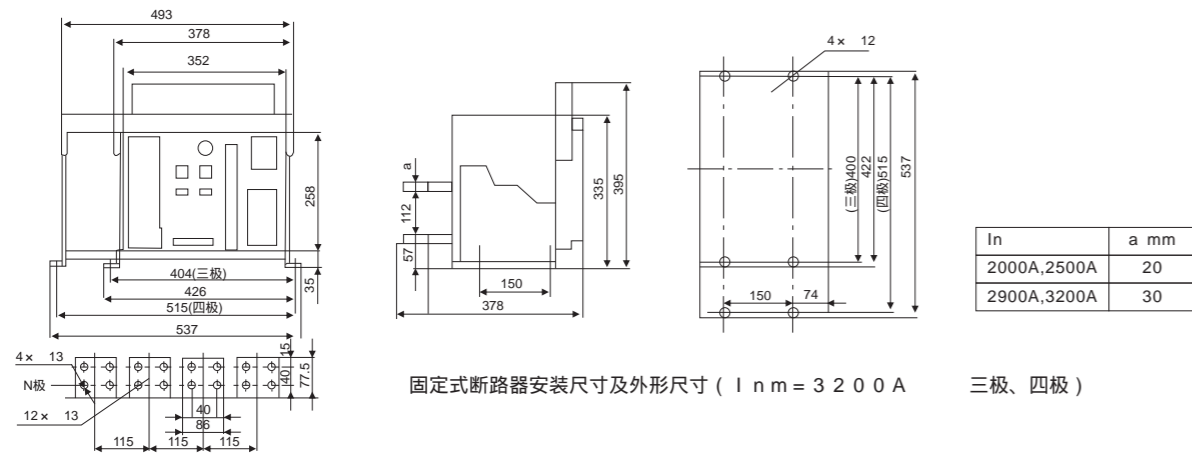

ZMW45 - 6300A 固定式断路器安装尺寸、外形尺寸

mm单位:

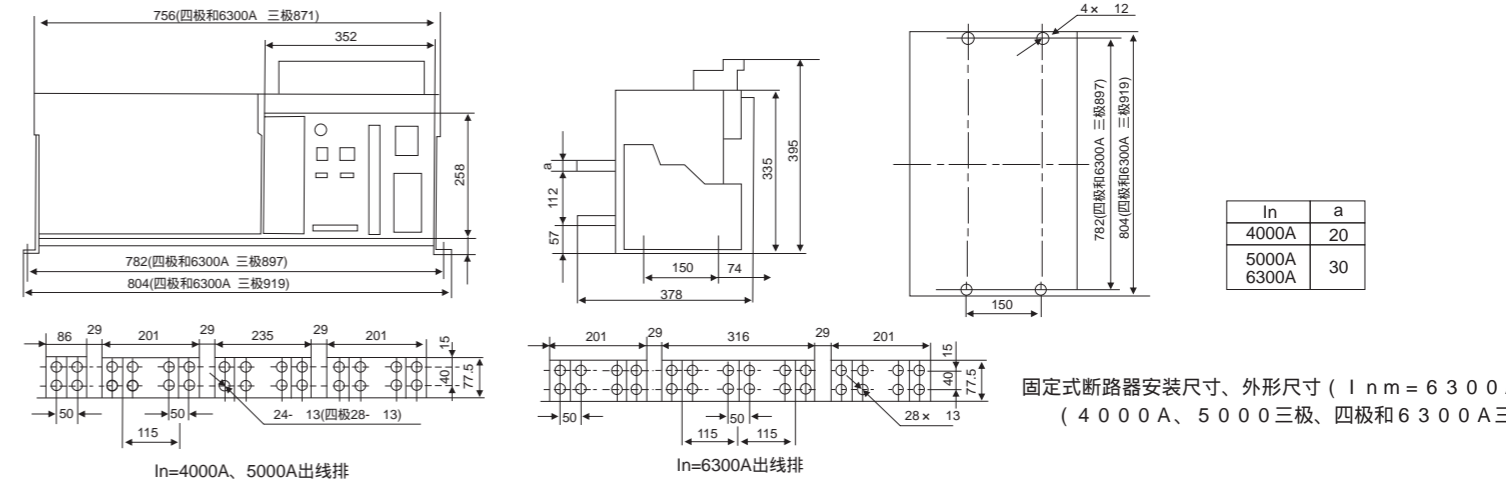

ZMW45 - 4000A 固定式断路器安装尺寸、外形尺寸

mm单位:

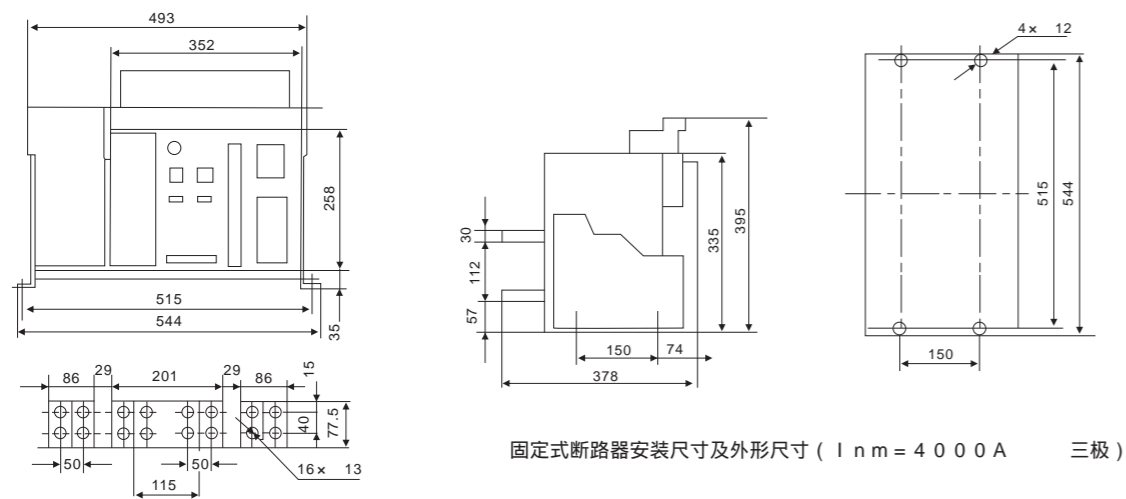

ZMW45 - 2000A 抽屉式断路器安装尺寸、外形尺寸

mm单位:

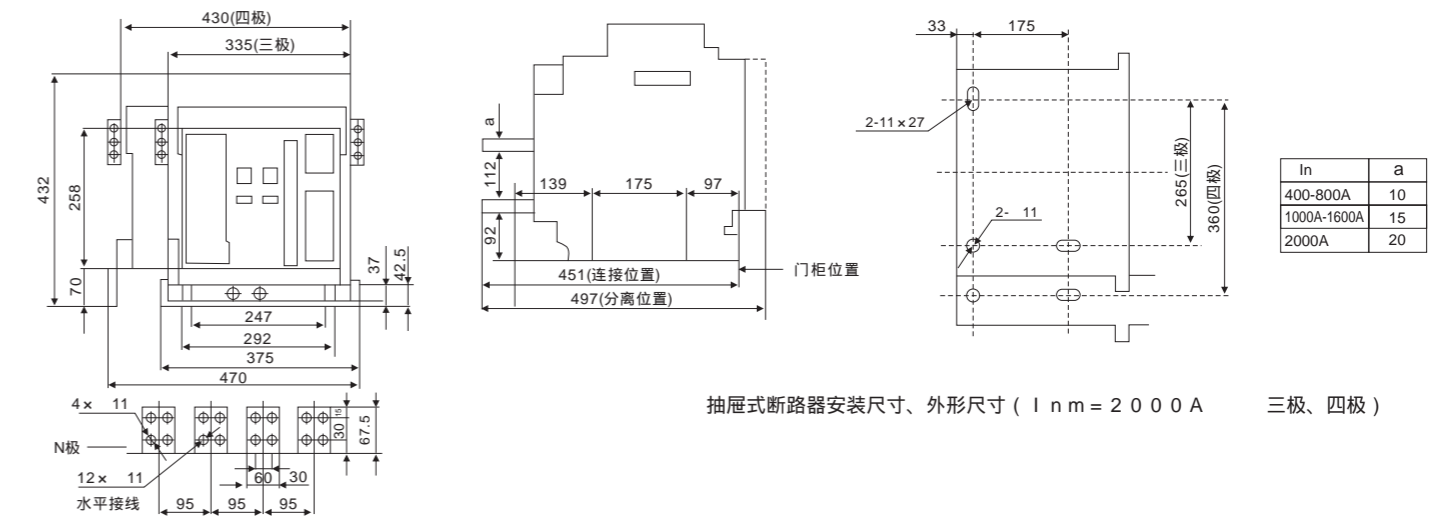

ZMW45 - 4000A (四极) 固定式断路器安装尺寸、外形尺寸

mm单位:

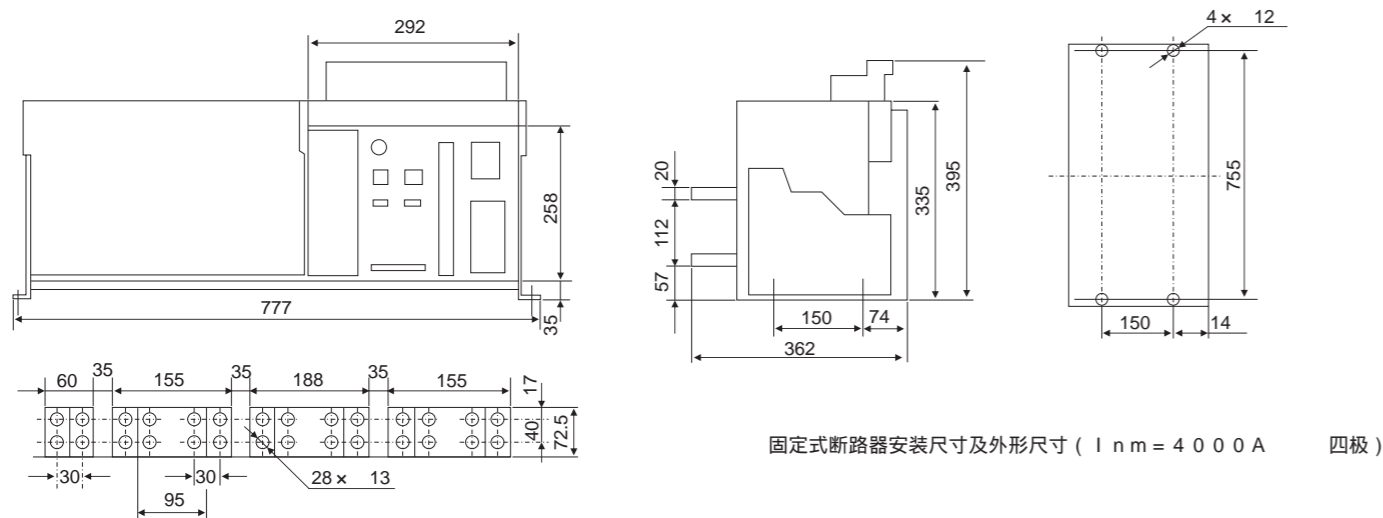

ZMW45 - 3200A 抽屉式断路器安装尺寸、外形尺寸

mm单位:

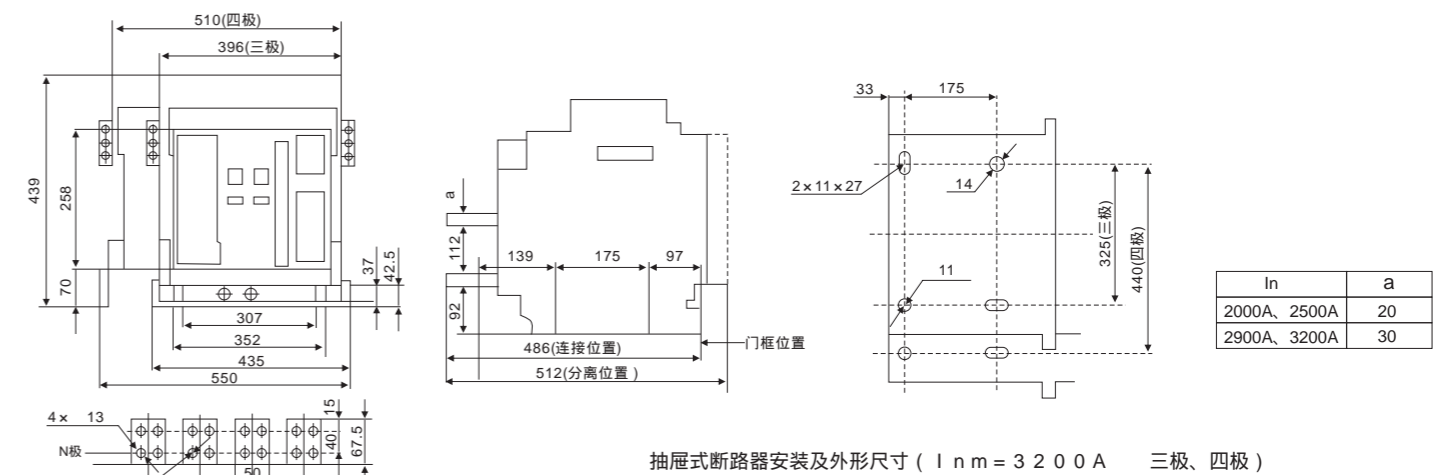

ZMW45

智能型万能式断路器

Overload and short circuit instantaneous



ZMW45 - 4000A 抽屉式断路器安装尺寸、外形尺寸

mm单位:

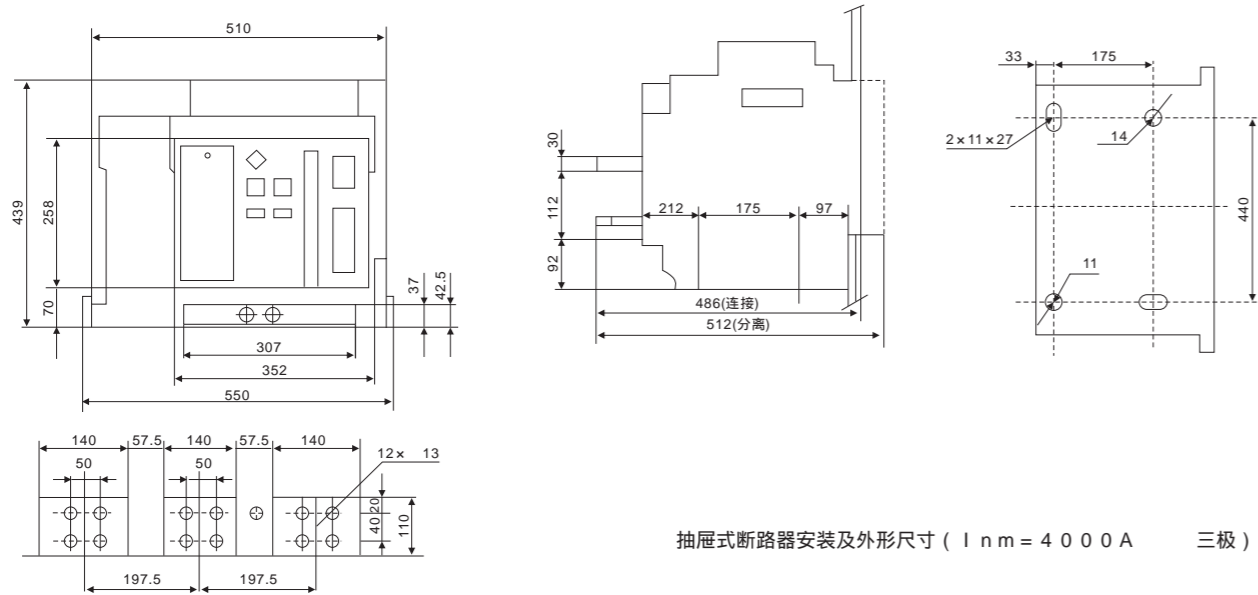

面板钻孔安装尺寸见图

mm单位:

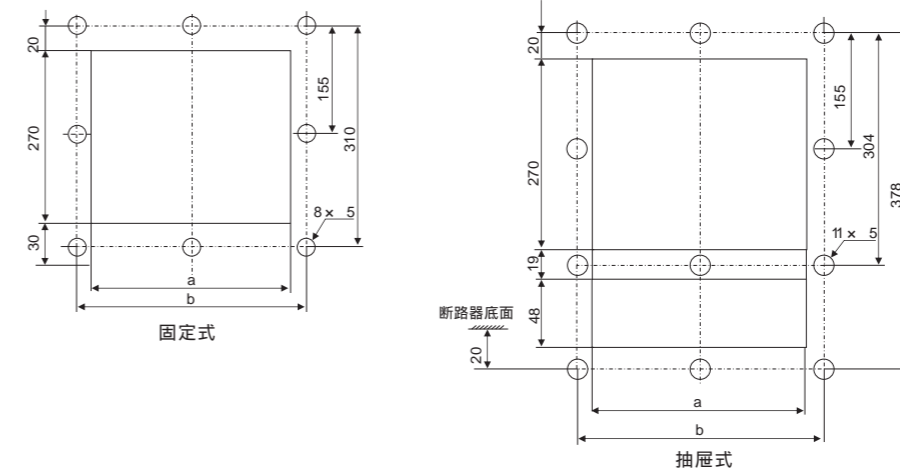

面板钻孔安装尺寸

型号	a	b
MYW1-2000	306	346
MYW1-3200-6300	366	406

ZMW45 - 4000A (四极) 抽屜式断路器安装尺寸、外形尺寸

mm单位:

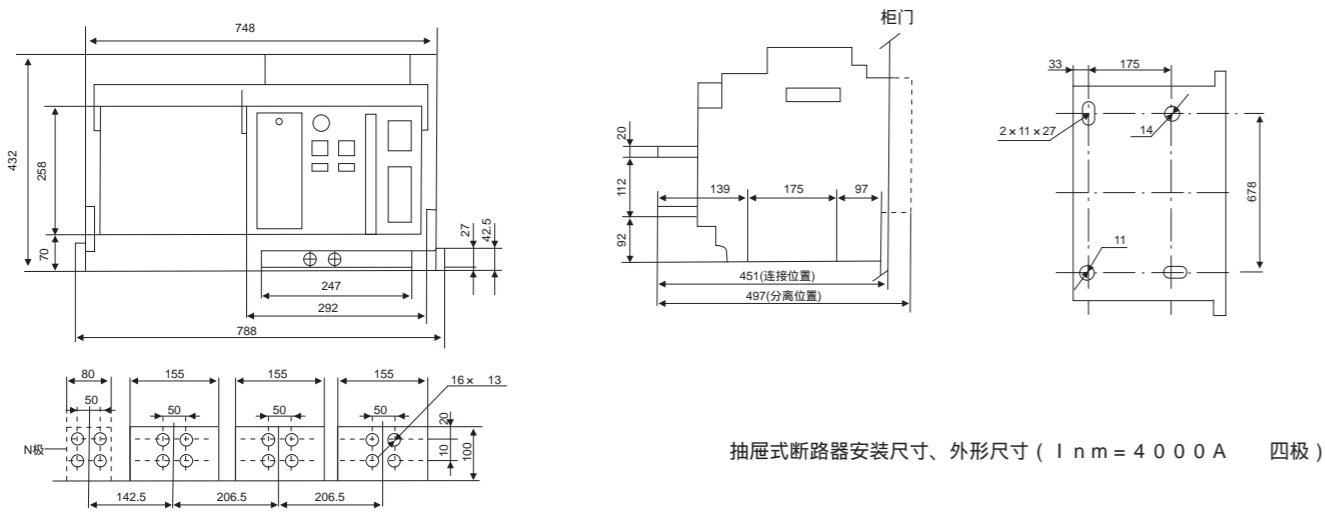

断路器的联锁机构见图

mm单位:

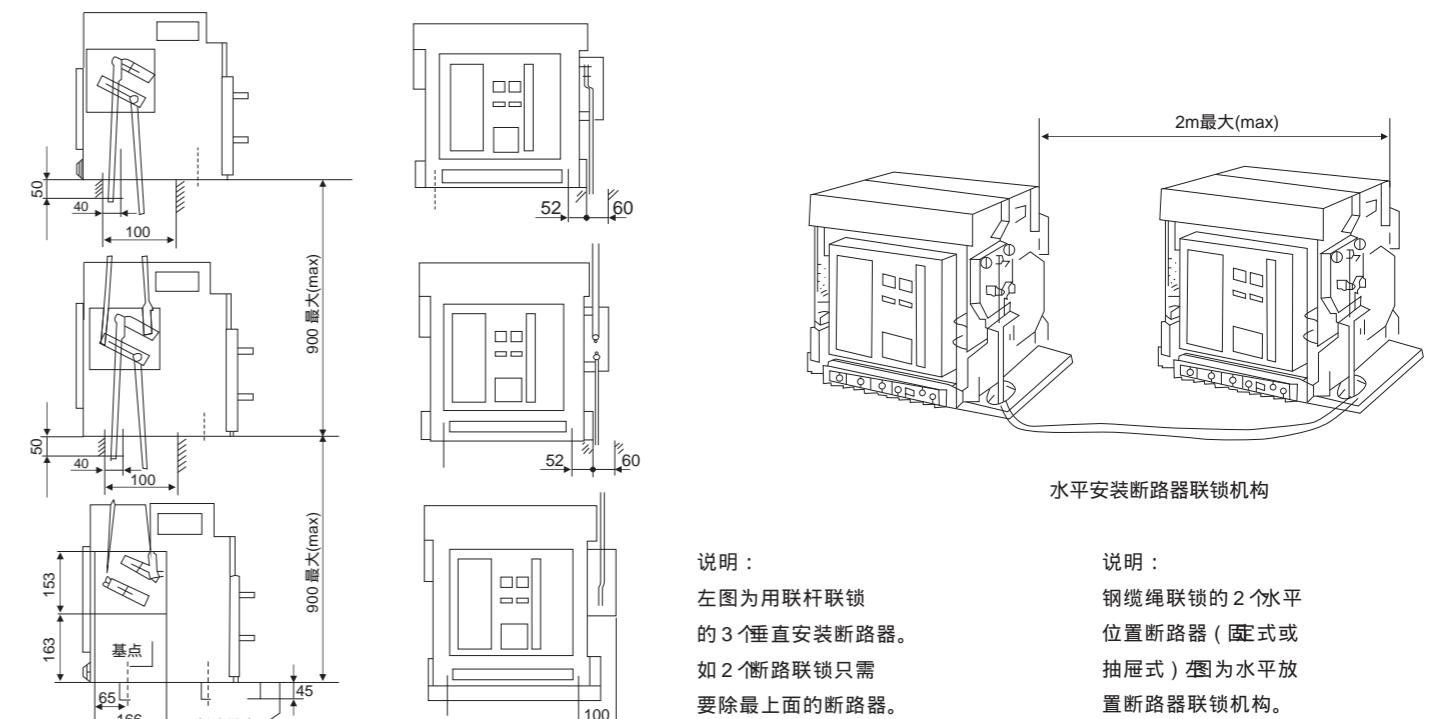

ZMW45 - 6300A 抽屜式断路器安装尺寸、外形尺寸

mm单位:

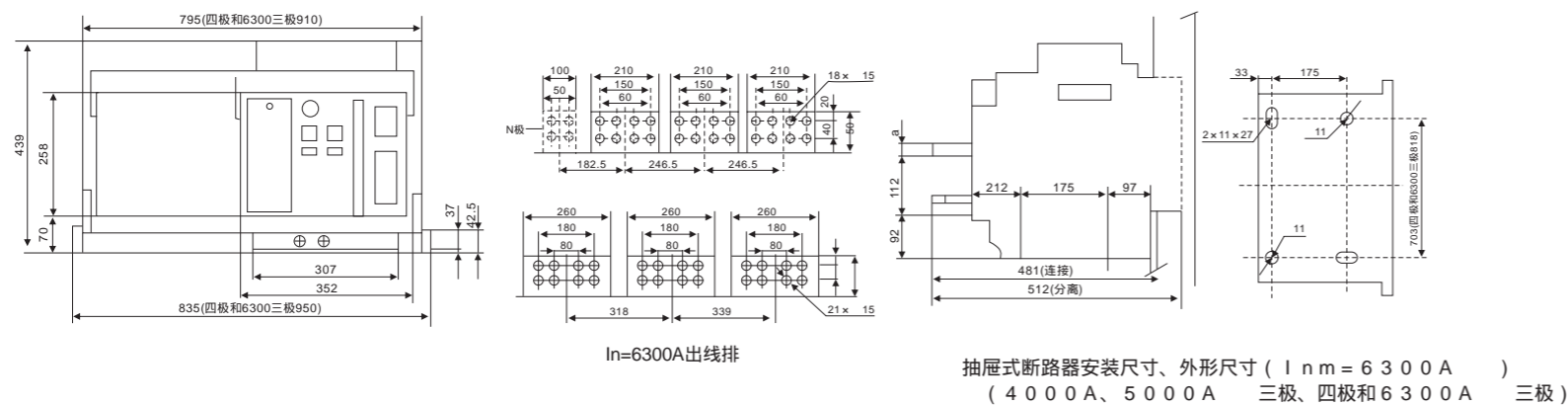

ZMW50-1000 智能型万能式断路器

Overload and short circuit instantaneous



型号及含义 Type and meaning

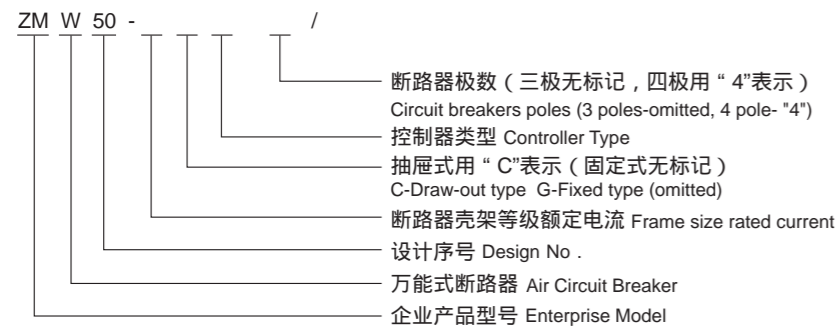

分类 Classification

- 按使用类别分：A类 (非选择型) B类 (选择型)
- 安装方式：固定式 抽屉式
- 传动方式：电动机传动 手动
- 极数：三极 四极
- 脱扣器种类：智能型控制器 分励脱扣器 欠电压瞬时 (或延时) 脱扣器
- 智能型控制器分类 (标准配置为M型智能型控制器)
 - a) ZMW50系列智能控制器采用编码开关、拨动开关的整定方式。按其保护特性可分为2L2、2L3、2L4三种基本类型外，还具有按钮整定方式 及数码管显示的M型智能型控制器及液晶显示的H型智能控制器。
 - b) 2L2(基本保护)：过载长延时+短路瞬时；2L3(选择性保护)：过载长延时+短路短延时 (定时限)+短路瞬时；2L4(选择性保护+接地保护)：过载长延时+短路短延时 (定时限)+短路瞬时+接地保护 (电流矢量和方式)。
 - c) M型智能控制器：采用按钮整定方式调整各种保护参数，数码管显示方式显示各种数据，保护功能多样化。
- 智能型控制器性能
 - a) 具有过载长延时 (反延时)、短路短延时 (定时限)、短路瞬动、单相接地等保护功能，可由用户自行设定，组成所需的保护特性；

适用范围 Application

ZMW50-1000智能型万能式断路器 (以下简称断路器)，用于交流50Hz，额定电压400V、690V，额定电流200~1000A的配电网中，主要用来分配电能和保护线路及电源设备免受过载、短路、欠电压、单相接地等故障的危害。在正常条件下可作线路的不频繁转换之用，也可作为电动机的不频繁启动及保护之用。该断路器具有多种智能化保护功能，选择性保护精确，能提高供电可靠性，避免不必要的停电。断路器具有隔离功能，

符号表示为“”。

断路器的技术性能符合GB14048.2《低压开关设备和控制设备 第2部分：断路器》。IEC60947-2《低压开关设备及控制设备 第2部分：断路器》等标准。

ZMW50-1000 conventional circuit breaker (hereinafter call "breaker") is suitably used in the distribution circuit of AC 50Hz, rated voltage 400V, rated current 200 ~1000A, to distribute electric power and protect circuit and equipment from overloading, short circuit, under-voltage, single phase earthing, residual current faults. At normal working conditions the breaker can be used to transfer the distribution lines or start the motor non-frequently. The breaker provides the intelligent protection function and high precise selective protection, improve the reliability of power supply, and prevent unnecessarily cutting off power supply. The breaker has isolation function,

Use the symbol "" to indicate.

The breaker complies with the standards of GB14048.2 and IEC 60947-2 "Low-voltage switchgear and controlgear Part 2: Low-voltage circuit breakers"

- b) 单相接地保护性能：根据三相电流和中性极电流矢量和进行保护；
- c) 显示功能：负载电流光柱、MCU运行监视；
- d) 报警功能：过载预警；
- e) 自检功能：过热保护，微机自诊断、A/D转换自检、E2PROM自检；
- f) 试验功能：校验控制器的动作特性；
- g) 故障记忆功能：检查线路或设备的发热程度，检查故障电流、延时时间及故障状态；
- h) MCR和越限跳闸功能：断路器主回路中存在故障电流时，断路器在合闸瞬间，只要主电路有故障电流且大于短延时整定值时，断路器应瞬时动作。2L2无此功能；
- i) 整定功能：利用编码开关、拨动开关或按钮的方式进行电流、时间整定；
- j) 触点输出功能：断路器具有四组触点输出：过载报警、接地报警、自诊断报警、OCR故障脱扣报警。

- According to Use Category:
Class A (non-selectable) Class B (Selective)
- According to installation mode :
a .Fixed type b .Draw-out type
- According to No of poles :3 pole ,4pole
- According to operation mode :
a .Motor driven operation
b .Manual operation (for repair, maintenance)
- Trip unit types :
Intelligent controller, Instantaneous (delay)
undervoltage release, Shunt release.
- Intelligent Controller classification (standard configuration for M-type intelligent controller)
 - a) ZMW50 series intelligent controller adopted coding switch, dial switch to adjust and set, its protective characteristics divided into three basic kinds: 2L2, 2L3, 2L4, also have M type intelligent controller to be set and adjusted by pushbutton and displayed by LED, and H type controller with LCD display.
 - b) 2L2 (basic protections): overloading long time delay trip + short circuit instantaneous tripping; 2L3 (selective protection): overloading long time delay trip + short circuit short delay tripping (definite time) +short circuit instantaneous tripping; 2L4(Selective protection and earthing protection): overloading long time delay trip + short circuit short delay tripping (definite time) +short circuit instantaneous tripping + earthing protection (vector sum-up of currents)
 - c) M type intelligent controller: use pushbutton to adjust and set the protective parameters, LED display the data, protection functions are diversified.
- Performances of intelligent controller.
 - a) Te protections of overloading long time delay (inverse time delay), short circuit short delay (definite time), short circuit instantaneous tripping, single phase earthing and etc, these functions can be selected by user to form the right protection system that user need.
 - b) Single phase earthing protection: take action on basis of the vector sum-up of three-phase current and neutral line current.
 - c) Display function: Load current, MCU running monitor
 - d) Alarm function: alarm for overloading
 - e) Self-detection function: overheating protection, microcomputer self-diagnosed, A/D converter self-detection, E2PROM self-detection.
 - f) Test function: check the tripping characteristics of controller.
 - g) fault memorization function: check the heating degree of line or equipment, check fault current, delayed time and fault status;
 - h) MCR and over-limit tripping function: when main loop of breaker has fault current, at the moment of breaker being closed, once the fault current is larger than setting value of short time delay tripping current, the breaker shall trip instantaneously. 2L2 has no this function.
 - i) Setting function: use coding switch, dial switch or button to adjust current, and delay time
 - j) Contact output function: the breaker has four pairs of contacts: alarm for overloading, alarm for earthing, alarm for self-diagnosed fault, alarm for OCR fault tripping

ZMW50-1000

智能型万能式断路器

Overload and short circuit instantaneous



正常工作条件 Normal working condition

- 周围空气温度：上限不超过+40℃；下限不低于-5℃；24h的平均值不超过+35℃；
注：1、下限值为-10℃或-25℃的工作条件，在订货时用户须向制造厂申明；2、上限值超过+40℃或下限值低于-25℃的工作条件，用户应与制造厂协商。
- 海拔：安装地点海拔不超过2000m。
- 大气条件：大气相对湿度在周围空气温度为+40℃时不超过50%，在较低温度下可以有较高的相对湿度，最湿月的平均最大相对湿度为90%，同时该月的月平均最低温度为+25℃，并考虑到因温度变化发生在产品表面上的凝露。
- 污染等级：3级
- 安装类别：断路器主电路的安装类别为Ⅲ类，辅助电路的安装类别除了欠电压脱扣器线圈、电源变压器初级线圈与断路器的主电路相同外，其余均为Ⅱ类。
- 使用类别：B类
- 安装条件：断路器应按安装使用说明书的安装要求进行安装。断路器的垂直倾斜度不超过5°。

- When the ambient air temperature is -5℃~+40℃, the mean value is no greater than +35℃ with in 24 hours.
Note: if the upper limit is higher than +40℃ or lower limit lower than -5℃ in work, discussions shall be made between the user and the manufacturer.
- Altitude: not higher than 2000m for the installation site.
- When the ambient air temperature is +40℃, the relative humidity of the air shall not be higher than 50%; a higher relative humidity is allowed at a lower temperature; special measures shall be taken for the condensation occasionally produced due to temperature change.
- Degree of Pollution: III
- The installation category of the breaker main circuit is IV; The installation category of the control circuit and auxiliary circuit is III, apart from the similarity between the under voltage release coil and the intellectual controller's power transformer primary coil and the breaker;
- Use Category :B type
- Installation conditions: the mounting inclined angel shall not more the +5°

主要技术参数 Main Technical data

- 断路器的额定电流见表1 Circuit breakers rated current (see Table 1)

表1 Table 1

壳架等级额定电流Inm A Frame size rated current	额定电流In A Rated Current	控制器额定电流In(A) Rated controller current
1000	200、400、630、800、1000	200、400、630、800、1000

- 断路器的额定绝缘电压690V；额定工作电压400V、690V。Circuit breakers rated insulation voltage 690V; rated working voltage of 400V, 690V.
- 断路器的额定短路接通能力应不小于2.1Icu。Rated short circuit making capacity of breaker shall not be less than 2.1Icu.
- 断路器的额定短路分断能力及短时耐受电流见表2。Rated short circuit breaking capacity and short time withstand current of the breaker as table 2

表2 Table 2

壳架等级 额定电流 Inm(A) Frame size rated current	额定极限短路分断能力 Icu(kA)cos Rated ultimate short-circuit breaking capacity	额定运行短路分断能力 Ics(kA)cos Rated short-circuit breaking capacity	额定短时耐受电流 Icw(kA)cos Rated short time withstand current		飞弧距离 Arcing distance	进线方式 Connection
			380(400)V			
			短时1s 延时0.25s Short time 1s Delay 0.25s	短时0.5s 延时0.25s Short time 0.5s Delay 0.25s		
1000	42	30	20	30	零飞弧 "zero" (namely no arc)	上进线或下进线 Upper wires or Lower wires

注：Ue=690V，Icu=20kA。

- 智能控制器保护特性 Protection characteristic of the Intelligent controller

- 1) 智能控制器的整定值及误差见表3。Controller Current setting & Accuracy (see table 3)

表3 Table 3

长延时 Long delay	短延时 Short delay		瞬时 Instantaneous		接地故障 Ground fault	
Ir1	Ir2	误差 Accuracy	Ir3	误差 Accuracy	Ir3	误差 Accuracy
(0.4~1)In	(3~10)In	±10%	(10~20)In	±15%	(0.2~0.8)In	±10%
			(3~10)In			

注：瞬时(3~10)In为2L2型脱扣器的整定值。

Note: Instantaneous tripping current (3~10)In is the setting value of 2L2 type release.

- 2) 智能控制器长延时过电流保护反时限动作特性为 $2TL = 1(5Ir1)^2tL$ (式中tL:长延时5Ir1时整定时间, Ir1:长延时整定电流, TL长延时动作时间), 动作时间误差其时限误差为±10%。
- 3) 智能控制器短延时过电流保护特性为定时限特性, 其延时时间为0.2s(L型控制器)、0.4s, 可返回时间为0.21s, 其时限误差为±10%。
- 4) 接地故障保护动作特性为定时限, 其延时特性符合表5, 其时限误差为±15%。
- 5) 断路器过电流保护特性、接地故障保护特性曲线见图所示。

- 2) Inverse time delay tripping characteristics for long time delay over-current protection is $I^2TL=(1.5Ir1)^2tL$ (tL: setting time of long time delay tripping 1.5Ir1, Ir1: setting value of long time delay tripping, TL: tripping time of long time delay protection) Tripping time as table 4, time limit error: ±10%
- 3) Short time delay over-current protective characteristics of the controller is definite time tripping, time delay is 0.2s (L type controller), 0.4s, returnable time 0.21s, time limit error: ±10%
- 4) Earthing fault protection characteristics is definite time tripping, and complies with table 5, time limit error: ±15%
- 5) Over-current protective characteristics, earthing fault protection characteristics of breaker as Figure 1.



图1 Figure 1

表4 Table 4

I	动作时间 Action time			
1.05Ir1	> 2h不动作 No action			
1.3Ir1	< 1h不动作 No action			
1.5Ir1	30s	60s	120s	240s
2.0Ir1	16.9s	33.7s	67.5s	135s

注：1.5Ir1的时间由用户整定, 2.0Ir1的时间按 $I^2TL=(1.5Ir1)^2tL$ 计算。

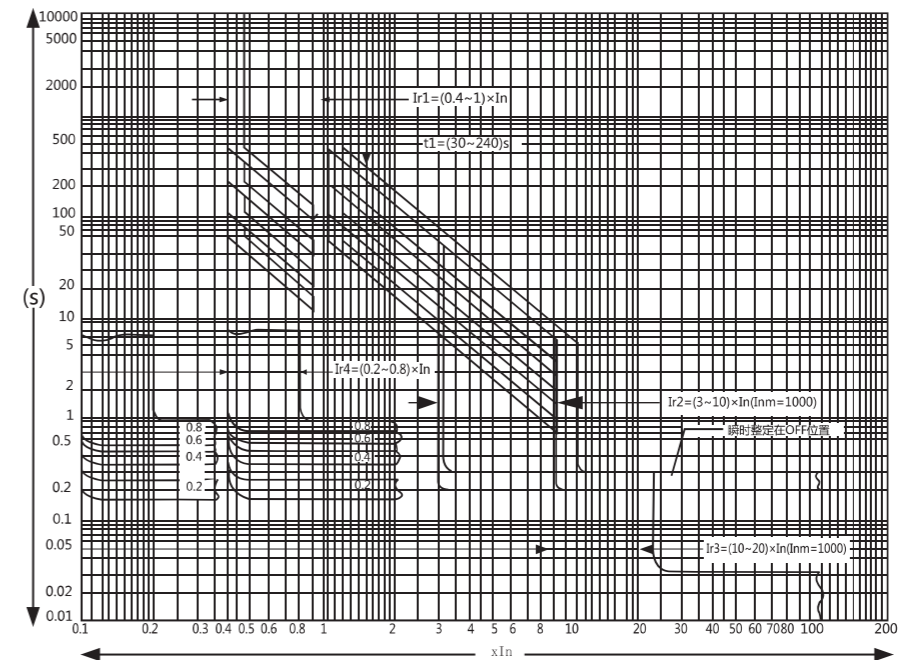
Note: the time of 1.5Ir1 set by user, time of 2.0Ir1 determined by calculation according to $I^2TL=(1.5Ir1)^2tL$

表5 Table 5

延时时间 Delay time	0.2s	0.4s	0.6s	0.8s
可返回时间 Time return	0.16s	0.36s	0.54s	0.72s

ZMW50-1000

智能型万能式断路器

Overload and short circuit instantaneous



6) 断路器的操作循环次数见表6 Operation performances of breaker are shown by operation cycles(see table 6)

表6 Table 6

壳架等级额定电流 Inm(A) Rated frame size current	每小时操作循环次数 Operating cycles per hour	操作循环次数 Operating cycles		
		通电 Energize	不通电 Not energized	总数 Total
1000	20	500	4500	5000

7) 断路器控制电路电源电压见表7。 Supply voltage circuit breaker control(see table 7)

表7 Table 7

名称 Description	额定电压 Rated voltage	
	交流AC (V)	直流DC (V)
欠电压脱扣器 (Ue) Undervoltage release		-
分励脱扣器 (Us) Shunt release		-
闭合电磁铁 (Us) Closing electromagnet	220 (380) 380 (400)	110 220
操作电动机 (Us) Operation counter		-
控制器电源电压 (Ue) Power voltage of controller		110 220 24

注：控制器工作电压为DC24V其变压器或电源模块一次侧可提供电压为AC380V、220V或50Hz或DC220V、110V。

Note: Operating voltage of controller is DC24V, input side of the transformer or power source module can be AC380V、220V (50Hz) or DC220V、110V

注：分励脱扣器在70%~100%Us范围内保证断开断路器；操作电动机在85%~110%Us范围内可靠完成储能，闭合电磁铁应在85%~100%Us范围内保证断路器可靠闭合。智能控制器应在85%~115%Ue范围内保证断路器可靠工作。

Note: the shunt release under 70%~110%Us shall open the breaker reliably, operating motor under 85%~110%Us can perform charging energy reliably, for closing electromagnet, the operating voltage within 85%~100%Us shall guarantee breaker being closed reliably. The controller shall be able to work within 85%~115%Ue safely and reliably

8) 断路器欠电压脱扣特性见表8。 Operating characteristic of Undervoltage release(see table 8)

表8 Table 8

类别 Type	欠电压延时脱扣器 Undervoltage time delay release	欠电压瞬时脱扣器 Undervoltage instantaneous release
脱扣器动作时间 Action time release	延时 time delay 1、3、5s	瞬时 Instantaneous
脱扣器动作电压值 Release operation voltage value	35%~70%Us	能使断路器断开 Reliable disconnect breaker
	35%	断路器不能闭合 Breaker can not be closed
在1/2延时时间内，当电源电压恢复到85%Ue Within 1/2 time delay, if power source recover up to 85% Ue	85%~110%Ue	断路器可靠闭合 Breaker can be reliably closed
	断路器不断开 Constantly open breaker	——

注：延时时间误差 ± 10% Note: Time delay Accuracy ± 10%

9) 辅助触头

9) Auxiliary contacts

9.1 辅助触头的约定发热电流 $I_{th} = 6A$ 。

9.1 Conventional thermal current of auxiliary contact $I_{th} = 6A$

9.2 辅助触头形式：标准配置为四常开三常闭，一组转换触头（如用户有特殊要求订货时应说明）。

9.2 The types of auxiliary contacts: standard arrangement: 4 NO + 3 NC, 1 pair of changeover contacts (Other than this, please indicate it when to book the product.)

9.3 辅助触头的非正常接通与分断能力见表9。

9.3 The abnormal making and breaking capacity of auxiliary contacts as table 9

表9 Table 9

使用类别 Use Category	额定控制容量 (Pe) Rated control capacity	额定工作电压 (Ue) Rated operating voltage	接通与分断 Making and breaking				通断操作循环次数和操作频率 Operating cycles and operating frequency		
			U/Ue	I/le	cos	T0.95(ms)	操作循环次数 Operating cycles	每分钟操作循环次数 Operating cycles per minute	通电时间 (s) Power-on time
AC-15	300VA	380V	1.1	10	0.3	——	10	6(与主回路操作频率相同) Operating frequency with the main circuit	0.5
DC-13	60W	220V	1.1	1.1	——	300			

9.4 辅助触头正常条件下的接通与分断能力见表10。 The normal making and breaking capacity of auxiliary contacts as table 10

表10 Table 10

使用类别 Use Category	额定控制容量 (Pe) Rated control capacity	额定工作电压 (Ue) Rated operating voltage	接通 Making				分断 Breaking			
			U/Ue	I/le	cos	T0.95(ms)	U/Ue	I/le	cos	T0.95(ms)
AC-15	300VA	380V	1	10	0.3	——	1	10	0.3	——
DC-13	60W	220V	1	1	——	300	1	1	——	300

9.5 辅助触头的不通电操作循环次数与断路器主回路相同。 Operation cycles of auxiliary contact without being electrified are same as main circuit of the breaker

9.6 断路器的最大操动力100N，抽屉式推进机构操作手柄的操动力不大于125N。

The maxi operating force for breaker is 100N, for push-in mechanism of the breaker (draw-out type) not exceed 125N

● 用户安装用铜排推荐见表11。 Copper busbar for installation recommended as table 11

表11 Table 11

额定电流In(A) Rated Current		200	400	630	800	1000
母排 Busbar	厚度(mm) Thickness	5	5	5	6	8
	宽度(mm) Width	30	30	40	50	50
	根数 Quantity	1	2	2	2	2

● 断路器的最大耗功率见表12。 Max. power loss of breaker as table 12

表12 Table 12

额定电流In(A) Rated Current		200	400	630	800	1000
功率消耗(W) Power Consumption	抽屉式 Draw-out type	40	101	123	110	171
	固定式 Fixed type	33	85	107	94	146

● 断路器在不同环境温度下额定持续电流变动见表13，即断路器降容系数（环境温度40℃）。

The rated continuous current of breaker at different ambient temperature as table 13, namely derating coefficient (under ambient temperature +40℃)

表13 Table 13

环境温度 Ambient air temperature		+40	+45	+50	+55	+60
允许持续工作电流 Permissible continuous operating current	1000A	1.0In	0.95In	0.92In	0.88In	0.85In

注：周围空气温度与允许持续工作电流关系(在各种环境温度条件下，实测断路器进出线端温度达到+110℃为基准。)

Note: the relation between ambient temperature and permissible continuous operating current (based on when the temperature reach up to +110℃ actually measured on incoming and outgoing terminals, at different ambient temperature)

● 断路器的附件功率消耗见表14。 Power consumption of accessories for breaker as table 14

表14 Table 14

类别 Type	额定电压 Rated voltage	AC220V	AC380V	DC220V	DC110V	备注 Remark
欠电压脱扣器 Undervoltage release		400VA		——		最大瞬时功耗 Maximum instantaneous power consumption
分励脱扣器 Shunt release		200VA		200W		
闭合电磁铁 Closing electromagnet		400VA		400W		
操作电动机 Operation counter		80VA		80W		——

外形及安装尺寸 Outline & installation size

● 固定式断路器的安装尺寸和外形尺寸见图2； Fixed type circuit breakers dimensions (see Figure 2)

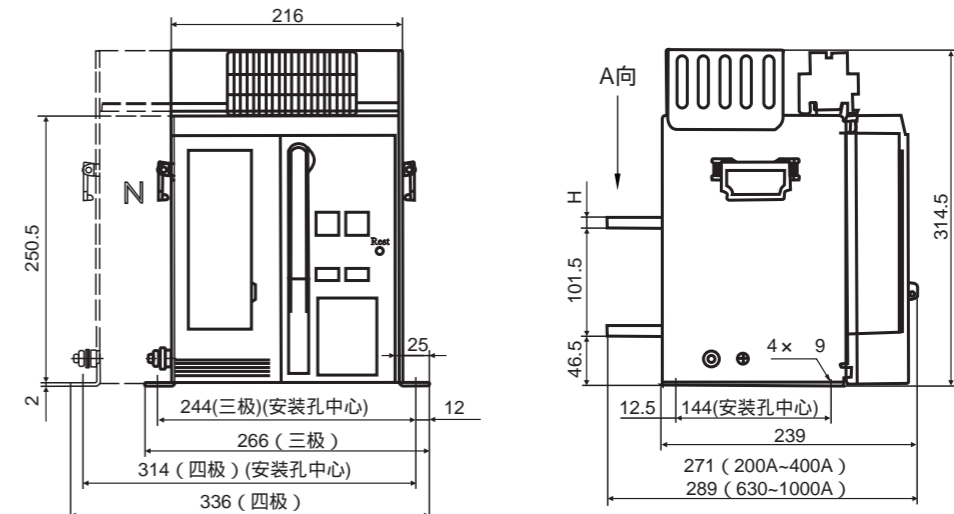

ZMW50-1000

智能型万能式断路器

Overload and short circuit instantaneous



图2 ZMW50-200A~1000A固定式断路器 Figure 2: Fixed type circuit breakers dimensions

额定电流 (A) Rated Current	200, 400	630	800, 1000	备注
母线厚度H (mm) Busbar thickness	6	8	10	—
n	6	12	12	三极
	8	16	16	四极

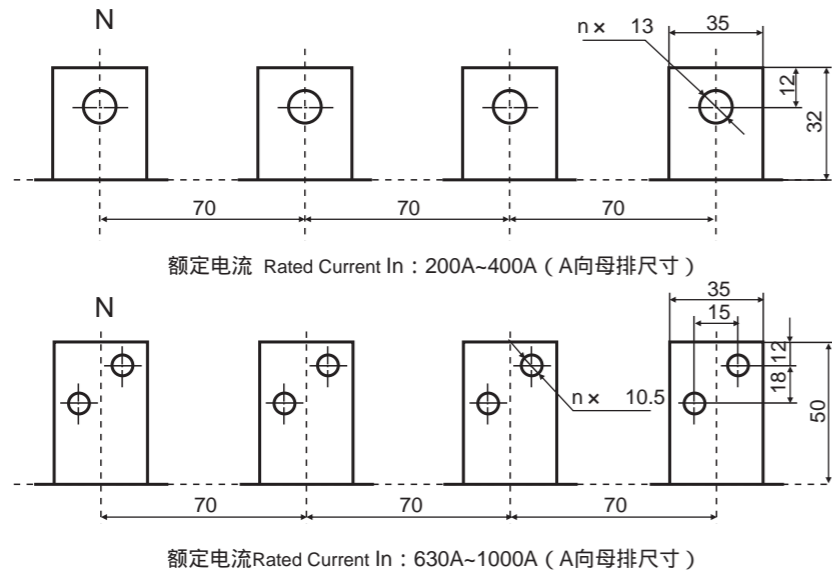

图3 ZMW50-200A~1000A抽屉式断路器 Figure 3: Draw-out type circuit breakers dimensions

额定电流 (A) Rated Current	200, 400	630	800, 1000	备注
母线厚度H (mm) Busbar thickness	6	8	10	—
n	6	12	12	三极
	8	16	16	四极

● 抽屉式断路器的安装尺寸和外形尺寸见图3。Draw-out type circuit breakers dimensions (see Figure 3)

● 抽屉式、固定式断路器的门柜开孔尺寸见图4 Door frame size & Mounting hole

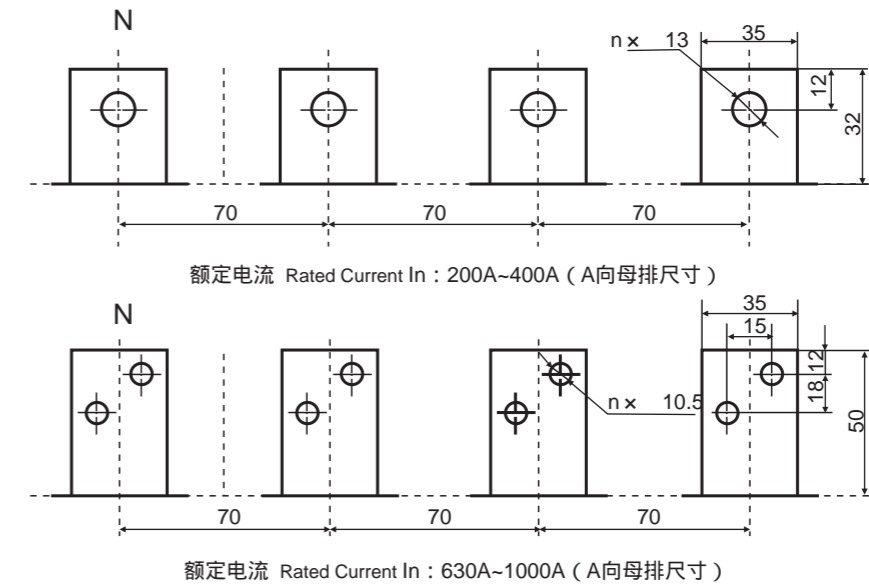
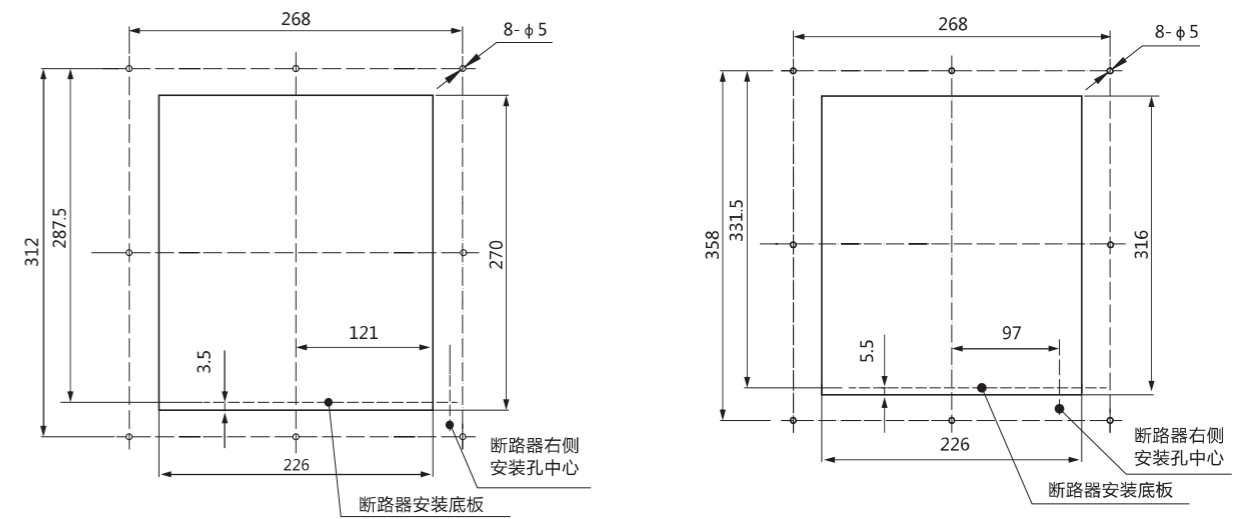
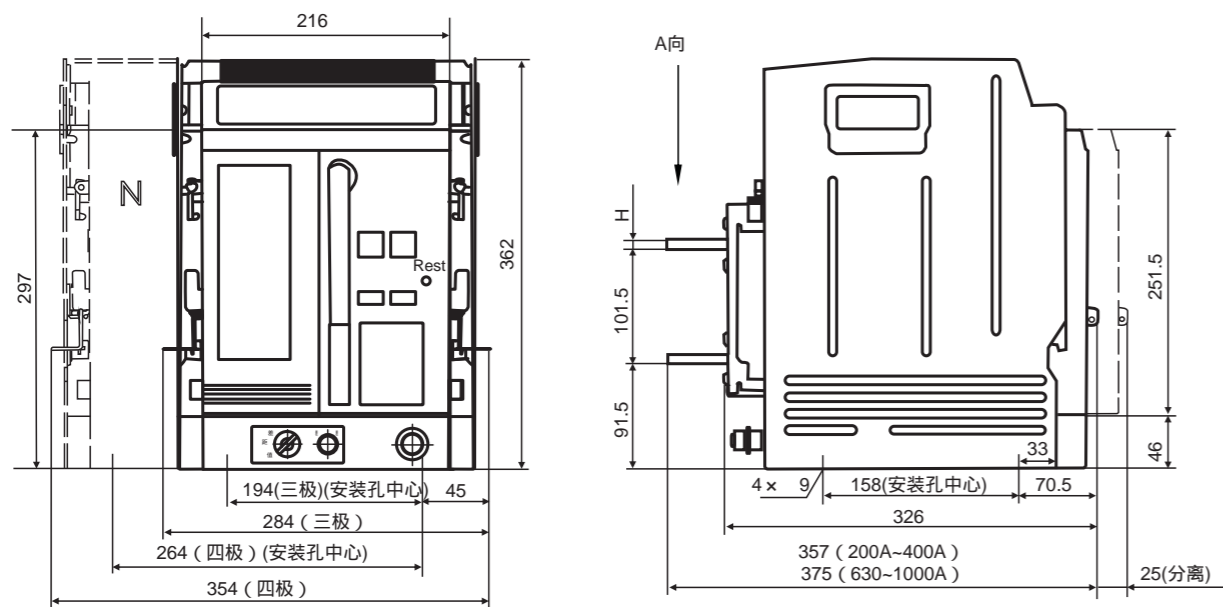

固定式3P/4P门框柜门开孔尺寸
Fixed type 3P/4P

图4 门柜开孔尺寸
Panel cutting size

抽屉式3P/4P门框柜门开孔尺寸
Draw-out type 3P/4P

ZMW50-1000

智能型万能式断路器

Overload and short circuit instantaneous

订货规范 Ordering sheet

(请在 内打 或填上数字，一个规格一张单)

用户单位 User	订货数量 (台) Order amount		订货日期 Order date			
型号 Type	ZMW50-1000	极数 Number of poles	3P 4P	安装方式 Installation mode	固定式 Fixed type 抽屉式 Draw-out type	
额定工作电压 Rated operating voltage	AC400V AC690V	额定电流 Rated Current $I_n =$ <input type="text"/> A				
智能型控制器 Intelligent Controller	类型 Type	H型 H-Type	M型 M-Type	L型 L-Type (L2, L3, L4)		
	基本功能 Basic function	过载长延时保护 Long delay overload protection	短路短延时保护 Short-circuit protection short delay	短路瞬时保护 Instantaneous short-circuit protection		
		接地或漏电保护 Neutral line grounding fault protection	故障记忆功能 Failure inquiry/memory function	试验功能 Test function		
	增选功能 Optional function	电流表功能 Measurement of current	热模拟功能 Electric energy measurement	通讯功能 Communication functions		
		负载监控功能 Load monitoring function	MCR功能 MCR make/break function	区域联锁功能 Regional interlock function	自诊断功能 Self-diagnosis function	
接地方式 Grounding	3PT	4PT	(3P-N)T(需外接互感器)			
控制器电源 Controller Power	AC400V	AC230V	DC220V(需增选电源模块 I)			
	DC110V(需增选电源模块 II)		DC240V(不需增选电源模块)			
标准附件 Accessories for optional configuration	分励脱扣器 Shunt release	AC400V	AC230V	DC220V	DC110V	
	合闸电磁铁 Closing electromagnet	AC400V	AC230V	DC220V	DC110V	
	电动操作机构 Operation counter	AC400V	AC230V	DC220V	DC110V	
	辅助开关 Auxiliary switch	标准型(3a3b)	特殊型(5a5b)	特殊型(6a6b)		
		Standard type(3a3b)	Special type(5a5b)	Special type(6a6b)		
欠电压脱扣器 Undervoltage release	AC400V	欠电压瞬时脱扣器 Instantaneous undervoltage release				
	AC230V	欠电压瞬时脱扣器 Instantaneous undervoltage release		1s	3s 5s	
断开位置锁定 OFF locking device	一锁一钥匙 1 lock 1 key		二锁一钥匙 2 lock 1 key	三锁二钥匙 3 lock 2 key		
机械联锁 Mechanical inter lock	钢缆绳联锁(二台) Steel cable interlock (2 breakers)		杠杆联锁二台开关 Interlock lever (2 breakers)	杠杆联锁三台开关 Interlock lever (3 breakers)		
其他附件 Other accessories	门联锁 Door interlock	抽屉座三位置锁 3-position locking device for the draw-out socket		抽屉座三位置信号输出 3-position signal output for the draw-out socket		
	扩展排 Extended busbar	相间隔板 Separator between phases		其他 Other		
连接 Connection mode	水平接线 Horizontal connection		垂直接线 Vertical connection	特殊接线 Special connection		

注：1、L型控制器为经济型，M型为普通型，H型在M型基础上增加通讯及位置锁功能(参照控制器类型)；
2、控制器的MCR功能为标准配置，针对M、H型产品增选漏电功能时，则无接地保护功能；
3、用户选用增选功能或带“ ”时，需另行增加费用。

Note: 1. L type controller is economic type, M type is common type, H type has extra communication and OFF position locking on basis of M type (please refer to controller types)
2. MCR function is the standard arrangement for controller, for M, H type if leakage function added, then earthing protection is not available.
3. If user select those optional functions or the one marked with " ", you shall pay additionally

备注：如用户订货还有其他特殊要求，请与厂家协商。 Note: If user has other special requirements, please discuss with factory.

ZMW2-1600

智能型万能式断路器

Overload and short circuit instantaneous



适用范围 Application

ZMW2-1600智能型低压万能式断路器(以下简称断路器),适用于交流50Hz, 额定工作电压至690V, 额定电流200A~1600A的配电网中, 用来分配电能和保护线路及电源设备免受过载、欠电压、短路、单相接地(漏电)等故障的危害。断路器具有智能化保护功能, 选择性保护精确, 能提高供电可靠性, 避免不必要的停电。同时带有开放式通讯接口, 便于与现场总线连接, 可实现“四遥”功能, 以满足控制中心和自动化系统的要求。配置相应的漏电互感器及智能控制器即可实现漏电保护。

断路器具有隔离功能, 采用符号“”表示。额定工作电流630A及以下的断路器, 亦可用于交流50(60)Hz、400V配电网中作为电动机的过载、短路、缺相、欠电压和接地等故障保护。在正常条件下, 断路器亦可作为线路的不频繁转换及电动机的不频繁启动之用。

断路器符合GB14048.1-2006《低压开关设备和控制设备：总则》；及GB14048.2-2008《低压开关设备和控制设备 第2部分：断路器》；GB14048.4-2003《低压开关设备及控制设备 机电式接触器和电动机起动器》等标准。

ZMW2-1600 conventional circuit breaker (hereinafter call “breaker”) is suitably used in the distribution circuit of AC 50Hz, rated voltage 690V, rated current 200 ~1600A, to distribute electric power and protect circuit and equipment from overloading, short circuit, under-voltage, single phase earthing, residual current faults. The breaker provides the intelligent protection function and high precise selective protection, improve the reliability of power supply, and prevent unnecessarily cutting off power supply. Meanwhile the breaker has opening communication port, convenient to connect with local bus, and realize four remote operations, to meet with the requirement of control center and automation. If leakage CT and intelligent controller assembled, the breaker can perform leakage protection.

The breaker has isolation function, use the symbol“” to indicate. The circuit breaker with rated current 630A and below can also be used to protect the motor from overload, short circuit, phase absence, under-voltage, and earthing fault. At normal conditions, the breaker can be used to transfer the lines or start the motor non-frequently.

The breaker complies with the standards of GB14048.1-2006 “Low-voltage switchgear and controlgear: General requirements”, GB14048.2-2008 “Low-voltage switchgear and controlgear Part 2: Low-voltage circuit breakers” and GB14048.4-2003 “Low-voltage switchgear and controlgear: Electromechanical contactors and motor starter”

型号及含义 Type and meaning

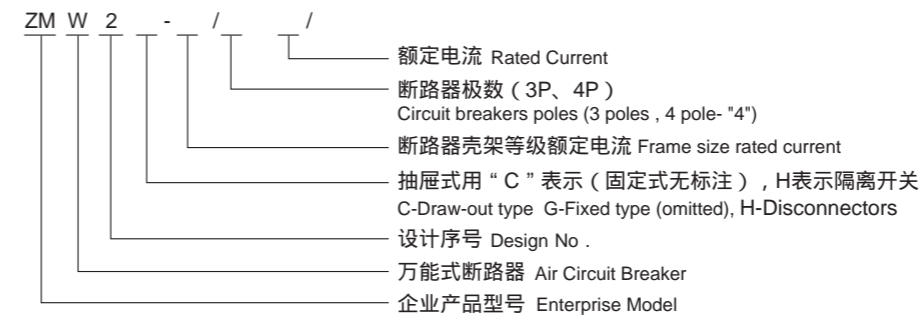

分类 Classification

- 按使用类别分：
- 主电路：A类（非选择性）、B类（选择性）及AC-3(直接操作电动机)
 - 辅助电路：AC-15、DC-13
 - 安装方式：固定式 抽屉式
 - 传动方式：电动机传动 手动
 - 极数：三极 四极
 - 按是否适合隔离分：适合隔离、不适合隔离
 - 按是否需要维修分：需要维修、不需要维修
 - 脱扣器种类：智能型控制器 分励脱扣器、欠电压瞬时(或延时)脱扣器
 - 智能型控制器分类
 - 2L型：经济型（基本功能）；
 - 3M型：基本型（基本功能+智能功能）；
 - 3H型：高级型（基本功能+智能功能+通讯接口）；

Classification according to usage category：

- Main circuit: Kind A (non selective type), Kind B (selective type) and AC-3 type (directly control motor)
- Auxiliary circuit: AC-15、DC-13
- According to mounting mode: Fixed type Draw-out type
- According to operating mode: Motor operation Hand Operation
- According to pole number: 3 poles 4 poles
- Classified depending on if isolation is available or not: feasible, unfeasible
- According to maintenance is required or not: required, not required
- Release types: intelligent controller, shunt release, under-voltage (instantaneous or delay) release
- Classification of intelligent controller
- 2L type: economic type (basic functions)
- 3M type: common type (basic functions +intelligent functions)
- 3H type: super type (basic function + intelligent functions + communication port)

ZMW2-1600

智能型万能式断路器

Overload and short circuit instantaneous



正常工作条件 Normal working condition

- 周围空气温度上限值不超过+40℃；下限值不低于-5℃；且24h平均值不超过+35℃；
- 注：对于使用在周围空气高于+40℃或低于-5℃的工作条件，用户应与制造厂协商。
- 安装地点海拔不超过2000m。
- 最高温度为+40℃时，空气的相对湿度不超过50%，在较低温度下可以有较高的相对湿度，例如20℃时达90%，对由于温度变化偶尔产生的凝露应采取特殊的措施。
- 污染等级3级
- 断路器安装在柜体内，且加装门框，防护等级达IP40。
- 断路器的主电路及欠电压脱扣器线圈，电源变压器初级线圈安装类别，其余辅助电路、控制电路安装类别为Ⅱ。
- 使用类别B类。
- 断路器的运输和储存条件：-25℃至+55℃，短时间内（24h内）可达+70℃。
- 断路器应安装在无爆炸危险和导电尘埃、无足以腐蚀金属和破坏绝缘的地方，且断路器的垂直倾斜度不超过5°。

- When the ambient air temperature is -5℃ to +40℃, the mean value is no greater than +35℃ with in 24 hours.
- Note: if the upper limit is higher than +40℃ or lower limit lower than -5℃ in work, discussions shall be made between the user and the manufacturer.
- Altitude: not higher than 2000m for the installation site.
- When the ambient air temperature is +40℃, the relative humidity of the air shall not be higher than 50%; a higher relative humidity is allowed at a lower temperature; special measures shall be taken for the condensation occasionally produced due to temperature change.
- Degree of Pollution: III
- Degree of protection: IP40
- The installation category of the breaker main circuit is IV; The installation category of the control circuit and auxiliary circuit is III, apart from the similarity between the under voltage release coil and the intellectual controller's power transformer primary coil and the breaker;
- Use Category B type
- Transportation and storage conditions of the circuit breaker: -25℃ to +55℃, short time (24h inside) up to +70℃
- The ambient air is not significantly polluted by dust, smoke, corrosive and/or flammable gases, vapours or salt. The mounting inclined angel shall not more the +5°

主要技术参数 Main Technical data

- 断路器的额定电流见表1 Circuit breakers rated current in Table 1 表1 Table 1

壳架等级额定电流Inm A Frame size rated current	额定电流In A Rated Current
1600	200, 400, 630, 800, 1000, 1250, 1600

- 断路器的额定绝缘电压690V；额定工作电压400V、690V。Circuit breakers rated insulation voltage 690V; rated working voltage of 400V, 690V.
- 断路器的额定短路接通能力应不小于2.1Icu。Rated short circuit making capacity of breaker shall not be less than 2.1Icu.
- 断路器的额定短路分断能力及短时耐受电流见表2。Rated short circuit breaking capacity and short time withstand current of the breaker as table 2 表2 Table 2

壳架等级额定电流Inm(A) Frame size rated current	1600	飞弧距离	进线方式
额定极限短路分断能力Icu(kA)0-C0 Rated ultimate short-circuit breaking capacity	AC400V 55 AC690V 25	零飞弧	上进线或下进线
额定运行短路分断能力Ics(kA)0-C0-C0 Rated short-circuit breaking capacity	AC400V 42 AC690V 20		
额定短时耐受电流Icw(kA) 1s 0-C0 Rated short time withstand current	AC400V 42 AC690V 20		

智能控制器保护特性 Protection characteristic of the Intelligent controller

- 1) 过电流脱扣器保护特性曲线见图1，接地故障保护特性曲线见图2。
Over current protection characteristics (Fig.1), Neutral line (grounding) fault protection characteristics (Fig.2)
- 2) 智能控制器的整定值及误差见表3。Controller Current setting & Accuracy (see table 3) 表3 Table 3

过电流脱扣器特性 Over current protection characteristics	整定值范围 Setting range		出厂整定值 Default setting
	2L	3M/3H	
长延时 IR Long delay	(0.4, 0.5, 0.6, 0.7, 0.8, 0.9, 1)In+OFF	(0.4~1)In+OFF	1In, 120s
短延时 Isd Short delay	L3:(3, 4, 6, 8, 10, 12, 15)In+OFF L4:(3, 4, 5, 6, 7, 8, 10)In+OFF	(1.5~15)In+OFF	6In, 0.2s
瞬时 li Instantaneous	L2:(3, 4, 6, 8, 10, 12, 15)In+OFF L3:(10, 11, 12, 14, 16, 18, 20)In+OFF	1In~50kA+OFF	10In
接地故障 Ig Grounding Fault	(0.2, 0.3, 0.4, 0.5, 0.6, 0.7, 0.8)In+OFF	(0.2~1)In+OFF	0.4In, 0.2s

- 注：1、OFF为过电流脱扣器保护特性处于关闭状态。
2、除非客户另有规定，产品出厂时按出厂整定值设定，客户需整定时请参照智能控制器使用说明书。
Note: 1. OFF means the protective characteristics of over-current release is closed.
2. Except for what the customer specify, the product will be set as defaults, if the user need adjustment, please refer to the operation manual of this breaker.

3) 智能控制器长延时过电流保护反时限动作特性

智能控制器长延时过电流保护反时限动作特性为 $tR = 1 / (5IR)^2 tR$ (式中tR:长延时1.5IR时整定时间, IR:长延时整定电流, TR长延时动作时间), 动作时间见表4, 可返回系数不小于0.9, 返回电流为0.9IR。

3) Long delay over-current inverse time limit tripping characteristics of intelligent controller

Inverse time tripping characteristics of overloading long delay tripping time: $tR = 1 / (1.5IR)^2 tR$ (tR: setting time of long time delay tripping at 1.5IR, IR: setting current of load time delay tripping, TR is long delay tripping time). Tripping time as table 4, returnable coefficient not less than 0.9, returned current is 0.9IR.

表4 Table 4

电流整定值 Current setting	动作时间 Action time										准确度 Accuracy
	2L					3M/3H					
1.05IR	> 2h不动作 No action					> 2h不动作 No action					± 15%
1.3IR	1h动作 Action										
1.5IR	30s	60s	120s	240s	15s	30s	60s	120s	240s	480s	
2.0IR	16.9s	33.7s	67.5s	135s	8.4s	16.9s	33.7s	67.5s	135s	270s	
7.2IR	1.3s	2.6s	5.2s	10.4s	0.65s	1.3s	2.6s	5.2s	10.4s	21s	
脱扣级别 Tripping level	—		10A	10	20	—		10A	10	20	

注：以上为配电和电动机保护整定时间，发电机保护用整定时间由用户与公司协商。

Note: the above-mentioned setting times are for distribution type breaker, if breaker used to protect motor, the setting time is negotiated between user and our company.

4) 智能控制器短路短延时动作特性

短路短延时过电流保护一般为定时限。如要求低倍数为反时限，其特性按 $Ts = (8IR)^2 tsd$ (或中Ts为短延时整定时间, tsd为短延时动作时间, 当过载电流 > 8IR时, 自动转换为定时限特性, 其动作特性见表5。

5) 智能控制器短路瞬时动作特性

短路瞬时的动作时间(含断路器固有分断时间)应小于30ms。其动作特性为: 0.85li时不动作, > 1.15li时动作。

4) Short delay tripping characteristics of intelligent controller

Generally it will be the definite time limit tripping. If inverse time limit trip at low times of rated current is required, its characteristics shall follow $I^2Ts = (8IR)^2 tsd$ (Ts is setting time for short time delay tripping, tsd is the short delay tripping time, when overloading current > 8IR, the controller will auto transfer to definite time limit tripping characteristics, as table 5.

5) Instantaneous tripping of short circuit for intelligent controller

Tripping time of short circuit instantaneous protection (including the opening time of the breaker) shall be less than 30ms. Its tripping characteristics: not trip at 0.85li; trip at > 1.15li



图1 过电流脱扣器保护特性曲线
Figure 1 Over current protection characteristics



图2 接地故障保护特性曲线 Figure 2 Neutral line (grounding) fault protection characteristics

表5 Table 5

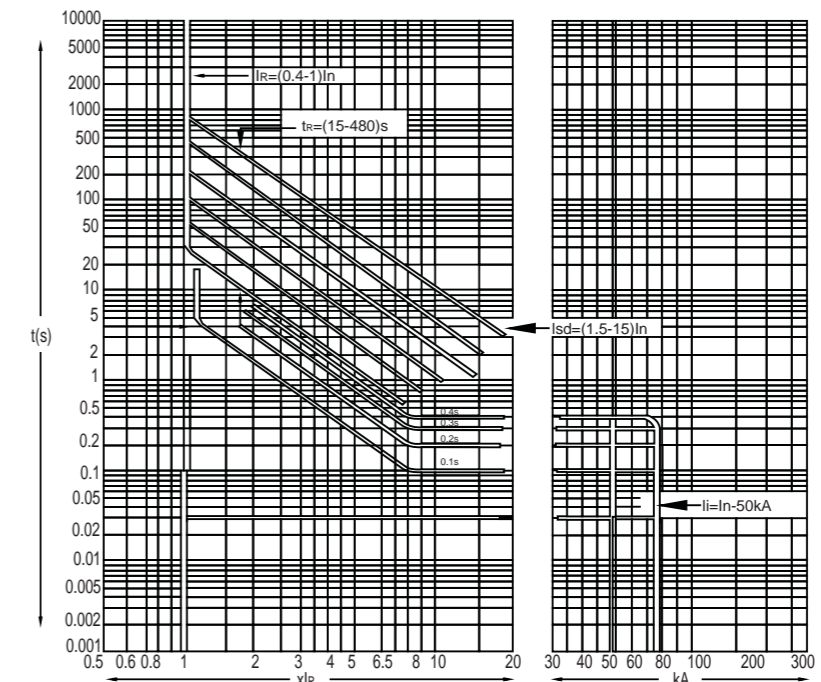
保护方式 Protection		动作时间 Action time				准确度 Accuracy
		2L		3M/3H		
定时限 Time limit	脱扣时间整定值 tsd Tripping time setting	200ms	400ms	0.1s~1s(0.1s极差)		± 10%
	最大分断时间 Maximum breaking time	230ms	460ms			
	不脱扣持续时间 Not trip duration	140ms	330ms			
反时限特性 Inverse time characteristics		无				曲线同过载延时,但曲线速度快10倍
动作特性 Operating Characteristics		0.9Isd 不动作 No action				
		> 1.1Isd 延时动作 Delay action				

6) 接地故障保护动作特性为定时限，其延时特性符合表6。 Earth fault protection is the definite time tripping, the time delay as table 6.

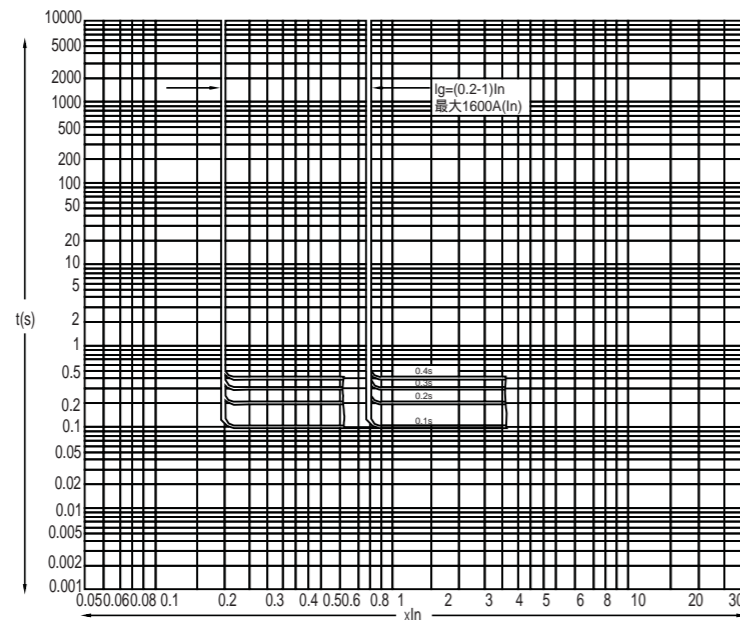
表6 Table 6

保护方式 Protection		动作时间				准确度
		2L		3M/3H		
定时限 Time limit	脱扣时间整定值 tg Tripping time setting	200ms	400ms	600ms	800ms	± 10%
	最大分断时间 Maximum breaking time	230ms	460ms	650ms	850ms	
	可返回时间 Not trip duration	140ms	330ms	560ms	760ms	
动作特性 Operating Characteristics		0.8Ig 不动作 No action				
		< 1.0Ig 延时动作 Delay action				

7) 剩余漏电流保护是通过外接外部漏电互感器来实现剩余漏电流讯号检测，动作特性为延时型。其延时特性符合表(表中不包括控制器固有动作时间20ms)

额定剩余动作电流 I_n : 3A、10A、20A、30A。

额定剩余不动作电流 (I_{no}) 的最小值为 $0.5I_n$ 。

The residual current protection is performed via an exterior electric leakage current transformer to monitor electric leakage, the tripping characteristics is time delay type, as table 7 (the inherent time delay 20ms of controller is not included),

Rated residual tripping current I_n : 3A, 10A, 20A, 30A

The minimum of rated residual tripping current I_{no} : $0.5I_n$

表7 Table 7

极限不驱动时间(2I _n 时) Do not drive time limit	0.06s	0.1s	0.2s	0.3s	0.4s	0.5s	1s
剩余电流 Residual current	最大断开时间 (s) Maximum break time						
I_n	0.36	0.50	1.00	1.50	2.00	2.50	5.00
$2I_n$	0.18	0.25	0.50	0.75	1.00	1.25	2.50
$5I_n$ 、 $5I_{n'}$	0.07	0.10	0.20	0.30	0.40	0.50	1.00

8) 接地或剩余电流保护方式

接地或剩余电流保护是由于设备对大地有泄漏电流，作为保护设备的一种保护功能。根据泄漏电流的大小分为接地保护和剩余电流保护。

接地保护是控制器根据三相电流和中性电流矢量和进行保护。根据断路器极数分3PT、4PT、(3P+N)T三种保护方式(见图)。

剩余电流保护是控制器直接取外加电流互感器的输出电流信号进行保护，保护灵敏度高，特别适用于几安培到几十安培的较小接地电流的保护。接地信号取样有两种方式，一种为矩形互感器(ZCT1)取样，另一种为直径100mm的环形互感器(ZT100)取样。

8) Earthing or residual current protection modes

Earthing or residual current protection is used to break leakage current from equipment to ground, as one of protection function, according to the value of leakage current, it divided into earthing protection and residual current protection.

Earthing protection will be performed according to the vector sum of three-phase and neutral current determined by the controller. According to pole number of circuit breaker, it can divided into: 3PT、4PT、(3P+N)T three kinds of protection modes (Picture 3)

Residual current protection will be executed according to output current signal of exterior CT directly read by controller, high sensitivity, especially suitable for protection of several to tens amperes, earthing current sampling has two modes: one is through rectangular CT (ZCT1), another is through ring CT (ZT100) (dia. 100mm)

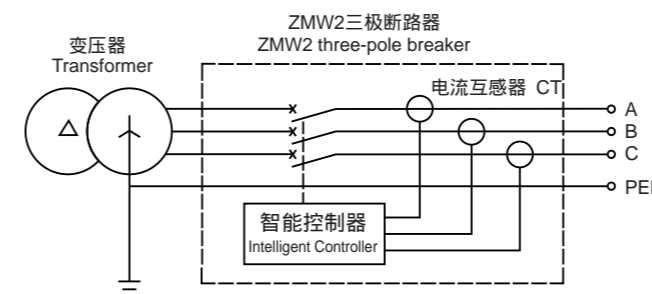

3PT型

差值型接地故障保护，信号只取三相电流的矢量和(三相不平衡)

3PT type

Difference type earthing fault protection, the signal just sampled from the vector sum of three-phase current (three-phase imbalanced current)

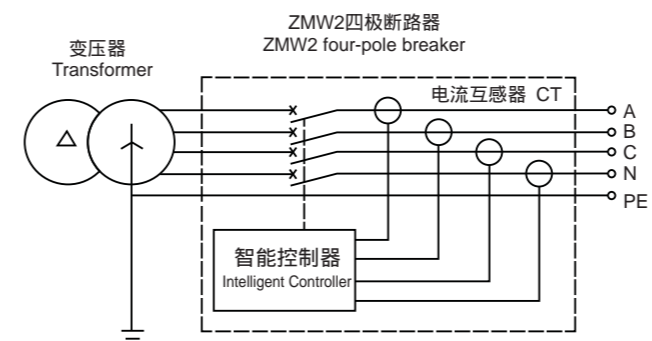

4PT型

差值型接地故障保护，信号取三相电流及N相电流的矢量和

4PT type

Difference type earthing fault protection, the signal sampled from the vector sum of three-phase current and Neutral line current

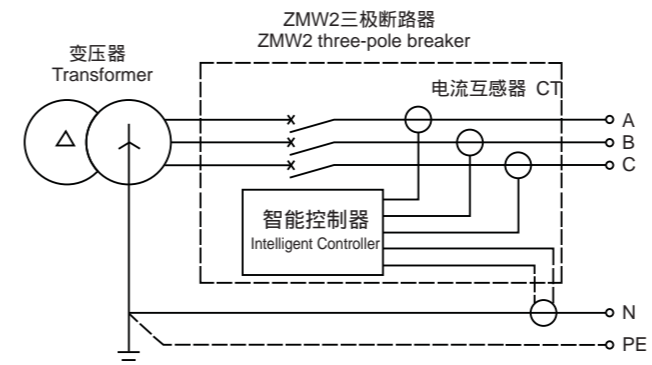

(3P+N)T型外接中性极互感器

差值型接地故障保护，信号取三相电流及N相电流的矢量和

(3P+N)T type connected to outer Neutral line current transformer

Difference type earthing fault protection, the signal sampled from the vector sum of three-phase current and Neutral line current

图3 接地保护方式 Figure 3 Ground Protection

ZMW2-1600

智能型万能式断路器

Overload and short circuit instantaneous



● 断路器的操作性能见表8。 Operation performances of breaker are shown by operation cycles(see table 8)

表8 Table 8

壳架等级额定电流 Inm(A) Rated frame size current	每小时操作循环次数 Operating cycles per hour	操作循环次数 Operating cycles		
		通电 Energize	不通电 Not energized	总数 Total
1600	20	500	3000	2500

注：1. 每小时实际操作循环次数应记录在试验报告中； Note: 1. Actual operating cycles per an hour shall be record in test report;
2. 每个通电操作循环期间，保持接通的最长时间为2s。 2. Maxi duration of remaining being electrified is 2s during each operating cycle.
3. 电操机构操作循环次数及手动操作循环次数为总数的1/2。 3. Operation cycles by motor and hand are 1/2 of total operation cycles.

● 断路器的分励脱扣器、欠电压脱扣器、电动操作机构、释能（合闸）电磁铁、智能控制的工作电压及所需功耗见表9。
Operating voltage and power consumption of shunt release, under-voltage release, motor operating mechanism, releasing (closing) electromagnet, and intelligent controller see as table 9.

表9 Table 9

项 Description	AC50Hz		DC	
	220V	380V	110V	220V
分励脱扣器 Shunt release	24VA	36VA	24W	24W
欠电压脱扣器 Undervoltage release	24VA	36VA	-	-
合闸电磁铁 Closing electromagnet	24VA	36VA	24W	24W
电动操作机构 Operation counter	85VA	85VA	85W	85W
智能控制器电源电压 Power voltage of controller	AC220V、AC380V、DC220V、DC110V、DC24V			

注：1. 控制器工作电压为DC24V，其变压器或电源模块一次侧可提供电压为AC380V、220V（50Hz）或DC220V、110V。
2. 分励脱扣器的可靠动作电压范围为70%~110%，合闸电磁铁和操作机构为85%~110%。
Note: 1. Operating voltage of controller is DC24V, input side of the transformer or power source module can be AC380V、220V（50Hz） or DC220V、110V
2. Reliable operating voltage range for shunt release is 70%~110%， for closing electromagnet and operating mechanism is 85%~110%.

● 8) 断路器的欠电压脱扣器性能见表10 The characteristics of under-voltage release as table 10

表10 Table 10

类别 pe	欠电压延时脱扣器 Undervoltage time delay release		欠电压瞬时脱扣器 Undervoltage instantaneous release	
	脱扣器动作时间 Action time release	延时 time delay 1、3、5s	瞬时 Instantaneous	
脱扣器动作电压值 Release operation voltage value	35%~70%Ue	断路器可靠断开 Reliable disconnect breaker		
	35%Ue	断路器不能闭合 Breaker can not be closed		
	(85~110%) Ue	断路器能可靠闭合 Breaker can be reliably closed		
在1/2延时时间内，如果电源电压恢复到85%Ue时 Within 1/2 time delay, if power source recover up to 85% Ue		断路器不断开 Breaker can not OFF		

注：延时时间精度为±10% Note: Time delay Accuracy ±10%

● 辅助触头的性能 Auxiliary contacts

1) 辅助触头的约定发热电流为6A，额定工作电压对交流为127V、220V、380V，对直流为110V、220V，控制容量为300VA/Ue（交流）及30W/Ue（直流）；
2) 辅助触头形式：四常开四常闭，特殊形式订货时应说明。
3) 辅助触头的非正常接通与分断能力

1) Conventional thermal current of auxiliary contact Ith = 6A, AC rated voltage 127V, 220V, 400V 230V, or DC220V, 110V, the rated control capacity: 300VA/Ue (AC), or 30W/Ue(DC)
2) The types of auxiliary contacts: 4 NO + 4NC, other than this, please indicate it when to book the product.
3) The abnormal making and breaking capacity of auxiliary contacts

辅助触头非正常使用条件下的接通分断能力见表11。 The abnormal making and breaking capacity of auxiliary contacts as table 11

表11 Table 11

使用类别 Use Category	接通 Making			分断 Breaking			通断操作循环次数和操作频率 Operating cycles and operating frequency		
	I/le	U/Ue	COS 或 T0.95	I/le	U/Ue	COS 或 T0.95	操作循环次数 Operating cycles	每分钟操作循环次数 Operating cycles per minute	通电时间 (s) Power-on time
AC-15	10	1.1	0.3	10	1.1	0.3	10	6(与主回路操作频率相同) Operating frequency with the main circuit	0.5
DC-13	1.1	1.14	300ms	1.1	1.14	300ms			

4) 辅助触头正常条件下的接通与分断能力见表12 The normal making and breaking capacity of auxiliary contacts as table 12

表12 Table 12

使用类别 Use Category	接通 Making			分断 Breaking		
	I/le	U/Ue	COS 或T0.95	I/le	U/Ue	COS 或T0.95
AC-15	10	1	0.3	1	1	0.3
DC-13	1	1	300ms	1	1	300ms

● 温升试验用铜排（或PVC绝缘铜线）截面（见表13）

The sectional cross area of copper busbar (or PVC insulated cable) used for temperature rise test (As table 13)

表13 Table 13

试验电流 (A) Test current	铜导线 Copper wire		铜导线 Copper wire	
	根数 Quantity	截面mm ² Cross-sectional area	根数 Quantity	尺寸mm Dimension
200A	1	95		
400A	1	240		
630A	2	185	2	40 × 5
800A	2	240	2	50 × 5
1000A			2	60 × 5
1250A			2	80 × 5
1600A			2	100 × 5

表中规格为断路器处于周围环境温度最高+40，敞开安装且满足GB14048.2中约定发热条件下所采用的铜排规格。

● 断路器的最大耗损功率（环境温度+40）。

ZMW2-1600 三极 340W

ZMW2-1600 四极 400W

● 断路器的降容系数（见表14）

表14表示断路器在所处周围环境温度且满足GB14048.2中约定发热条件下持续承载电流的能力。

The data is busbar specification which can meet with the requirement of conventional thermal in GB14048.2 standard under highest ambient temperature +40

● Maxi power loss of breaker (ambient temperature +40)

ZMW2-1600 3P: 340W

ZMW2-1600 4P 400W

● Derating coefficient of breaker (as table 14)

Table 14 show the current carrying capacity in compliance with the requirement of GB14048.2 standard under the ambient temperature.

表14 Table 14

环境温度 Ambient air temperature	+40	+45	+50	+55	+60	
允许持续工作电流 Permissible continuous operating current	1600A	1.0In	0.95In	0.92In	0.88In	0.85In

● 断开位置钥匙锁（可选件）

断路器具有“断开位置钥匙锁”附件（按订货要求供货）。能将断路器锁定在断开位置。此无论用合闸按钮或释能（合闸）电磁铁均不能使断路器闭合。适用于远距离断路器之间联锁。

● 钢缆机械联锁或连杆式机械联锁（可选件）

可实现二台或三台断路器水平排列安装或垂直排列安装不同状态的联锁。

● 门连锁（可选件）

断路器在“连接”或“试验”位置，禁止柜门打开。柜门已打开，而断路器在“试验”位置，不用断开断路器就能够关闭柜门。

● Key for OFF position (optional)

The breaker can provide the accessory for locking in OFF position by padlock (please indicate when to book the product), it can lock the breaker in OFF position. At this case both ON pushbutton or releasing (CLOSE) electromagnet can't make breaker to be closed. This is suitable for the interlock between breakers located faraway.

● Mechanical interlock by steel rope or connecting rod (optional)

This function can realize the interlock between two or three pieces of breaker mounted in horizon or vertically.

● Door interlock (optional)

When breaker is in DISCONNECTED or TEST position, panel door not allowed to be opened.

When panel door is opened and breaker in TEST position, it can close the panel door without need of opening the breaker.

外形及安装尺寸 Outline & installation size

● ZMW2-200A~1600A固定式断路器外形及安装尺寸 ZMW2-200A~1600A Fixed type circuit breakers dimensions

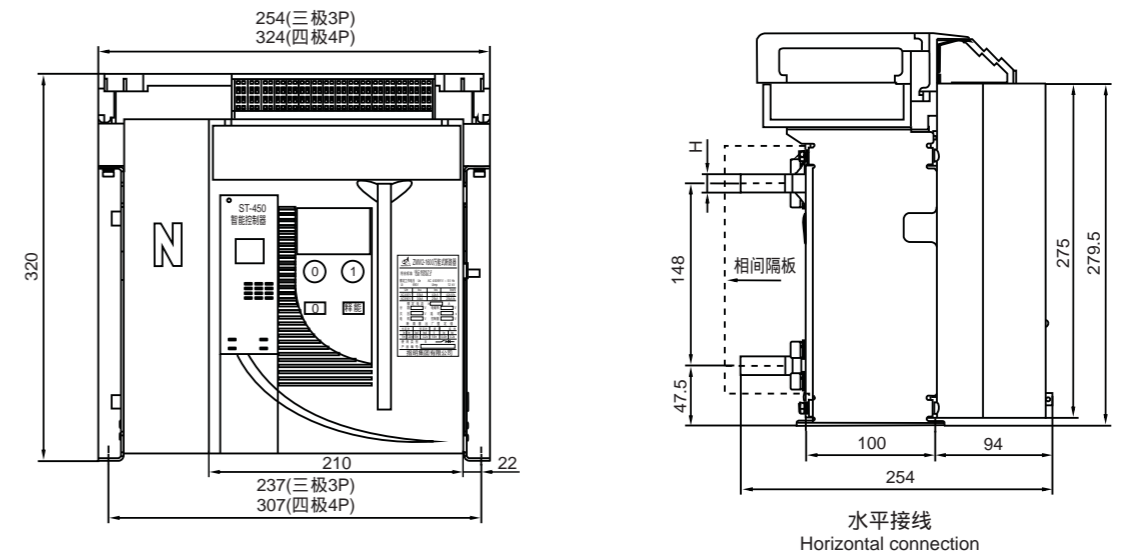



图4 ZMW2-200A~1600A固定式断路器
Figure 4: ZMW2-200A~1600A Fixed type circuit breakers dimensions



图5 ZMW2-200A~1600A抽展式断路器
Figure 5: ZMW2-200A~1600A Draw-out type circuit breakers dimensions

● ZMW2-200A~1600A抽展式断路器外形及安装尺寸 ZMW2-200A~1600A Draw-out type circuit breakers dimensions

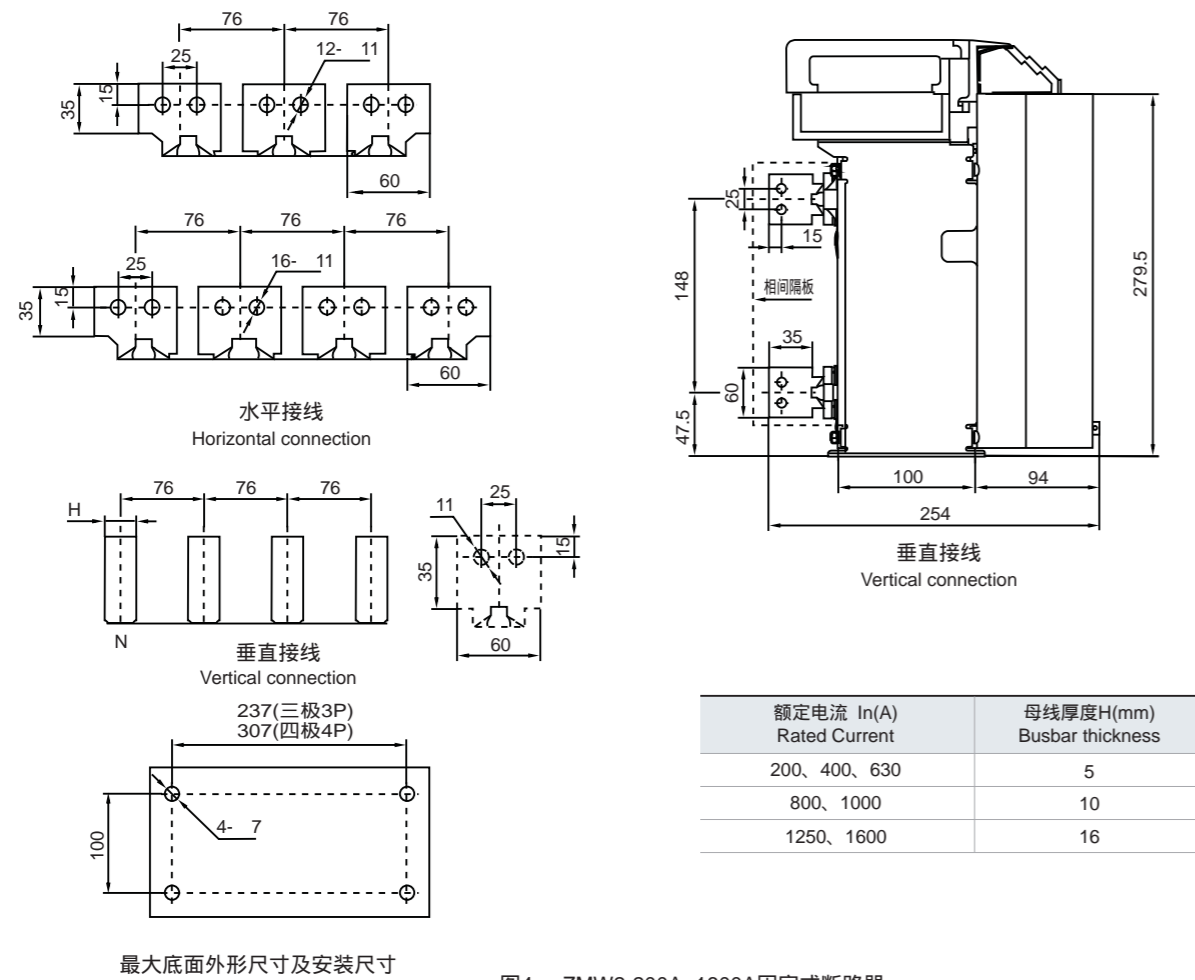

● 断路器门框开孔与安装尺寸 (见图6) Door frame size & Mounting hole (see Figure 6)

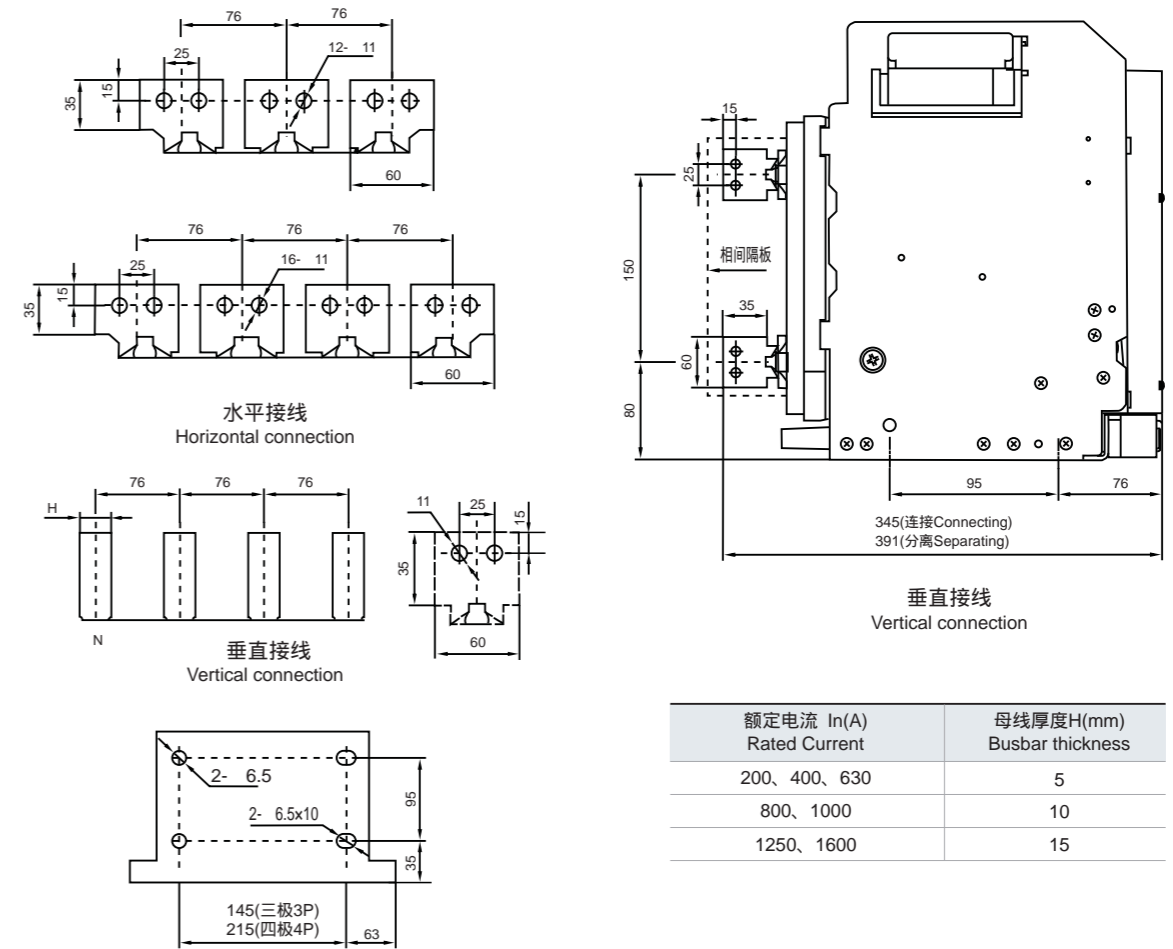
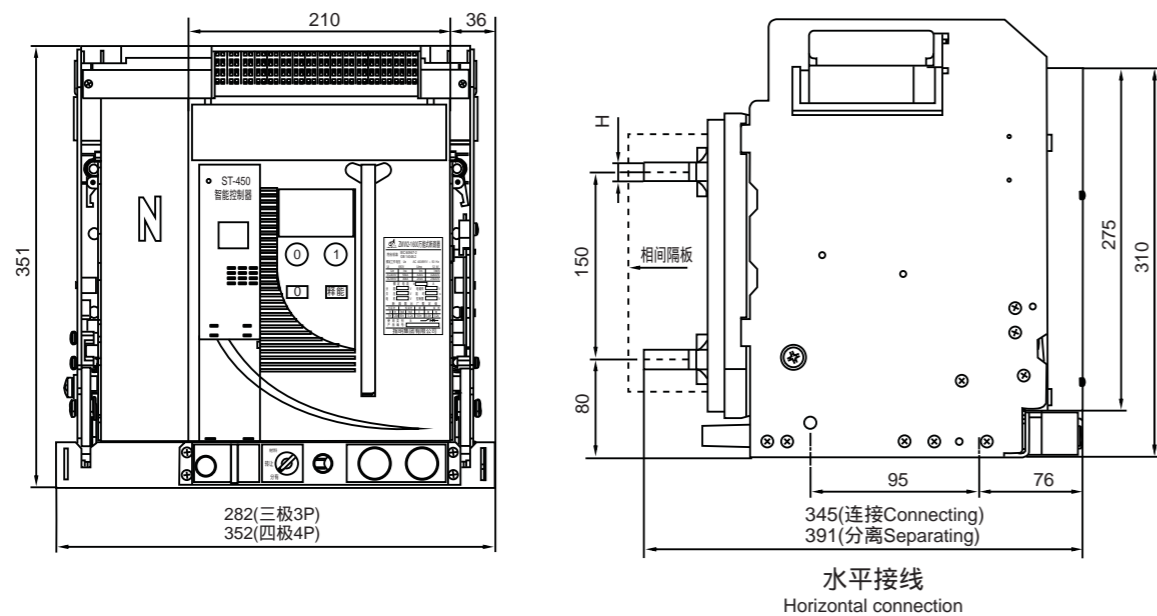

图6 ZMW2-1600/3P、4P断路器门框开孔与安装尺寸
Figure 6 ZMW2-1600/3P、4P Door frame size & Mounting hole

ZMW2-1600

智能型万能式断路器

Overload and short circuit instantaneous

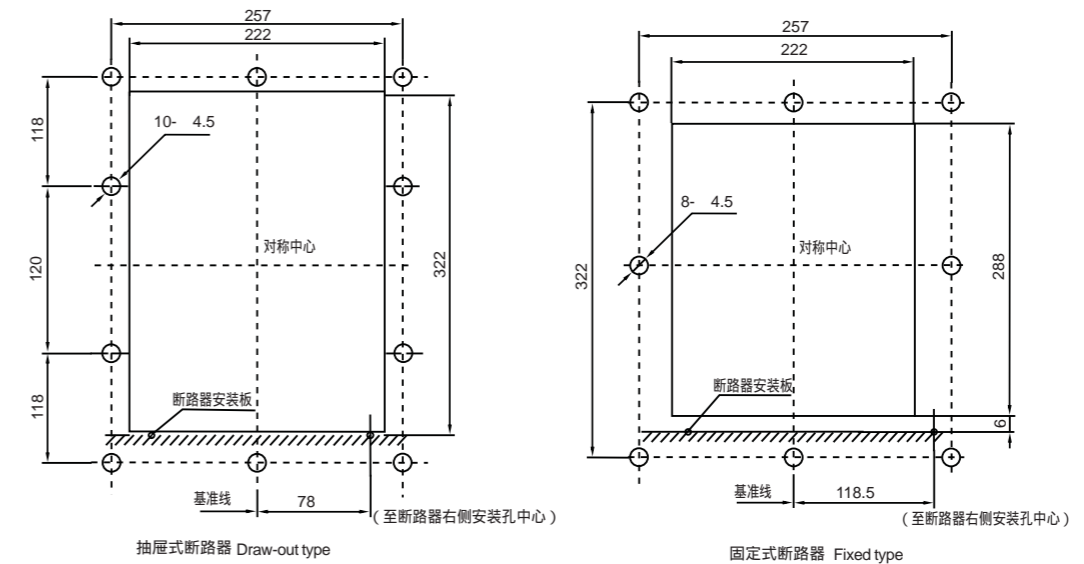
订货规范 Ordering sheet

(请在 内打 或填上数字，一个规格一张单)

用户单位 User	订货数量 (台) Order amount		订货日期 Order date		
型号 Type	ZMW2-1600	极数 Number of poles	3P 4P	安装方式 Installation mode	固定式 Fixed type 抽屉式 Draw-out type
额定工作电压 Rated operating voltage	AC400V AC690V	额定电流 Rated Current $I_n =$ <input type="text"/> A			
智能型控制器 Intelligent Controller	类型 Type	H型 H-Type	M型 M-Type	L型 L-Type (L2, L3, L4)	
	基本功能 Basic function	过载长延时保护 Long delay overload protection	短路短延时保护 Short-circuit protection short delay	短路瞬时保护 Instantaneous short-circuit protection	
	增选功能 Optional function	电流表功能 Measurement of current	热模拟功能 Electric energy measurement	通讯功能 Communication functions	
	接地方式 Grounding	3PT	4PT	(3P+N)T(需外接互感器)	
	控制器电源 Controller Power	AC400V	AC230V	DC220V(需增选电源模块 I)	
标准附件 Accessories for optional configuration	分励脱扣器 Shunt release	AC400V	AC230V	DC220V	DC110V
	合闸电磁铁 Closing electromagnet	AC400V	AC230V	DC220V	DC110V
	电动操作机构 Operation counter	AC400V	AC230V	DC220V	DC110V
	辅助开关 Auxiliary switch	标准型(3a3b) Standard type(3a3b)	特殊型(5a5b) Special type(5a5b)	特殊型(6a6b) Special type(6a6b)	
可增选附件 Accessories for standard configuration	欠电压脱扣器 Undervoltage release	AC400V	欠电压瞬时脱扣器 Instantaneous undervoltage release		
	断开位置锁定 OFF locking device	AC230V	欠电压瞬时脱扣器 Instantaneous undervoltage release		
	机械联锁 Mechanical inter lock	一锁一钥匙 1 lock 1 key	二锁一钥匙 2 lock 1 key	三锁二钥匙 3 lock 2 key	1s 3s 5s
	其他附件 Other accessories	门联锁 Door interlock	抽插座三位置锁 3-position locking device for the draw-out socket	抽插座三位置信号输出 3-position signal output for the draw-out socket	
连接 Connection mode	水平接线 Horizontal connection	垂直接线 Vertical connection	特殊接线 Special connection		

注：1、L型控制器为经济型，M型为普通型，H型在M型基础上增加通讯及位置锁功能(参照控制器类型)；
2、控制器的MCR功能为标准配置，针对M、H型产品增选漏电功能时，则无接地保护功能；
3、用户选用增选功能或带“ ”时，需另行增加费用。

Note: 1. L type controller is economic type, M type is common type, H type has extra communication and OFF position locking on basis of M type (please refer to controller types)
2. MCR function is the standard arrangement for controller, for M, H type if leakage function added, then earthing protection is not available.
3. If user select those optional functions or the one marked with " ", you shall pay additionally

备注：如用户订货还有其他特殊要求，请与厂家协商。 Note: If user has other special requirements, please discuss with factory.

JR36

系列热继电器

Series Thermal Relay



适用范围 Application

JR36系列热继电器适用于交流50Hz或60Hz，主电路额定电压660V，电流至160A的电力系统中作为三相交流电动机的过载和断相保护，具有温度补偿，自动与手动复位功能。

JR36series thermal relay is suitable for AC 50Hz or 60Hz, main circuit rated voltage up to 660V, current up to 160A, used as protecting AC three-phase motor against overload and has the functions of breaking phase protection, temperature compe. It can automatically and manually reset, too.

主要技术参数 Main technical data

1、动作特性：三相负载平衡时的动作时间
Motion characteristic: three-phase balance motion time

序号 No.	整定电流倍数 Set current cinles	动作时间 Motion time	起始条件 Start condition	环境温度 Temperature
1	1.05	> 2h	冷态 Cold state	20 ± 5
2	1.2	< 2h	热态heat state	
3	1.5	< 4min	(接序号1试验后Following the No.1test)	
4	7.2	10A 2s √Tp 10s 63A 10A 4s √Tp 10s > 63A	冷态 Cold state	

2、动作特性：三相负载平衡时的动作时间
Motion characteristic: three-phase balance motion time

序号 No.	整定电流倍数 Set current cinles	动作时间 Motion time	起始条件 Start condition	环境温度 Temperature
	任意二相 Arbitrary two phase	第三相 Three phase		
1	1.0	0.9	> 2h	冷态 Cold state
2	1.15	0	< 2h	热态heat state (接序号1试验后Following the No.1test)

3、规格 Specifications

型号 Type	JR36-20	JR36-32	JR36-63	JR36-160
额定电流范围(A) Setting range(A)	0.25~0.35	10~16	14~22	40~63
	0.32~0.5	14~22	20~32	53~85
	0.45~0.72	20~32	28~45	75~120
	0.68~1.1		40~63	100~160
	1~1.6			
	1.5~2.4			
	2.2~3.5			
	3.2~5			
	4.5~7.2			
	6.8~11			
10~16				
14~22				
安装尺寸 Installation dimension	38mm	66mm	66mm	90mm

型号及含义 Type and meaning

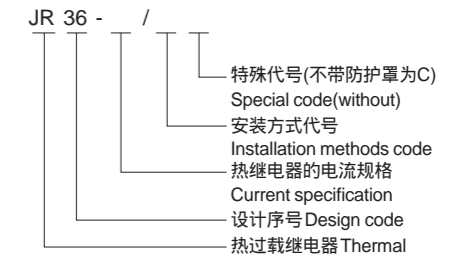

JRS1, JR28 系列热继电器 Series Thermal Relay



主要技术参数 Main technical data

1、动作特性：三相负载平衡时的动作时间
Motion characteristic: three-phase balance motion time

序号 No.	整定电流倍数 Set current cinles	动作时间 Motion time	起始条件 Start condition	环境温度 Temperature
1	1.05	> 2h	冷态 Cold state	20 ± 5
2	1.2	< 2h	热态 heat state	
3	1.5	< 4min	(接序号1试验后 Following the No.1 test)	
4	7.2	10A 2s < Tp 10s 63A 10A 4s < Tp 10s > 63A	冷态 Cold state	

2、动作特性：三相负载平衡时的动作时间
Motion characteristic: three-phase balance motion time

序号 No.	整定电流倍数 Set current cinles		动作时间 Motion time	起始条件 Start condition	环境温度 Temperature
	任意二相 Arbitrary two phase	第三相 Three phase			
1	1.0	0.9	> 2h	冷态 Cold state	20 ± 5
2	1.15	0	< 2h	热态 heat state (接序号1试验后 Following the No.1 test)	

3、规格 Specifications

型号 Type	编号 Number	整定电流范围(A) Setting Range(A)	可插接安装的接触器 Contactors insert	型号 Type	编号 Number	整定电流范围(A) Setting Range(A)	可插接安装的接触器 Contactors insert
JRS1 (LR1-D)	09301	0.1~0.16	D09-D25	JR28 (LR2-D)	1301	0.1~0.16	D09-D32
	09302	0.16~0.25	D09-D25		1302	0.16~0.25	D09-D32
	39303	0.25~0.4	D09-D25		1303	0.25~0.4	D09-D32
	09304	0.4~0.63	D09-D25		1304	0.4~0.63	D09-D32
	09305	0.63~1	D09-D25		1305	0.63~1	D09-D32
	09306	1~1.6	D09-D25		1306	1~1.6	D09-D32
	09307	1.6~2.5	D09-D25		1307	1.6~2.5	D09-D32
	09308	2.5~4	D09-D25		1308	2.5~4	D09-D32
	09310	4~6	D09-D25		1310	4~6	D09-D32
	09312	5.5~8	D09-D25		1312	5.5~8	D12-D32
	09314	7~10	D09-D25		1314	7~10	D18-D32
	12316	10~13	D09-D25		1316	9~13	D25-D32
	16321	13~18	D09-D25		1321	12~18	D25-D32
	25322	18~25	D09-D25		1322	17~25	D32
	40353	23~32	D09-D25		2353	23~32	D25-D32
	40355	30~40	D40,D50,D63		2355	30~40	D25-D32
	63357	38~50	D40,D50,D63		3322	17~25	D40-D95
63359	48~57	D40,D50,D63	3353	23~32	D40-D95		
63361	57~66	D40,D50,D63	3355	30~40	D40-D95		
80363	63~80	D40,D50,D63	3357	37~50	D50-D95		
			3359	18~65	D50-D95		
			3361	55~70	D65-D95		
			3363	63~80	D80-D95		
			3365	80~93	D95		

CJT1 系列交流接触器 Series AC Contactor

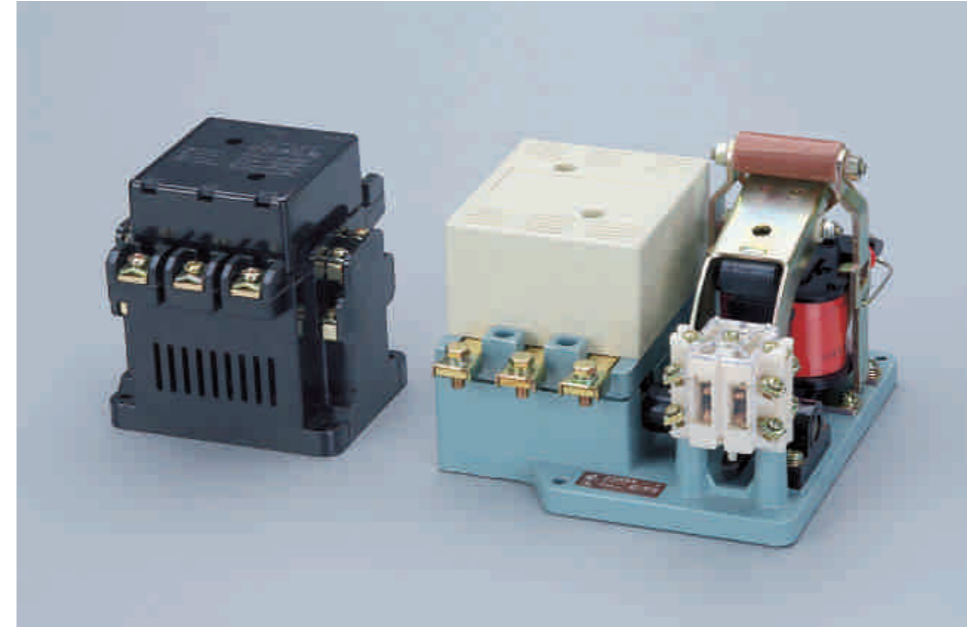

主要技术参数 Main technical data

- 接触器主电路的基本参数见下表。
Basic parameters of contactor main circuit are shown as the following list.
- 接触器的吸引圈在其额定控制电源电压Us的85%~110%范围内能正常工作。
The pull-in windings of contactor can work normally at 85%~110% of rated control supply voltage Us.

型号 Type	Ui V	Ue V	I _{th} A	断续周期工作制下的I _e (A) I _e under intermittent periodic duty				AC-3的P _e (kW)
				AC-1	AC-2	AC-3	AC-4	
CJT1-10	690	220	10	10	10	10	10	2.2
		380			5	5	5	4
		660			5	5	5	4
CJT1-20	690	220	20	20	20	20	20	5.5
		380			12	12	12	10
		660			12	12	12	10
CJT1-40	690	220	40	40	40	40	40	11
		380			25	25	25	20
		660			25	25	25	20
CJT1-60	690	220	60	60	60	60	60	17
		380			40	40	40	30
		660			40	40	40	35
CJT1-100	690	220	100	100	100	100	100	28
		380			60	60	60	50
		660			60	60	60	50
CJT1-150	690	220	150	150	150	150	150	43
		380			100	100	100	75
		660			100	100	100	75

适用范围 Application

CJT1系列交流接触器(以下简称接触器)主要用于交流50Hz、额定工作电压最高至660V, AC-3使用类别下, 380V时的额定工作电流至150A、660V时的额定工作电流至100A的电力系统中,供远距离接通和分断电路或频繁地起动和控制交流电动机的运转。可与适当的热过载继电器或电子式保护装置组成电磁起动器,以保护可能发生过载的电路。

产品符合GB 14048.4和IEC 60947-4-1等标准。

CJT1 series AC contactor (hereinafter referred to as contactor) is suitable for the power system of AC 50Hz and rated working voltage up to 660V, or the power system of rated working current up to 150A at 380V and rated working current up to 100A at 660V under AC - 3 utilization, to make and break circuit in a far distance, or to frequently start and control AC motor. The contactor can be combined with thermal overload relay or electronic protection equipment to form into an electromagnetic starter, to protect the circuit against possible overload. The products are in conformity with such standards as GB 14048.4 and IEC 60947-4-1.

外形及安装尺寸 Outline & installation size

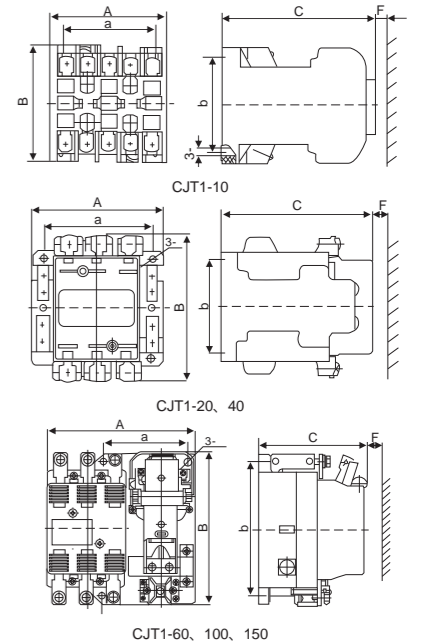

型号 Type	A	a	B	b	C	F
CJT1-10	70	56	70	58	95	4.5 > 15
CJT1-20	94	76	104	68	110	5 > 15
CJT1-40	116	100	131	75	126	5.5 > 15
CJT1-60	171	98	182	160	137	7 > 35
CJT1-100	198	110	206	180	143	9 > 45
CJT1-150	222	130	234	205	154	11 > 55

CJ20 系列交流接触器 Series AC Contactor



主要技术参数 Main technical data

接触器主电路的基本参数见下表。
Basic parameters of contactor main circuit are shown as the following list.

型号 Type	Ui V	Ue V	Ith A	断续周期工作剩下的Ie(A) Ie under intermittent periodic duty				AC-3的Pe (kW)	不间断工作剩下的Ie(A) Ie under uninterrupted duty	重量 Weight (kg)
				AC-1	AC-2	AC-3	AC-4			
CJ20-10	690	220	10	10	-	10	10	2.2	10	0.353
		380						4		
		660				5.2	5.2			
CJ20-16	690	220	16	16	-	16	16	4.5	16	0.416
		380						7.5		
		660				13	13	11		
CJ20-25	690	220	32	32	-	25	25	5.5	32	0.67
		380						11		
		660				14.5	14.5	13		
CJ20-40	690	220	55	55	-	40	40	11	55	1.32
		380						22		
		660				25	25			
CJ20-63	690	220	80	80	63	63	63	18	80	2.9
		380						30		
		660				40	40	40		
CJ20-100	690	220	125	125	100	100	100	28	125	3
		380						50		
		660				63	63	63		
CJ20-160	690	220	200	200	160	160	160	48	200	5.5
		380						85		
		660				100	100	80		
CJ20-160/11	1140	1140			80	80	80			

适用范围 Application

CJ20系列交流接触器主要用于交流50Hz(或60Hz)、额定工作电压至660V(或1140V)额定工作电流至630A的电力系统中供远距离频繁接通和分断电路，并可与适当的热继电器或电子式保护装置组合成电磁起动器，以保护可能发生过载的电路。

产品符合GB 14048.4和IEC60947-4-1等标准。

CJ20 series AC contactor is suitable for the power system of AC 50Hz or 60Hz, rated working voltage up to 660V or 1140V and rated working current up to 630A, used to make and break circuit frequently in a far distance, while, it can be combined with thermal relay or electronic protection equipment to form into an electromagnetic starter, to protect the circuit against possible overload. The products are in conformity with such standards as GB 14048.4 and IEC 60947-4-1.

续上表

型号 Type	Ui V	Ue V	Ith A	断续周期工作制下的Ie(A) Ie under intermittent periodic duty				AC-3的Pe (kW)	不间断工作剩下的Ie(A) Ie under uninterrupted duty	重量 Weight (kg)
				AC-1	AC-2	AC-3	AC-4			
CJ20-250	690	220	315	315	250	250	250	80	315	10.5
CJ20-250/06	690	660			200	200	160	190		
CJ20-400	690	220	400	400	400	400	400	115	400	11.7
		380					200			
		660			250	250	200	220		
CJ20-630	690	220	630	630	630	630	500	175	630	21.5
		380								
CJ20-630/06	690	660	400	400	400	400	320	350	400	
CJ20-630-11	1140	1140						400		

外形及安装尺寸 Outline & installation size

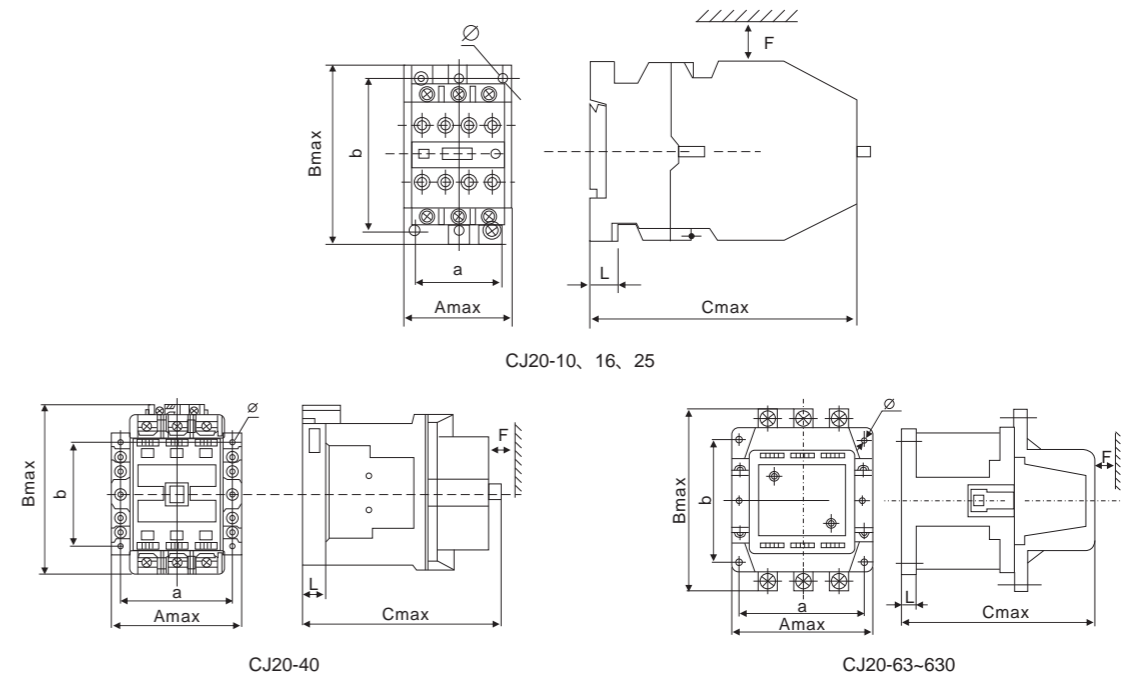

型号 Type	A	B	C	a	b		L	F min
CJ20-10	44.5	67.5	107	35 ± 0.31	55 ± 0.37	5 ^{+0.3} ₀	8	10
CJ20-16	44.5	73	116.5	35 ± 0.31	60 ± 0.37	5 ^{+0.3} ₀	8	10
CJ20-25	53	91	122	40 ± 0.31	80 ± 0.37	5 ^{+0.3} ₀	7.5	10
CJ20-40	87	112.5	125	70 ± 0.37	80 ± 0.37	5 ^{+0.3} ₀	15.5	30
CJ20-63	116	142	146	100 ± 0.36	90 ± 0.36	5.8 ^{+0.3} ₀	13	60
CJ20-100	122	147	154	108 ± 0.435	92 ± 0.435	7 ^{+0.58} ₀	15	70
CJ20-160	146	187	178	130 ± 0.5	130 ± 0.5	9 ^{+0.58} ₀	15	80
CJ20-250	190	235	230	160 ± 0.5	150 ± 0.5	9 ^{+0.58} ₀	17	100
CJ20-400	190	235	230	160 ± 0.5	150 ± 0.5	9 ^{+0.58} ₀	17	110
CJ20-630	245	294	287	210 ± 0.575	180 ± 0.5	11 ^{+0.7} ₀	20	120

CJ40

系列交流接触器

Series AC Contactor



适用范围 Application

CJ40系列交流接触器(以下简称接触器)主要用于交流50Hz或60Hz、额定电压至660V或1140V、电流至1000A的电力系统中接通与分断电路,并可与适当的热继电器或电子式保护装置组合成电动机起动器,以保护可能发生过载的电路。符合标准 GB14048.4, IEC 60947-4-1。

CJ40 AC contactor (hereinafter referred to as contactor) is mainly used in power system of AC 50Hz or 60Hz, and rated voltage up to 660V or 1140V, and rated operating current up to 1000A, for long-distance switching on/off the circuits, and it can be used with appropriate thermal overload relay or electronic protection device in a combined way, in order to protect circuits that may subject to operating overload.

Standard: IEC 60947-4-1.

型号及其含义 Code and implication

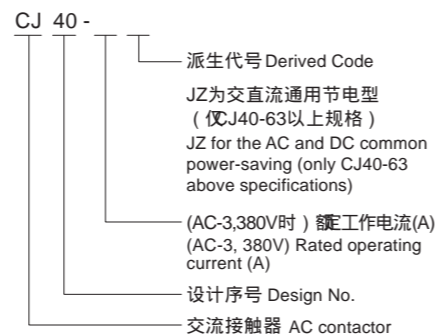

订货须知 Ordering information

订购接触器时,需指明下述各点:

- 接触器完整的名称、型号;
- 线圈的额定工电压和频率或规格代号;
- 辅助触头组合情况,如不指明,63A及以上规格均提供四常开两常闭;
- 订货数量;
- 订货示例: CJ40-63交流接触器,线圈电压380V,50Hz,10台。

When ordering the goods, the user shall indicate the following items:

- Types and names of AC contactor;
- Coil rated operating voltage and frequency or Specification Code;
- Combinations of auxiliary contacts, if not stated, 63A and above Specifications are provided four normally open two normally closed;
- Amount on order;
- Example for ordering: 10 units of CJ40-63 AC contactor, Coil voltage 380V, 50Hz.

主要参数及技术性能 Main technical data

主要参数及技术性能指标(见表1)。main parameters and technical performance (see table1)

表1 Table1

接触器型号 Contactor type	额定绝缘电压 Rated insulation voltage Ui(V)	约定自由空气发热电流Ith(A) Conventional free air thermal current Ith (A)	AC-3使用类别下可控制的三相鼠笼型电动机的最大功率(kW) AC-3 three-phase squirrel cage motors can be controlled under the category of maximum power (kW)				每小时操作循环数 次/h(AC-3) Operating cycles per hour	AC-3电寿命 (万次) Electrical life (10,000 times)	线圈功耗 Coil Power		选用的熔断器 (SCPD)型号 Fuse type		
			220V	380V	660V	1140V			启动 Start (VA)	保持 Latching (VA)			
CJ40-63	1140	80	18.5	30	55	-	1200	120	480	85.5	RT16-160		
CJ40-80			22	37	55	-					RT16-160		
CJ40-100			30	45	75	-					RT16-250		
CJ40-125			37	55	75	55					RT16-250		
CJ40-160		250	45	75	110	-			600	60	880	152	RT16-315
CJ40-200			55	90	110	-							RT16-315
CJ40-250			75	132	110	110							RT16-315
CJ40-315			90	160	300	-							RT16-500
CJ40-400		500	110	220	300	-	300	30			1710	250	RT16-500
CJ40-500			150	280	300	220							RT16-500
CJ40-630			200	335	475	-							RT17-4/630
CJ40-800			250	450	475	-							RT17-4/800
CJ40-1000		1000	1000	360	625	475			600				RT17-4/1250(1000)

辅助触头的组合情况及基本参数(见表2)。Parameters of the auxiliary contacts (see Table 2).

表2 Table2

产品型号规格 Contactor type	约定自由空气发热电流(A) Conventional free air thermal current Ith (A)	额定绝缘电压(V) Rated insulation voltage	额定工作电压(V) Rated operating voltage		额定工作电流(A) Rated operating current		额定控制容量 Rated control capacity		触头种类数量 Contact number of species			
			交流AC	直流DC	交流AC	直流DC	交流AC	直流DC	常开NO	常闭NC	常开NO	常闭NC
CJ40-63~250	10	690	380	220	0.82	0.27	AC-15	DC-13	常开NO	4	3	2
			220	110	1.4	0.6	300VA	60W	常闭NC	2	3	4
CJ40-315~1000	16	690	380	220	1.3	0.27	AC-15	DC-13	常开NO	4	3	2
			220	110	2.3	0.6	500VA	60W	常闭NC	2	3	4

节电产品节电率(见表3)。Saving products saving rate (see Table 3).

表3 Table3

产品型号 Product number	CJ40-63~250JZ	CJ40-315~1000JZ
节电率% Saving rate%	90	90

- 动作条件: 吸合电压: (85%~110%)Us; 释放电压: 普通型的为(20%~75%)Us, 其余的为(10%~75%)Us。
- 线圈控制电源电压Us为: 交流50Hz, 110V, 127V, 220V, 380V; 直流110V, 220V。
- 机械寿命: 250A以下1000万次, 315~500A为600万次, 630~1000A的为300万次。
- Action conditions: pull-in voltage: (85% ~ 110%) Us; release voltage: common type of (20% ~ 75%) Us, the rest of (10% ~ 75%) Us.
- Coil control supply voltage Us as: AC 50Hz, 110V, 127V, 220V, 380V; DC 110V, 220V.
- Mechanical life: 250A or less 10 million times, 315 ~ 500A is 600 million times, 630 ~ 1000A 300 million times.

外形及安装尺寸 Outline & installation size

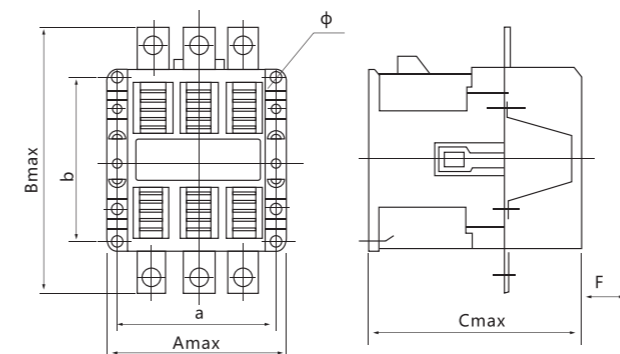

接触器型号 Contactor type	外形尺寸 Dimensions			安装尺寸 Mounting dimensions			安全区域F		
	A	B	C	a	b	∅	380V	660V	1140V
CJ40-63~125	116	143	154	100±0.435	90±0.435	5.8	20	40	40
CJ40-160~200	146	186	184	130±0.5	130±0.5	9	30	40	50
CJ40-250	146	186	184	130±0.5	130±0.5	9	40	60	60
CJ40-315~400	190	235	230	160±0.5	150±0.5	9	40	60	60
CJ40-500	190	235	230	160±0.5	150±0.5	9	50	70	80
CJ40-630~1000	244.5	347	287.5	210±0.575	180±0.5	11	-	-	-

正常工作条件 Normal operating conditions

- 周围空气温度为: -5 +40, 24小时内其平均值不超过+35。
- 海拔高度: 不超过2000m。
- 大气条件: 最高温度+40时, 空气的相对湿度不超过50%; 在较低温度下可以允许有较高的相对湿度, 例如20时达90%。对由于温度变化偶尔产生的凝露应采取特殊的措施。
- 污染等级: 3级。
- 安装类别: Ⅲ类。
- 安装条件: 安装面与垂直面倾斜度不大于±5°。
- 冲击振动: 产品应安装和使用在无显著摇动、冲击和振动的地方。
- Ambient temperature: -5°C~+40°C, the average during 24 hours should not exceed +35°C;
- Altitude: 2000m;
- Atmosphere conditions: At mounting site, relative humidity not exceed 50% at the max temperature of +40°C, higher relative humidity is allowable under lower temperature. for example, RH could be 90% at +20°C, special measures should be taken to occurrence of dew;
- Pollution degree: 3
- Installation category: III
- Installation conditions: the inclination between installation plane and vertical plane is within ±5°
- Impact and shake: the products should locate in the places where there are no obvious impact and shake.

结构特点 Structural features

- 接触器为直动式结构, 触头灭弧系统位于上部、电磁系统位于下部, 触头为双断点、由银合金制成。63A及以上产品有六对辅助触头, 三种组合(见表2)。
- CJ40-63A以上产品灭弧罩采用耐弧塑料和铁质栅片组成, 一方面克服了陶土灭弧罩易碎的缺点, 另一方面具有分断能力高、可靠性高的优点。
- The contactor is of directly acting structure, the contacting and arc quenching system assembled in the top, electromagnetic system located at bottom, the contacts are of dual break point, made of silver alloy. The 63A and above contactors have 6 pairs of auxiliary contacts, three combinations (as table 2).
- The arc quenching chamber of CJ40-63A contactors consist of arcing withstand plastic and steel fence, this can overcome the shortage of easy crack for argil arc quenching system, also achieve the higher interrupting capacity.

CJX1

系列交流接触器

Series AC Contactor



主要技术参数 Main technical data

型号规格 Type	CJX1-9	CJX1-12	CJX1-16	CJX1-22	CJX1-32	CJX1-38	CJX1-45	CJX1-63	CJX1-75	CJX1-85	CJX1-110	CJX1-140	CJX1-170	CJX1-205	CJX1-250	CJX1-300	CJX1-400	CJX1-475		
额定绝缘电压 V Rated insulation Voltage	690													1000						
频率 Frequency (Hz)	50(或60)																			
额定工作电流 A Rated Working current	AC-3 380V		9	12	16	22	32	38	45	63	75	85	110	140	170	205	250	300	400	475
	AC-4 380V		3.3	4.3	7.7	8.5	15.6	18.5	24	28	34	42	54	68	75	96	110	125	150	165
在AC-3使用类别下可控电动机最大功率kW Max power of controllable motor under AC-3 utilization kW	220V		2.2	3	4	5.5	8.5	11	15	18.5	22	28	37	43	55	64	78	93	125	148
	380V		4	5.5	7.5	11	15	18.5	22	30	37	45	55	75	90	110	132	160	200	252
	660V		5.5	7.2	11	11	23	23	39	55	67	67	100	100	156	156	235	235	375	342
约定发热电流 A Conventional thermal current	AC-3		20	20	30	30	55	55	90	80	100	100	160	160	210	220	300	300	400	550
操作频率 次/h Operating frequency	AC-3		1200	1200	1200	1200	600	600	600	600	600	600	300	300	300	300	300	300	300	300
	AC-4		300	300	300	300	300	300	300	300	300	200	200	130	200	130	150	150	150	150
负载因数 On-load factor AC-3	40%																			
与熔断器的组合 Combined with fuse	NT00-16	NT00-20	NT00-25	NT00-32	NT00-50	NT00-63	NT00-63	NT00-80	NT00-100	NT00-125	NT00-160	NT00-200	NT00-250	NT00-250	NT00-315	NT00-400	NT00-500	NT00-500		
与热过载继电器的组合 Combined with thermal overload relay	JRS2-12.5		JRS2-25		JRS2-32		JRS2-45		JRS2-80		JRS2-80		JRS2-180		JRS2-180		JRS2-250		JRS2-400	
吸引线圈工作范围 Working range of pull-in windings	吸引 Attracting	85%Us~110%Us																		
	释放 to release	20%Us~75%Us																		
吸引线圈电压 V Voltage of pull-in windings	24、36、48、110、127、220、380																			
辅助触头约定发热电流 A Conventional thermal current of auxiliary contact	10																			
电寿命/万次 Electrical life	AC-3		100			80			60											
	AC-4		20			15			10											
重量 Weight (kg)	AC-3		0.43	0.49	0.7	1.43	2.21	3.42	5.5	6.8	9.2									

适用范围 Application

CJX1系列交流接触器主要用于交流50Hz(或60Hz)、额定工作电压至1000V,在AC-3使用类别下额定工作电压为380V时额定工作电流至475A的电路中,供远距离接通和分断电路或频繁起动和控制交流电动机,并可适当的与热过载继电器组成电磁起动器,以保护可能发生过载的电路。

产品符合GB14048.4和IEC60947-4-1等标准。

CJX1 series AC contactor is suitable for the circuit of AC 50Hz (or 60Hz) and rated working voltage up to 1000V or the circuit of rated working voltage 380V and rated working current 475A under AC-3 utilization, it is mainly used to make and break circuits in a far distance or frequently start and control AC motors, it also can be formed into an electromagnetic starter with suitable thermal overload relay to protect the circuit against possible overload.

The products are in conformity with such standards as GB14048.4 and IEC60947-4-1.

外形及安装尺寸 Outline & installation size

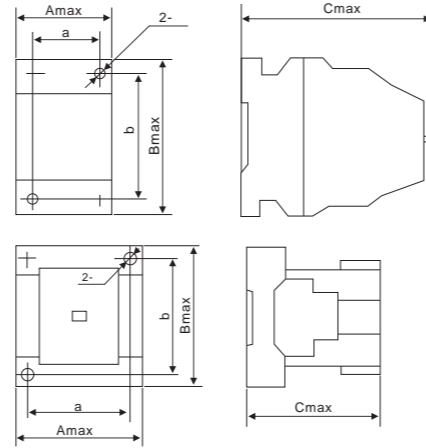

型号 Type	Amax	Bmax	Cmax	a	b	φ
CJX1-9.12	46	79	106	35±0.50	60±0.60	4.8 ^{+0.48} ₀
CJX1-16.22	46	89	116	35±0.50	75±0.60	
CJX1-32	74	90	109	50±0.50	75±0.60	
CJX1-38	82	102	110	45±0.50	75±0.60	5.0 ^{+0.48} ₀
CJX1-45.63	92	120	125	70±0.60	100±0.70	
CJX1-75.85	105	135	145	80±0.60	110±0.70	5.5 ^{+0.48} ₀
CJX1-110.140	125	158	155	100±0.70	130±0.80	6.5 ^{+0.58} ₀
CJX1-170	140	185	190	110±0.70	160±0.80	7.0 ^{+0.58} ₀
CJX1-205	140	185	190	110±0.70	160±0.80	7.0 ^{+0.58} ₀
CJX1-250	146	194	202	120±0.70	180±0.80	9.0 ^{+0.63} ₀
CJX1-300	146	194	202	120±0.70	180±0.80	9.0 ^{+0.63} ₀
CJX1-400	162	205	224	130±0.80	180±0.80	9.0 ^{+0.63} ₀
CJX1-475	162	205	224	130±0.80	180±0.80	9.0 ^{+0.63} ₀

CJX2

系列交流接触器

Series AC Contactor

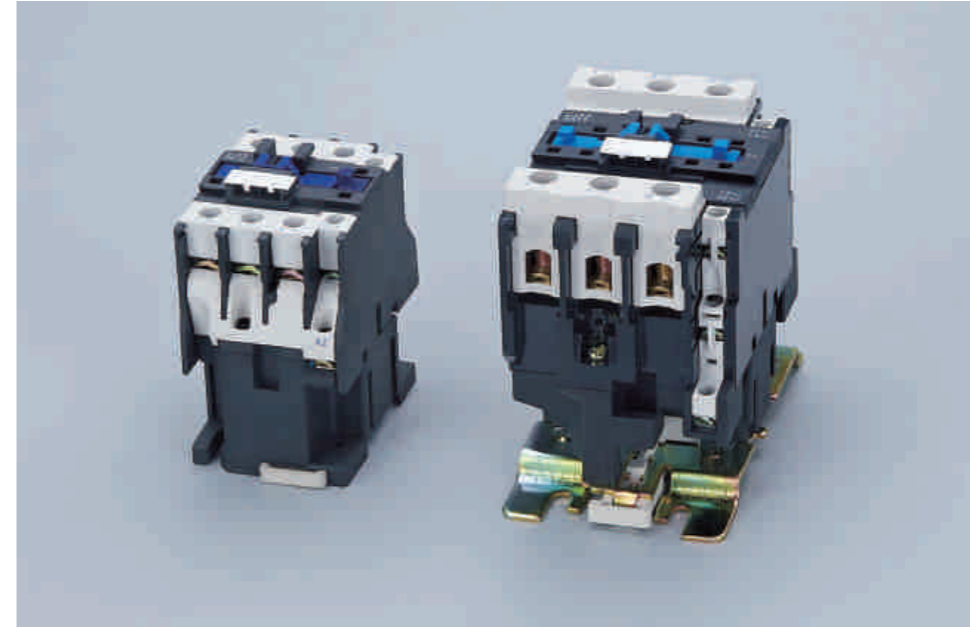

适用范围 Application

CJX2系列交流接触器主要用于交流50Hz或60Hz、额定绝缘电压690V,在AC-3使用类别下,额定工作电压380V、额定工作电流至620A的电力系统中,供远距离接通和分断电路及频繁地起动和控制交流电动机。并可适当的与热过载继电器或电子式保护装置组合成电磁起动器,以保护可能发生过载的电路。

CJX2 series AC contactor is suitable for the power system of AC 50Hz or 60Hz and rated insulation voltage up to 690V or the power system of rated working voltage 380V and rated working current up to 620A under AC-3 utilization, used to make and break circuit in a far distance or to frequently start and control AC motors, while, it can be combined with thermal relay or electronic protection equipment to form into an electromagnetic starter to protect the circuit against possible overload.

主要技术参数 Main technical data

型号 Type		CJX2-09	CJX2-12	CJX2-18	CJX2-25	CJX2-32	CJX2-40	CJX2-50	CJX2-65	CJX2-80	CJX2-95	
额定工作电流 A Rated Working current	380V	AC-3	9	12	18	25	32	40	50	65	80	95
		AC-4	3.5	5	7.7	8.5	12	18.5	24	28	37	44
	660V	AC-3	6.6	5.9	12	18	21	34	39	42	49	55
		AC-4	1.5	2	3.5	4.4	7.5	9	12	14	17.3	21.3
约定发热电流 A Conventional thermal current		20	20	32	40	50	60	80	80	125	125	
可控三相鼠笼电动机功率 AC-3 kW Power of controllable three-phase squirrel cage motor AC-3 kW	220V	2.2	3	4	5.5	7.5	11	15	18.5	22	25	
	380V	4	5.5	7.5	11	15	18.5	22	30	37	45	
	660V	5.5	7.5	9	15	18.5	30	33	37	45	55	
操作频率 次/h Operating frequency	电寿命 Electrical life	AC-3	1200				600					
	AC-4	300										
机械寿命 Mechanical life		3600										
电寿命 / 万次 Electrical life	AC-3	100				80				60		
	AC-4	20				15				10		
机械寿命/万次 Mechanical life		1000				800				600		
熔断器型号 Fuse model		RT16-20	RT16-20	RT16-32	RT16-32	RT16-50	RT16-63	RT16-80	RT16-80	RT16-100	RT16-125	
符合标准 Conform to standard		GB/T14048.1				GB14048.4		IEC 60947-4-1				

CJX2

系列交流接触器

Series AC Contactor

型号 Type		CJX2-115	CJX2-150	CJX2-170	CJX2-205	CJX2-245	CJX2-300	CJX2-410	CJX2-475	CJX2-620	
额定工作 电流A Rated Working current	380V	AC-3	115	150	170	205	245	300	410	475	620
		AC-4	52	60	75	85	105	217	135	147	180
	660V	AC-3	86	107	110	130	170	325	305	355	460
		AC-4	49	61	69	80	90	118	135	145	170
约定发热电流 A Conventional thermal current		250	250	250	275	315	400	500	700	1000	
可控三相鼠笼电动机功率 AC-3 kW Power of controllable three-phase squirrel cage motor AC-3 kW	220V	30	40	55	63	72	100	110	147	200	
	380V	55	75	90	110	132	160	200	265	335	
	660V	80	100	110	129	160	220	280	335	450	
操作频率次/h Operating frequency	电寿命 Electrical life	AC-3	600						300		
	机械寿命 Mechanical life	AC-4	150						2400		
电寿命/万次 Electrical life	AC-3	60			50			30		20	
	AC-4	15			8			5			
机械寿命/万次 Mechanical life		600						500			
配用熔断器型号 Fuse model		RT16-160	RT16-250	RT16-250	RT16-315	RT16-315	RT16-400	RT16-500	RT16-630	RT16-630	
符合标准 Conform to standard		GB/T14048.1		GB14048.4		IEC 60947-4-1					

外形及安装尺寸 Outline & installation size

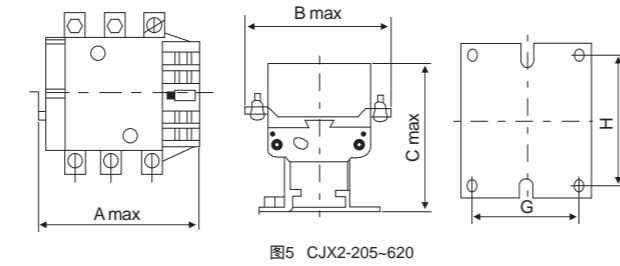
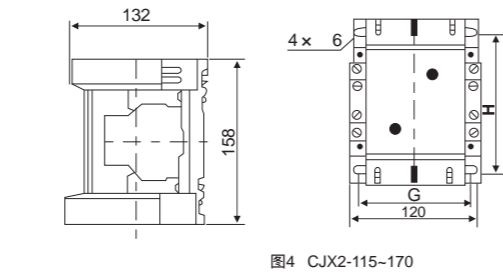
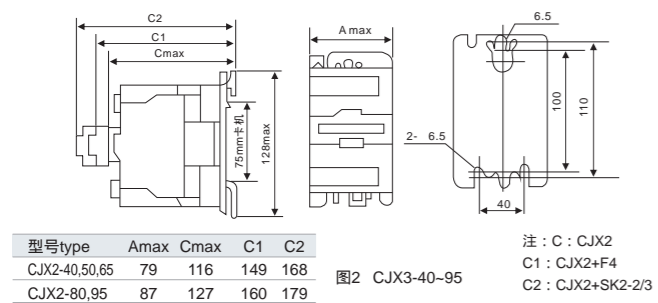
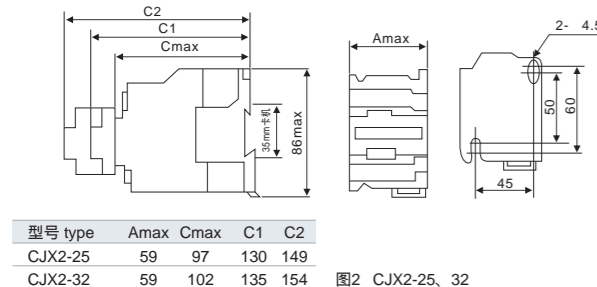
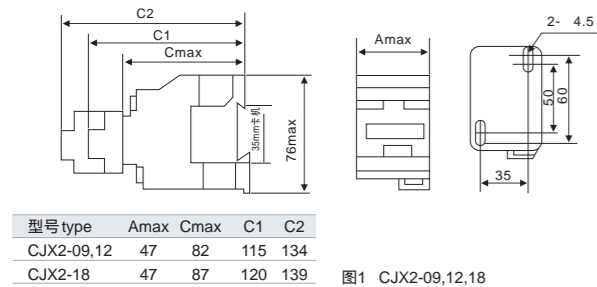

型号 type	Amax	Bmax	Cmax	G	H
CJX2-115/152/170	158	120	132	90/110	130
CJX2-185/205	170	174	185	80	110/120
CJX2-225/245	170	198	185	80	110/120
CJX2-300/330	213	206	219	96	110/120
CJX2-410	213	206	219	80	170/180
CJX2-475	233	238	232	80	170/180
CJX2-620/630	309	304	255	181	180/190

CJX8(B)

系列交流接触器

Series AC Contactor



适用范围 Application

CJX8(B)系列交流接触器主要用于交流50Hz (或60Hz)、额定工作电压至660V，额定工作电流至370A的电力系统中接通和分断电路，并可与适当的热过载继电器或电子式保护装置组合成电磁起动器，以保护可能发生过载的电路。

产品符合GB 14048.4和IEC 60947-4-1等标准。

CJX(B) series AC contactor is suitable for the circuit of AC 50Hz (or 60Hz), rated working voltage up to 660V and rated working current up to 370A, used to make and break circuit in a far distance, it also can be formed into an electromagnetic starter with suitable thermal overload relay to protect the circuit against possible overload.

The products are in conformity with such standards as GB 14048.4 and IEC 60947-4-1.

主要技术参数 Main technical data

- 接触器主电路的基本参数下表。
- 辅助电路：接触器配用的辅助触头有CA7、CA9、CA11型几种型式。CA7型有CA7-0(1常闭)、CA7-10(1常开)，它靠底部楔型槽固定在B9-30接触器动触头支架的楔型凸块上，最多可装4个此类型的辅助触头、常开常闭任意。CA9、CA11型辅助触头有CA9-11(1常开1常闭)、CA9-20(2常开)、CA11-11辅助(1常开1常闭)、CA11-20(2常开)几种。CA9型配用B-37~85，CA11型配用B-105~370，以结构连接方式固定在接触器本体四周的专门部位，每台接触器最多可装4个上述型号的辅助触头。
- Basic parameters of contactor main circuit are shown as the following list.
- Auxiliary circuit: Auxiliary contacts for contactor have several types like CA7, CA9 and CA11, etc., Here into, CA7 type auxiliary contacts have derived types such as CA7-0 (1NC) and CA7-10(1NO), fixed on the wedge lug of B9-30 contactors moving contact holder with the bottom wedge slot. Four auxiliary contacts of such type can be mounted at most, whether NO contact or NC contact is available. CA9 type and CA11 type auxiliary contacts have derived types like CA9-11(1NO1NC), CA9-20(2NO), CA11-11auxiliary (1NO 1 NC), CA11-20(2NO), etc.. CA9 type contacts are for B-37~85 contactors, CA11 type contacts are for B-105~370, they are fastened on the special parts around the contactor body in the structural connection way. Each contactor may be mounted with four auxiliary contacts of above-mentioned types at most.

型号 Type	框架 代号 Frame code	额定绝 缘电压 Ui V Rated insulation Voltage	约定发热 电流 Ith A Conventional thermal current	AC-3、AC-4使用类别 AC-3 and AC-4 utilization category				操作频率 次/h Operating frequency time/h	
				额定工作电流 Ie A Rated working current		可控制电动机的最大功率 kW Max power of controllable motor		AC-3	AC-4
				380V	660V	380V	660V		
CJX8(B)-9	16	690	16	8.5	3.5	4	3	600	300
CJX8(B)-12	16	690	20	11.5	4.9	5.5	4	600	300
CJX8(B)-16	16	690	25	15.5	3.7	7.5	5.5	600	300
CJX8(B)-25	25	690	40	22	13	11	11	600	300
CJX8(B)-30	30	690	45	30	17.5	15	15	600	300
CJX8(B)-37	45	690	45	37	21	18.5	18.5	600	300
CJX8(B)-45	45	690	60	44	25	22	22	600	300
CJX8(B)-65	85	690	80	65	44	33	40	600	300
CJX8(B)-85	85	690	100	85	55	45	50	600	300
CJX8(B)-105	105	690	140	105	82	55	75	600	150
CJX8(B)-170	170	690	230	170	118	90	110	600	150
CJX8(B)-250	250	690	300	245	170	132	160	400	100
CJX8(B)-370	370	690	410	370	268	200	250	400	100

CJX8(B)

系列交流接触器

Series AC Contactor

外形及安装尺寸 Outline & installation size



图1 CJX8(B)-9, 12, 16



图2 CJX8(B)-25

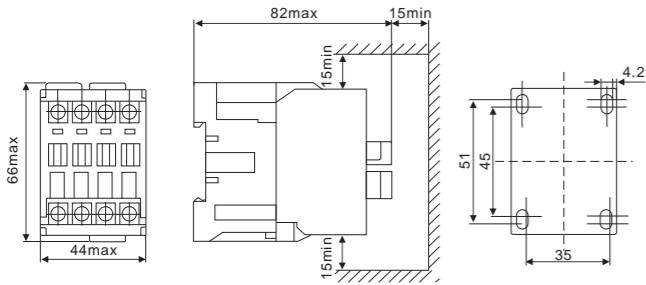

图3 CJX8(B)-30

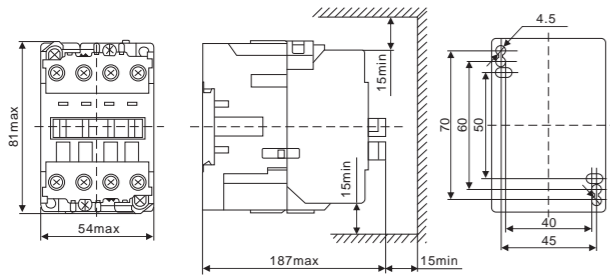

图4 CJX8(B)-37, 45

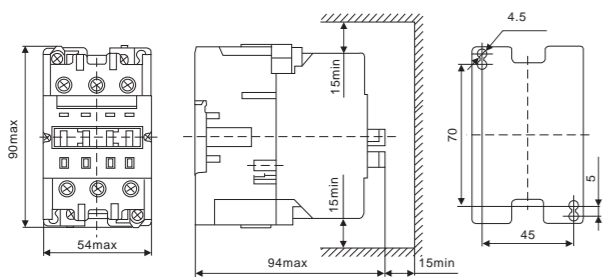

图5 CJX8(B)-65, 85

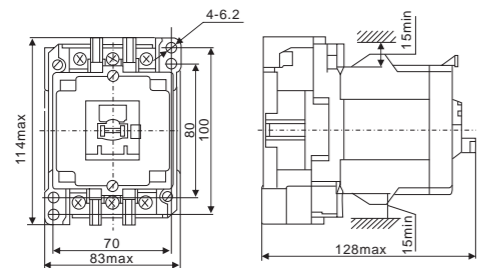

图6 CJX8(B)-105, 170, 250, 370

型号 Type	A	B	C	D	E	F	G	H min
	max							
CJX8(B)-105	118	154	137	140	35	6.5	6.5	15
CJX8(B)-170	134	165	152	150	40	6	7.5	15
CJX8(B)-250	167	207	193	190	50	7	8.5	15
CJX8(B)-370	202	252	221	220	60	7	8.5	15

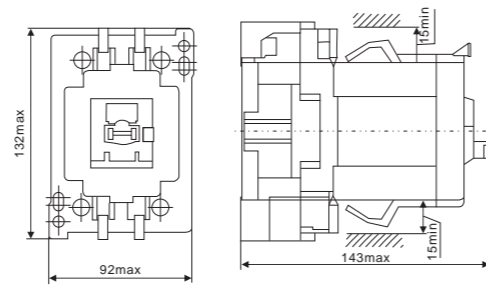
HD/HS

系列开启式刀开关及刀形转换开关

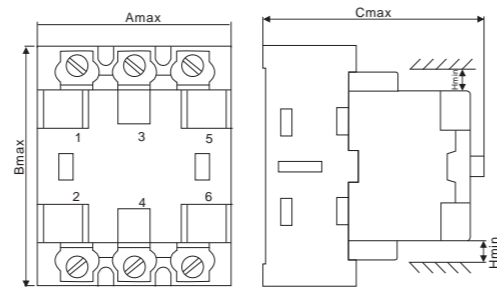
Open-type knife switch and blade switch

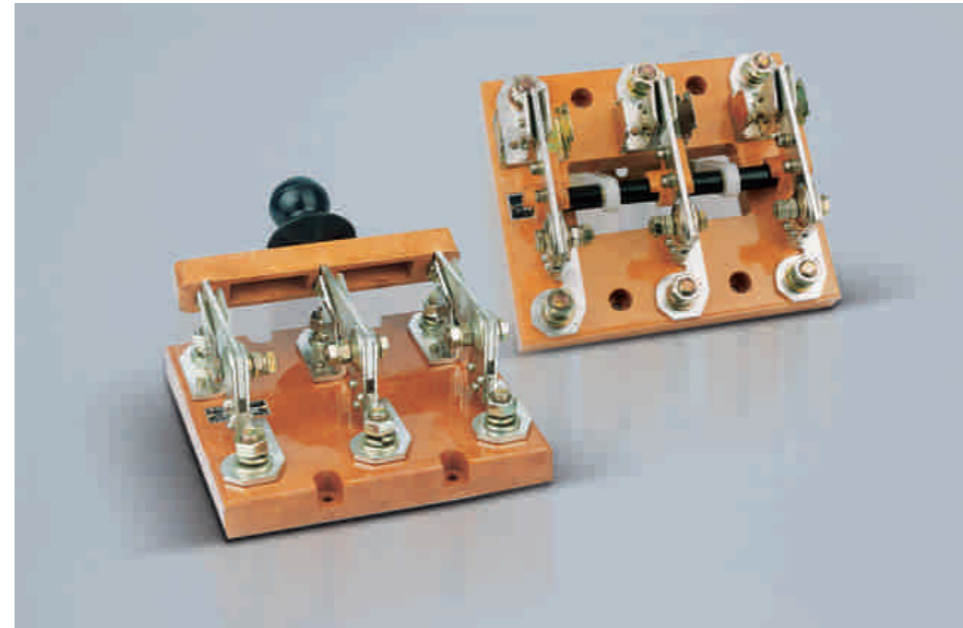

型号及含义 Type and meaning

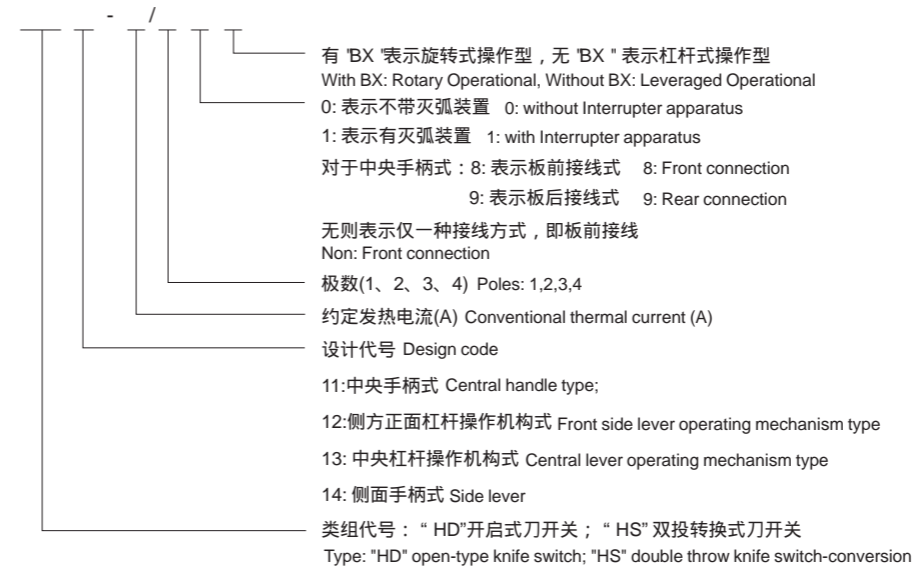

正常工作条件 Normal operating conditions

- 周围空气温度不高于+40℃, 不低于-5℃。
- 安装地点的海拔不超过2000m。
- 湿度: 最高温度为+40℃时, 空气的相对湿度不超过50%, 在较低的温度下可以允许有较高的相对湿度, 例如20℃时达90%。对由于温度变化偶尔产生的凝露应采取特殊的措施。
- 周围环境的污染等级为3级。
- 开关应安装在无显著震动、冲击振动和没有雨雪侵袭的地方, 同时安装地点应无爆炸危险介质, 且介质中无足以腐蚀金属和破坏绝缘的气体及尘埃。
- Ambient temperature: -5℃~+40℃
- Altitude: 2000m;
- When the ambient air temperature is +40℃, the relative humidity of the air shall not be higher than 50%; a higher relative humidity is allowed at a lower temperature; for example, for the wettest month, the maximum relative humidity averaged shall be 90% while the lowest temperature averaged in that month +20℃, and special measures shall be taken for the condensation occasionally produced due to temperature change.
- Pollution degree: 3
- The ambient air is not significantly polluted by dust, smoke, corrosive and/or flammable gases, vapours or salt.

适用范围 Application

HD系列、HS系列开启式刀开关及刀形转换开关(以下简称开关)适用于交流50Hz、额定电压至380V、直流至220V, 额定电流至3000A的成套配电装置中, 作为不频繁地手动接通和分断交、直流电路或作隔离开关用。其中:

- 中央手柄式的开关主要用于动力站, 不切断带有电流的电路, 作为隔离开关之用。
 - 侧方正面杠杆操作机构式开关主要用于正面操作、前面维修的开关柜中, 操作机构可以在柜的两侧安装。
 - 中央正面杠杆操作机构开关主要用于正面操作、后面维修的开关柜中, 操作机构装在正前方。
 - 侧面操作手柄式开关, 主要用于动力箱中。
 - 装有灭弧室的开关可以切断适当的电流负荷, 其他系列刀开关只作隔离开关使用。
- 符合标准: GB 14048.3、IEC 60947-3。

HD knife switch and knife-shaped transfer switch (hereinafter referred to as the switch) is applicable for the complete set of distribution unit with the AC frequency of 50Hz, rated current up to 380V and the rated current up to 3000A, to turn on and off the AC and DC circuit in an infrequent manner or serve as isolation switch

- Central handle switch is mainly used in the power station to serve as an isolation switch. It will not cut off the live circuit.
- Side front lever operating mechanism switches for front operation, front switchgear maintenance, operating mechanism cabinet mounted on both sides
- Central front lever operating mechanism switch is mainly used for switchgear cabinet of frontal maintenance from behind, and the operating mechanism is installed dead ahead.
- Switch with a side handle is mainly used in power box.
- Switch with an interrupter switch can cut off proper current load, while other series of knife switches can only serve as isolation switch.

HD/HS 系列开启式刀开关及刀形转换开关 Open-type knife switch and blade switch



主要参数及技术性能 Main technical data

- 额定工作电压为交流380V、直流220V。Rated working voltage AC 380V, DC 220V.
- 主要技术性能及参数 (见表)。Main technical performance and parameters (see Table 1).

表1 Table 1

约定发热电流(A) Conventional thermal current	100	200	400	600	1000	1500	2000	3000
额定工作电流(A) Rated operating current	100	200	400	600	1000	1500	2000	3000
通断能力(A) Breaking capacity	AC 380V、 $\cos \phi=0.72-0.8$ DC T=0.01-0.011S 220V							
机械寿命(次) Mechanical life (times)	10000	10000	10000	5000	5000	5000	3000	3000
电寿命(次) Electrical life (times)	1000	1000	1000	500	500	500	300	300
1S短时耐受电流(kA) 1S short time withstand current	6	10	20	25	30	40	50	50
动稳定电流峰值(kA) Peak withstand current	操作机构式 Operating mechanism type							
	手柄式 Handle							
操作力(N) Operating force	300	300	400	400	400	400	400	400

外形及安装尺寸 Outline & installation size

- HD11板前接线 (见图、表2)。Front connection for HD11(See Figure 1, Table 2)



图1 Figure 1

表2 Table 2

型号 Model	规格 Type	100A		200A			400A				600A				
		2P	3P	1P	2P	3P	4P	1P	2P	3P	4P	1P	2P	3P	4P
HD11 中央手柄式 板前接线 开启式 刀开关	A	90	130	100	190	190	270	120	190	210	300	140	240	260	360
	B	210	210	210	210	210	230	270	270	270	300	350	350	330	330
	C	-	40	60	120	70	140	80	160	80	160	100	200	100	200
	D	140	140	140	140	140	140	190	190	190	190	140	140	140	140
	E	50	40	-	70	70	70	-	80	80	80	-	100	100	100
	F	165	165	165	165	165	165	215	215	215	215	274	274	274	274
HD11 Knife switch of Central lever type for front connection	H	210	220	220	220	220	240	270	270	270	300	330	330	310	310
	h	110	120	120	120	120	120	135	135	135	145	140	140	125	125
	J	110	110	110	110	110	110	146	146	146	146	234	234	234	234
	K	-	-	-	-	-	-	-	-	-	-	40	40	40	40
	O	-	-	-	-	-	-	-	-	-	-	-	-	-	-
	P	-	-	-	-	-	-	-	-	-	-	-	-	-	-
	M	8	8	8	8	8	8	12	12	12	12	16	16	16	16
		7	7	7	7	7	7	7	7	7	7	9	9	9	9

续表2 Continued Table 2

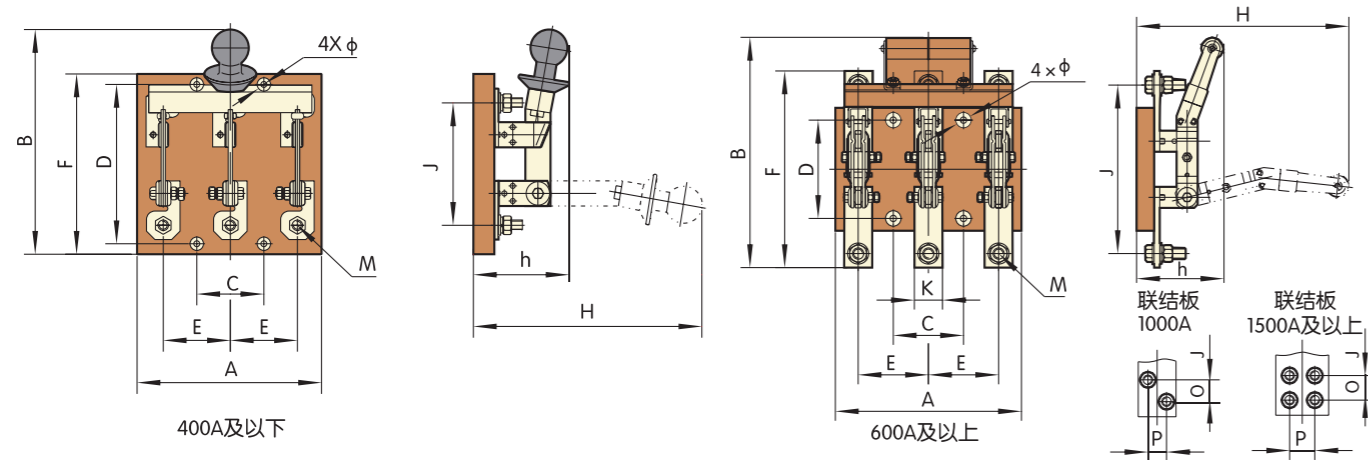
型号 Model	规格 Type	1000A				1500A				2000A				3000A(2500A)			
		1P	2P	3P	4P	1P	2P	3P	4P	1P	2P	3P	4P	1P	2P	3P	4P
HD11 中央手柄式 板前接线 开启式 刀开关	A	160	280	320	440	170	300	350	480	240	400	500	680	260	460	600	800
	B	380	380	360	360	410	410	390	390	420	420	420	420	450	450	450	450
	C	120	240	120	240	130	260	130	260	180	360	180	360	200	400	200	400
	D	140	140	140	140	140	140	140	140	140	140	140	140	140	140	140	140
	E	-	120	120	120	-	130	130	130	-	180	180	180	-	200	200	200
HD11 Knife switch of Central lever type for front connection	F	284	284	284	284	330	330	330	330	320	320	320	320	365	365	365	365
	H	380	380	360	360	390	390	370	370	380	380	380	380	390	390	390	390
	h	175	175	160	160	175	175	160	160	170	170	170	170	180	180	180	180
	J	208	208	208	208	230	230	230	230	204	204	204	204	230	230	230	230
	K	50	50	50	50	70	70	70	70	100	100	100	100	120	120	120	120
	O	25	25	25	25	35	35	35	35	40	40	40	40	45	45	45	45
	P	25	25	25	25	35	35	35	35	55	55	55	55	68	68	68	68
	M	12	12	12	12	12	12	12	12	12	12	12	12	16	16	16	16
		9	9	9	9	9	9	9	9	9	9	9	9	11	11	11	11

- HD12外形及安装尺寸见图2, 表3 HD12 Dimensions (See Figure 2, Table 3)



图2 Figure 2

表3 Table 3

型号 Model	规格 Type	100A、200A			400A			600A			1000A		1500A	
		2P	3P	4P	2P	3P	4P	2P	3P	4P	2P	3P	2P	3P
HD12 侧方正面 杠杆操作 机构式 开启式 刀开关	A	200	280	360	220	310	400	250	330	430	300	400	330	440
	B	200	200	200	210	210	210	294	294	294	314	314	354	354
	C	160	80	160	180	90	180	200	100	200	240	120	260	130
	D	160	160	160	160	160	160	160	160	160	160	160	160	160
	E	80	80	80	90	90	90	100	100	100	120	120	130	130
	G	40	40	40	30	30	30	30	30	30	30	30	30	30
	H	80	80	80	90	90	90	95	95	95	110	110	110	110
	J	130	130	130	166	166	166	254	254	254	238	238	254	254
HD12 Knife switch of lever operating mechanism type for front side	K	-	-	-	-	-	-	40	40	40	50	50	70	70
	L	75	75	75	75	75	75	80	80	80	80	80	80	80
	O	-	-	-	-	-	-	-	-	-	25	25	35	35
	P	-	-	-	-	-	-	-	-	-	25	25	35	35
	R	180	180	180	180	180	180	180	180	180	230	230	230	230
	M	8	8	8	12	12	12	16	16	16	12	12	12	12
		7	7	7	7	7	7	9	9	9	9	9	9	9

HD/HS 系列开启式刀开关及刀形转换开关 Open-type knife switch and blade switch

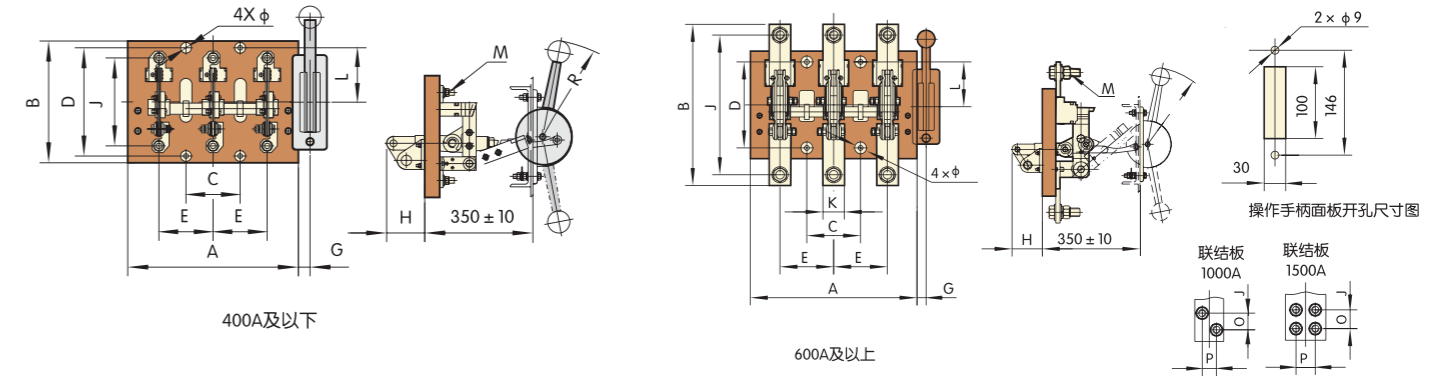

● HD13外形及安装尺寸见图3，表4 HD13 Dimensions (See Figure 3, Table 4)

● HS13外形及安装尺寸见图4，表5 HD13 Dimensions (See Figure 4, Table 5)



图3 Figure 3

图4 Figure 4

表4 Table 4

型号 Model	规格 Type	100A、200A			400A			600A			1000A		
		2P	3P	4P	2P	3P	4P	2P	3P	4P	2P	3P	4P
HD13 中央杠杆 操作机构式 开启式 刀开关	A	190	210	300	220	245	335	240	260	360	280	320	460
	B	200	200	200	210	210	210	294	294	294	314	314	314
	C	160	80	160	180	90	180	200	100	200	240	120	240
	D	160	160	160	160	160	160	160	160	160	160	160	160
	E	80	80	80	90	90	90	100	100	100	120	120	120
HD13 Knife switch of Central lever operating mechanism type	G前	350~370			350~370			350~370			350~370		
	G后	245~265			245~265			245~265			245~265		
HD13 Knife switch of Central lever operating mechanism type	H	160	160	160	185	185	185	190	190	190	230	230	230
	J	130	130	130	166	166	166	254	254	254	238	238	238
	K	-	-	-	-	-	-	40	40	40	50	50	50
	L	75	75	75	75	75	75	80	80	80	80	80	80
	O	-	-	-	-	-	-	-	-	-	25	25	25
	P	-	-	-	-	-	-	-	-	-	25	25	25
	R	180	180	180	180	180	180	180	180	180	230	230	230
	S	100	100	100	100	100	100	100	100	100	100	100	100
	T	146	146	146	146	146	146	146	146	146	146	146	146
	M	8	8	8	12	12	12	16	16	16	12	12	12

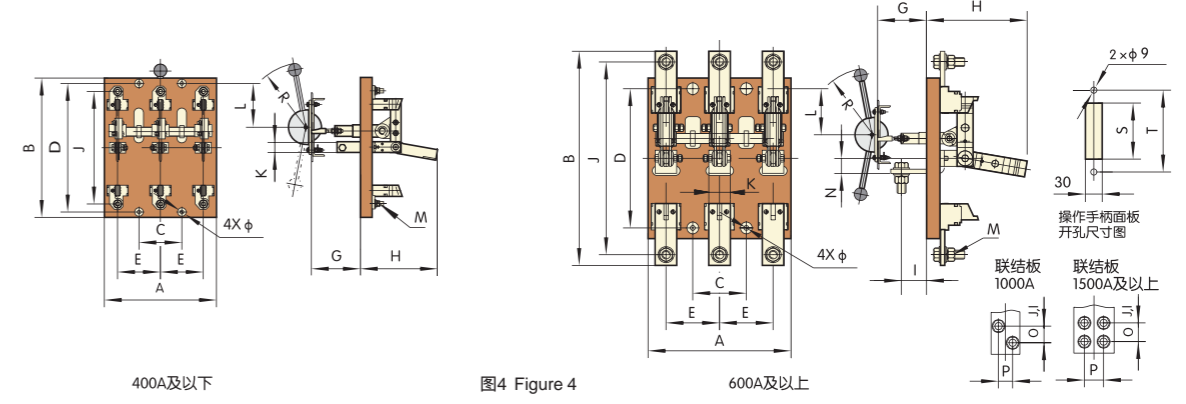
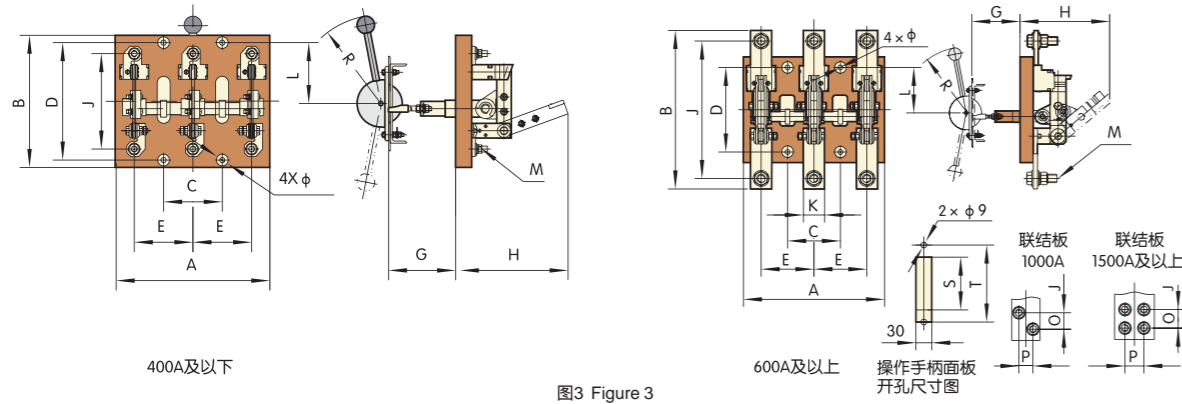
续表4 Continued Table 4

型号 Model	规格 Type	1500A			2000A			3000A(2500A)		
		2P	3P	4P	2P	3P	4P	2P	3P	4P
HD13 中央杠杆 操作机构式 开启式 刀开关	A	310	350	510	450	450	680	520	520	800
	B	354	354	354	360	360	360	400	400	400
	C	260	130	260	170	170	360	190	190	400
	D	160	160	160	160	160	160	160	160	160
	E	130	130	130	340	170	180	380	190	200
HD13 Knife switch of Central lever operating mechanism type	G前	350~370			350~370			350~370		
	G后	245~265			245~265			245~265		
HD13 Knife switch of Central lever operating mechanism type	H	235	235	235	230	230	230	235	235	235
	J	254	254	254	244	244	244	264	264	264
	K	70	70	70	100	100	100	120	120	120
	L	80	80	80	80	80	80	80	80	80
	O	35	35	35	40	40	40	45	45	45
	P	35	35	35	55	55	55	68	68	68
	R	230	230	280	280	280	280	280	280	280
	S	100	100	130	130	130	130	140	140	140
	T	146	146	164	164	164	164	180	180	180
	M	12	12	12	12	12	12	16	16	16

注：G前：为板前操作安装距离，G后：为板后操作安装距离

表5 Table 5

型号 Model	规格 Type	100A、200A			400A			600A			1000A		
		2P	3P	4P	2P	3P	4P	2P	3P	4P	2P	3P	4P
HS13 中央杠杆 操作机构式 刀形 转换开关	A	190	210	300	220	245	335	240	260	360	280	330	450
	B	280	280	280	300	300	300	394	394	394	434	434	434
	C	160	80	160	180	90	180	200	100	200	240	120	240
	D	240	240	240	240	240	240	240	240	240	240	240	240
	E	80	80	80	90	90	90	100	100	100	120	120	120
	G	245~265			245~265			245~265			245~265		
	H	160	160	160	185	185	185	190	190	190	235	235	235
	I	35	35	35	26	26	26	36	36	36	36	36	36
	J	210	210	210	256	256	256	354	354	354	358	358	358
	K	-	-	-	-	-	-	40	40	40	50	50	50
HS13 Blade switch of Central lever operating mechanism type	L	75	75	75	70	70	70	70	70	70	60	60	60
	N	-	-	-	-	-	-	30	30	30	40	40	40
	O	-	-	-	-	-	-	-	-	-	25	25	25
	P	-	-	-	-	-	-	-	-	-	25	25	25
	R	180	180	180	180	180	180	180	180	180	230	230	230
	S	100	100	100	100	100	100	100	100	100	100	100	100
	T	146	146	146	146	146	146	146	146	146	146	146	146
	M	8	8	8	8	8	8	16	16	16	12	12	12

续表5 Continued Table 5

型号 Model	规格 Type	1500A			2000A			3000A(2500A)		
		2P	3P	4P	2P	3P	4P	2P	3P	4P
HS13 中央杠杆 操作机构式 刀形 转换开关	A	310	370	510	500	500	680	600	600	800
	B	504	504	504	480	480	480	540	540	540
	C	260	130	260	180	180	360	200	200	400
	D	280	280	280	240	240	240	280	280	280
	E	130	130	130	180	180	180	200	200	200
HS13 Blade switch of Central lever operating mechanism type	G	245~265			245~265			245~265		
	H	255	255	255	235	235	235	260	260	260
	I	32	32	32	48	48	48	50	50	50
	J	404	404	404	370	370	370	404	404	404
	K	70	70	70	100	100	100	120	120	120
	L	70	70	70	60	60	60	70	70	70
	N	46	46	46	50	50	50	50	50	50
	O	35	35	35	40	40	40	45	45	45
	P	35	35	35	55	55	55	68	68	68
	R	280	280	280	280	280	280	280	280	280
S	130	130	130	130	130	130	140	140	140	
T	164	164	164	164	164	164	180	180	180	
M	12	12	12	12	12	12	16	16	16	

HD/HS 系列开启式刀开关及刀形转换开关

Open-type knife switch and blade switch



● HD13-/BX外形及安装尺寸见图5, 表6 HD13-/BX Dimensions (See Figure 5, Table 6)

● HS13-/BX外形及安装尺寸见图5, 表6 HS13-/BX Dimensions (See Figure 6, Table 7)



图5 Figure 5

图6 Figure 6

表6 Table 6

型号 Model	规格 Type	100A、200A			400A			600A			1000A		
		2P	3P	4P	2P	3P	4P	2P	3P	4P	2P	3P	4P
HD13-/BX 中央旋转 操作机构式 开启式 刀开关	A	190	210	300	220	245	335	240	260	360	280	320	460
	B	200	200	200	210	210	210	294	294	294	314	314	314
	C	160	80	160	180	90	180	200	100	200	240	120	240
	D	160	160	160	160	160	160	160	160	160	160	160	160
	E	80	80	80	90	90	90	100	100	100	120	120	120
	H	160	160	160	185	185	185	190	190	190	230	230	230
HD13-/BX Knife switch of Rotary operating mechanism type	J	130	130	130	166	166	166	254	254	254	238	238	238
	K	-	-	-	-	-	-	40	40	40	50	50	50
	L	125	125	125	125	125	125	135	135	135	137	137	137
	O	-	-	-	-	-	-	-	-	-	25	25	25
	P	-	-	-	-	-	-	-	-	-	25	25	25
	M	8	8	8	12	12	12	16	16	16	12	12	12

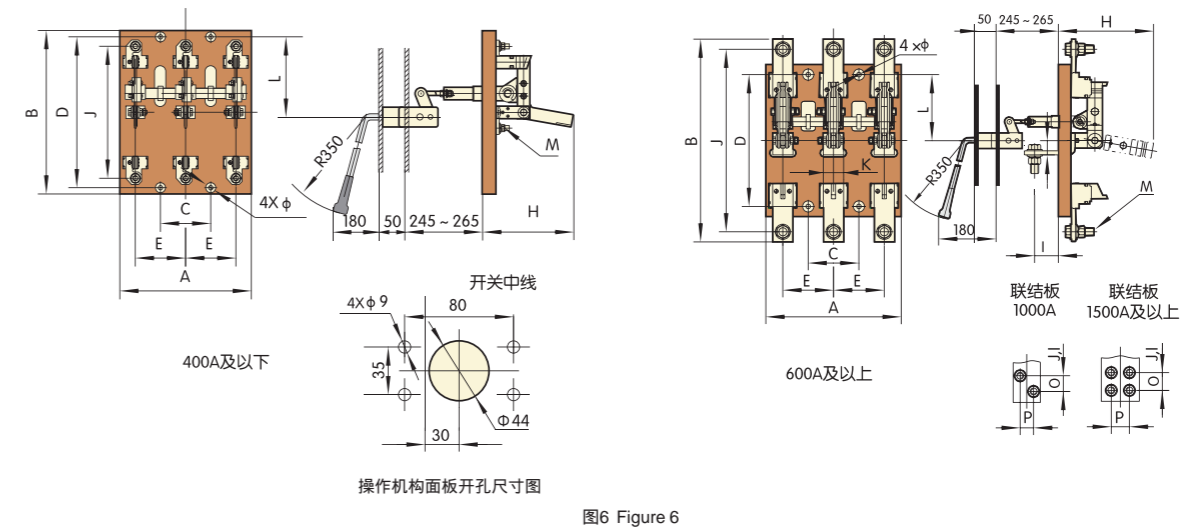
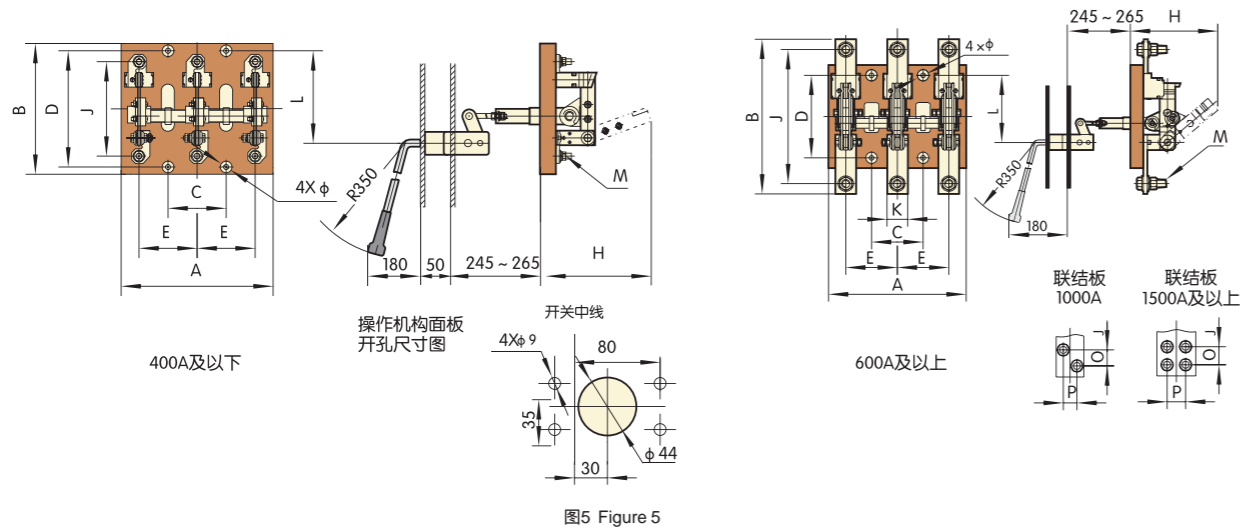
续表6 Continued Table 6

型号 Model	规格 Type	1500A			2000A			3000A(2500A)		
		2P	3P	4P	2P	3P	4P	2P	3P	4P
HD13-/BX 中央旋转 操作机构式 开启式 刀开关	A	310	350	510	450	450	680	520	520	800
	B	354	354	354	360	360	360	400	400	400
	C	260	130	260	170	170	360	190	190	400
	D	160	160	160	160	160	160	160	160	160
	E	130	130	130	340	170	180	380	190	200
	H	235	235	235	230	230	230	235	235	235
HD13-/BX Knife switch of Rotary operating mechanism type	J	254	254	254	244	244	244	264	264	264
	K	70	70	70	100	100	100	120	120	120
	L	137	137	137	137	137	137	137	137	137
	O	35	35	35	40	40	40	45	45	45
	P	35	35	35	55	55	55	68	68	68
	M	12	12	12	12	12	12	16	16	16

表7 Table 7

型号 Model	规格 Type	100A、200A			400A			600A			1000A		
		2P	3P	4P	2P	3P	4P	2P	3P	4P	2P	3P	4P
HS13-/BX 中央旋转 操作机构式 刀开 转换开关	A	190	210	300	220	245	335	240	260	360	280	330	450
	B	280	280	280	300	300	300	394	394	394	434	434	434
	C	160	80	160	180	90	180	200	100	200	240	120	240
	D	240	240	240	240	240	240	240	240	240	240	240	240
	E	80	80	80	90	90	90	100	100	100	120	120	120
	H	160	160	160	185	185	185	190	190	190	235	235	235
HS13-/BX Knife open Switch of Rotary operating mechanism type	I	35	35	35	26	26	26	36	36	36	36	36	36
	J	210	210	210	256	256	256	354	354	354	358	358	358
	K	-	-	-	-	-	-	40	40	40	50	50	50
	L	125	125	125	120	120	120	125	125	125	117	117	117
	N	-	-	-	-	-	-	30	30	30	40	40	40
	O	-	-	-	-	-	-	-	-	-	25	25	25
HS13-/BX Knife open Switch of Rotary operating mechanism type	P	-	-	-	-	-	-	-	-	-	25	25	25
	M	8	8	8	12	12	12	16	16	16	12	12	12
		7	7	7	7	7	7	9	9	9	9	9	9

续表7 Continued Table 7

型号 Model	规格 Type	1500A			2000A			3000A(2500A)		
		2P	3P	4P	2P	3P	4P	2P	3P	4P
HS13-/BX 中央旋转 操作机构式 刀开 转换开关	A	310	370	510	500	500	680	600	600	800
	B	504	504	504	480	480	480	540	540	540
	C	260	130	260	180	180	360	200	200	400
	D	280	280	280	240	240	240	280	280	280
	E	130	130	130	180	180	180	200	200	200
	H	255	255	255	235	235	235	260	260	260
HS13-/BX Knife open Switch of Rotary operating mechanism type	I	32	32	32	48	48	48	50	50	50
	J	404	404	404	370	370	370	404	404	404
	K	70	70	70	100	100	100	120	120	120
	L	127	127	127	117	117	117	127	127	127
	N	46	46	46	50	50	50	50	50	50
	O	35	35	35	40	40	40	45	45	45
HS13-/BX Knife open Switch of Rotary operating mechanism type	P	35	35	35	55	55	55	68	68	68
	M	12	12	12	12	12	12	16	16	16
		9	9	9	11	11	11	13	13	13

HD11F/HS11F 系列保护型开启式刀开关 Protection type open-type knife switch

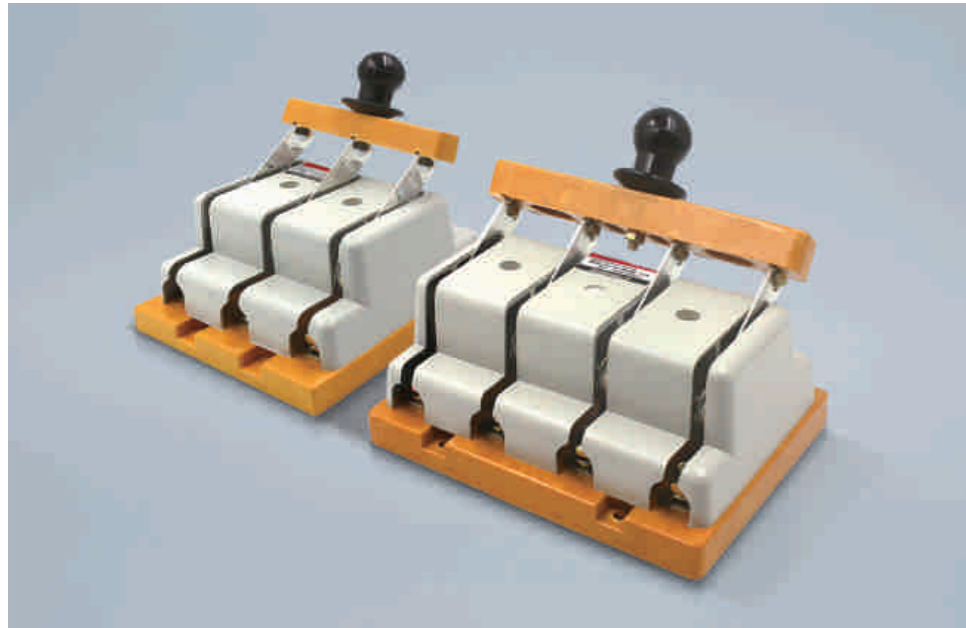

型号及含义 Type and meaning

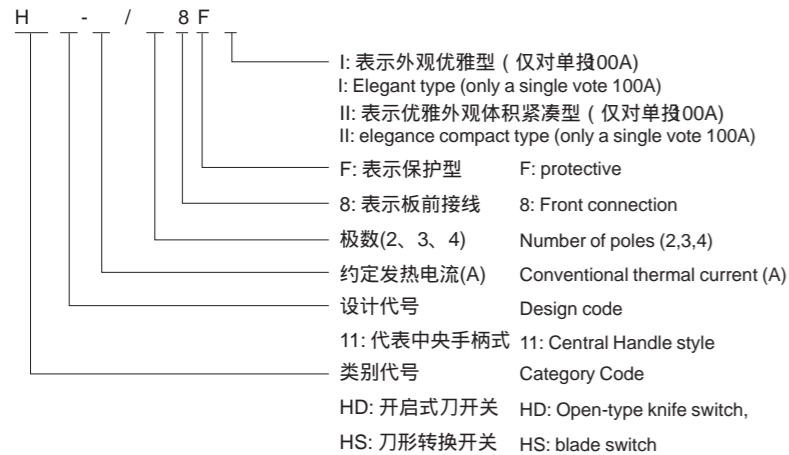

主要参数及技术性能 Main technical data

- 额定工作电压为交流380V、直流220V。Rated working voltage AC 380V, DC 220V.
- 主要技术性能及参数 (见表1)。Main technical performance and parameters (see Table 1).

表1 Table 1

约定发热电流(A) Conventional thermal current	100	200	400	600	1000
额定工作电流(A) Rated operating current	100	200	400	600	1000
通断能力(A) Breaking capacity	AC 380V, $\cos \phi = 0.72-0.8$	100	200	400	600
	DC T=0.01~0.011S 220V	100	200	400	600
机械寿命(次) Mechanical life (times)	10000	10000	10000	5000	3000
电寿命(次) Electrical life (times)	1000	1000	1000	500	300
1S短时耐受电流(kA) 1S short time withstand current	6	10	20	25	30
动稳定电流峰值(kA) Peak withstand current	15	20	30	40	50
操作力(N) Operating force	300	300	400	400	450

适用范围 Application

HD11F和HS11F系列单投和双投保护型刀开关是我公司在HD11、HS11基础上派生新开发产品,是HD11、HD11F、HS11的理想替代产品,极大的提高对人身安全防护性能,防止误触电。该系列产品主要用于低压配电设备中,作不频繁地手动接通和切断、隔离电源之用。符合标准:GB 14048.3、IEC 60947-3。

HD11F and HS11F series single and double break protective blade switch, is developed by our company on basis of the HD11、HS11 series switch. They are the ideal replacement device for HD11、HD11F、HS11, greatly improve the protective safety to personnel, prevent wrongly electric shock. This series of switch is mainly assembled in low voltage switchgear, used to switch on/off, disconnect the power source. It complies with the standard of GB 14048.3、IEC 60947-3

正常工作条件

Normal operating conditions

- 周围空气温度不高于+40℃, 不低于-5℃。
 - 安装地点的海拔不超过2000m。
 - 湿度: 最高温度为+40℃时, 空气的相对湿度不超过50%, 在较低的温度下可以允许有较高的相对湿度, 例如20℃时达90%。对由于温度变化偶尔产生的凝露应采取特殊的措施。
 - 周围环境的污染等级为3级。
- 开关应安装在无显著摇动、冲击振动和没有雨雪侵袭的地方, 同时安装地点应无爆炸危险介质, 且介质中无足以腐蚀金属和破坏绝缘的气体及尘埃。

- Ambient temperature: -5℃~+40℃
- Altitude: 2000m;
- When the ambient air temperature is +40℃, the relative humidity of the air shall not be higher than 50%; a higher relative humidity is allowed at a lower temperature; for example, for the wettest month, the maximum relative humidity averaged shall be 90% while the lowest temperature averaged in that month +20℃, and special measures shall be taken for the condensation occasionally produced due to temperature change.
- Pollution degree: 3
- The ambient air is not significantly polluted by dust, smoke, corrosive and/or flammable gases, vapours or salt.

外形及安装尺寸 Outline & installation size

- HD11F板前接线 (见图、表2)。Front connection for HD11F(See Figure 1, Table 2)



图1 Figure 1

表2 Table 2

型号 Model	规格 Type	100			200			400			600	1000	100 I型	100 II型	
		2P	3P	4P	2P	3P	4P	2P	3P	4P	3P	3P	4P	3P	4P
HD11F保护型板前接线开启式刀开关 HD11F Open-type knife switch of Protective type for front connection	A	90	130	270	200	200	270	200	220	300	290	322	200	120	160
	B	210	210	230	210	210	230	270	270	300	330	350	210	170	170
	C	-	40	140	140	70	140	160	80	160	100	115	100	40	80
	D	140	140	140	140	140	140	190	190	190	140	140	140	100	100
	E	50	50	70	70	70	70	80	80	80	100	115	50	40	40
	F	165	165	165	165	165	165	215	215	215	260	275	158	125	125
	H	220	220	240	220	220	240	270	270	300	305	335	210	185	185
	h	110	120	120	120	120	120	135	135	145	125	160	110	90	90
	M	8	8	8	8	8	8	12	12	12	16	12	8	6	6
			7	7	7	7	7	7	7	7	9	9	7	7	7

- HS11F板前接线 (见图、表3)。Front connection for HS11F(See Figure 2, Table 3)

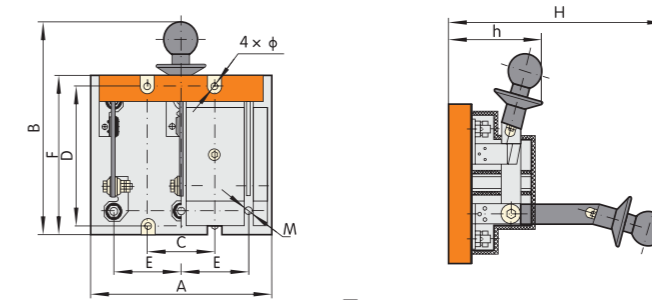

图2 Figure 2

表3 Table 3

型号 Model	规格 Type	100			200			400		
		2P	3P	4P	2P	3P	4P	2P	3P	4P
HS11F保护型板前接线开启式刀开关 HS11F Open-type knife switch of Protective type for front connection	A	78	140	170	200	200	270	210	210	300
	B	245	290	300	330	330	370	440	440	440
	C	-	40	80	70	70	140	160	80	160
	D	112	120	120	220	220	220	280	280	280
	E	40	50	40	140	70	70	80	80	80
	F	165	165	165	245	245	245	312	312	312
	H	180	190	200	240	240	240	280	280	300
	h	70	70	70	100	100	100	110	110	110
	M	-	-	-	8	8	8	8	8	8
			7	7	7	7	7	7	7	7

订货须知 Ordering Information

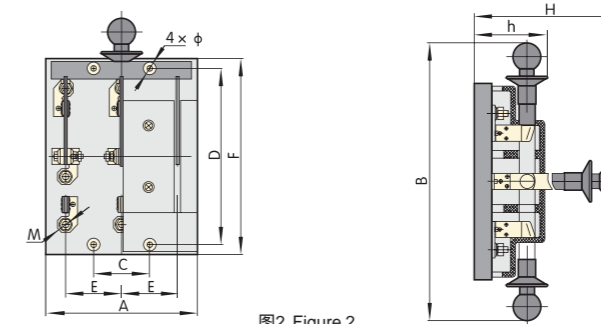
订货单位须注明开关的型式特征, 电压等级, 电流等级, 极数, 操作方式及数量等, 特殊订货请咨询我公司技术部门。例如: HD11F-200/38B, 380V, 10台。
Shall specify the type of feature order unit switches, voltage level, current level, very few, operating mode and quantity, special orders, please consult our technical department.
For example: HD11F-200 / 38B, 380V, 10 units.

HR3 系列熔断器式隔离开关 Series fuse switch disconnecter

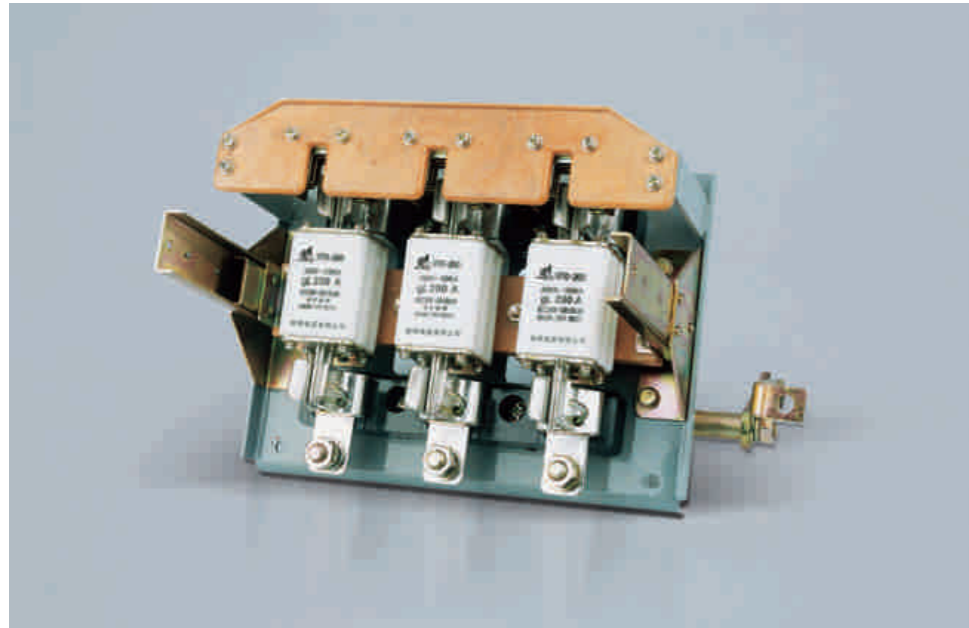

型号及含义 Type and meaning



表1 Table 1

约定发热电流(A) Conventional thermal current	额定工作电流(A) Rated operating current	AC380V			
		HR3正面侧方 杠杆传动机构式 Front side of lever-type transmission mechanism	HR3正面中央 杠杆传动机构式 Central side of lever-type transmission mechanism	HR3侧面 操作手柄式 Side operating handle type	HR3无面板正面侧方 杠杆传动机构式 Without plate front side of lever-type transmission mechanism
100	100	HR3-100/31	HR3-100/32	HR3-100/33	HR3-100/34
200	200	HR3-200/31	HR3-200/32	HR3-200/33	HR3-200/34
400	400	HR3-400/31	HR3-400/32	HR3-400/33	HR3-400/34
600	600	HR3-600/31	HR3-600/32	HR3-600/33	HR3-600/34
1000	1000		HR3-1000/32	HR3-1000/33	HR3-1000/34

表2 Table 2

型号 Model	额定工作电压 Rated operating voltage Ue(V)	额定绝缘电压 Rated insulation voltage Ui(V)	约定发热电流 Conventional thermal current Ith(A)	额定工作电流 Rated operating current Ie(A)	熔断器型号 Fuse type	额定限制 短路电流KA Rated short-circuit current limit
HR3-100	380	500	100	100	RT0-100	50
HR3-200			200	200	RT0-200	50
HR3-400			400	400	RT0-400	50
HR3-600			600	600	RT0-600	50
HR3-1000			1000	1000	RT0-1000	50

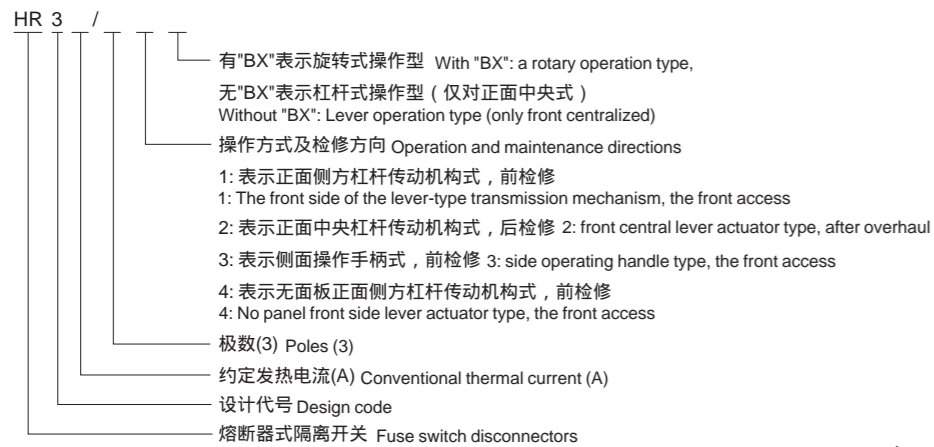
适用范围 Application

HR3系列熔断器式隔离开关适用于交流50Hz、380V, 额定电流至1000A的配电系统中作为短路保护和电缆, 导线的过载保护之用。在正常情况下, 可供不频繁地手动接通和分断正常负载电流与过载电流, 在短路情况下, 由熔断器分断电流。符合标准: GB 14048.3、IEC 60947-3。

HR3 series fuse switch-disconnector with fuse is applicable in the circuit of AC50Hz, rated voltage AC380V and below, rated current up to 1000A. HR3 series are infrequently manually operated multipolar fuse combination switches, They break or switch off on load and provide safely isolation and protection against overcurrent for any voltage electrical circuit. Standard: IEC/EN 60947-3.

正常工作条件

Normal operating conditions

- 周围空气温度不高于+40, 不低于-5。
- 安装地点的海拔不超过2000m。
- 湿度: 最高温度为+40 时, 空气的相对湿度不超过50%, 在较低的温度下可以允许有较高的相对湿度, 例如20 时达90%。对由于温度变化偶尔产生的凝露应采取特殊的措施。
- 周围环境的污染等级为3级。
- 开关应安装在无显著摇动、冲击振动和没有雨雪侵袭的地方, 同时安装地点应无爆炸危险介质, 且介质中无足以腐蚀金属和破坏绝缘的气体和尘埃。

- Ambient temperature: -5°C~+40°C
- Altitude: 2000m;
- When the ambient air temperature is +40°C, the relative humidity of the air shall not be higher than 50%; a higher relative humidity is allowed at a lower temperature; for example, for the wettest month, the maximum relative humidity averaged shall be 90% while the lowest temperature averaged in that month +20°C, and special measures shall be taken for the condensation occasionally produced due to temperature change.
- Pollution degree: 3
- The ambient air is not significantly polluted by dust, smoke, corrosive and/or flammable gases, vapours or salt.

结构特征 Structure

- 熔断器式隔离开关 (以下简称开关) 是熔断器和刀开关的组合电器, 具有熔断器和刀开关的基本性能, 在电路正常供电的情况下, 接通和切断电源由刀开关来担任。当线路或用电设备过载或短路时, 熔断器的熔体烧断, 及时切断故障电流。前操作前检修的开关, 中央有供检修和更换熔断器的门, 主要供BDL配电屏上安装。前操作后检修的开关主要供BSL配电屏上安装。侧操作前检修的开关可以制成封闭的动力配电箱。
- 额定电流1000A及以下的刀开关带有安全挡板, 并装有灭弧室。灭弧室是酚醛布板和钢板冲制件铆合而成的。
- 开关的熔断器固定在带弹簧、锁板的绝缘横梁上, 在正常运行时, 保证熔断器不脱扣, 而当熔断体因线路故障而熔断后, 只需要按下锁板可以很方便地更换熔断器。

- Fused disconnect switch (hereinafter abbreviated as switch) is the combination device of fuse and blade switch, with the basic features of fuse and blade switch, under normal power supply, blade switch is used to perform switching on/off, while the line or the downstream equipment has overloading or short circuit fault, the fuse will be melt and cut off the fault current punctually. The switch of front operated and front repaired will be assembled with a door for repair and replacement, mainly assembled in BDL panel. The switch of front operated and rear repair is mainly assembled in BSL panel. The switch of side operated front repaired can be assembled in power distribution box.
- Blade switches of rated current 1000A and below have safety plate and arc quenching chamber, the later made of phenol aldehyde laminated cloth board and steel plate being riveted.
- The fuse fixed on the insulated crossarm with spring and locking plate, the fuse will not trip during normal servicing, when fuse is melt down due to fault, it is very easy to replace the fuse link after locking plate is pushed down.

外形及安装尺寸 Outline & installation size

- HR3/31系列开关外形及安装尺寸见图1, 表3 HR3/31 Dimensions (See Figure 1, Table 3)



图1 Figure 1

表3 Table 3

型号 Type	外形尺寸 Dimensions									
	A	B	C	D	E	F	H	J	M	
HR3-100/31	400	400	360	360	60	275	266	162	8	
HR3-200/31	400	400	360	360	70	275	266	176	10	
HR3-400/31	400	400	360	360	80	275	266	194	12	
HR3-600/31	450	400	410	360	90	325	266	218	16	

- HR3/32系列开关外形及安装尺寸见图2, 表4 HR3/32 Dimensions (See Figure 2, Table 4)

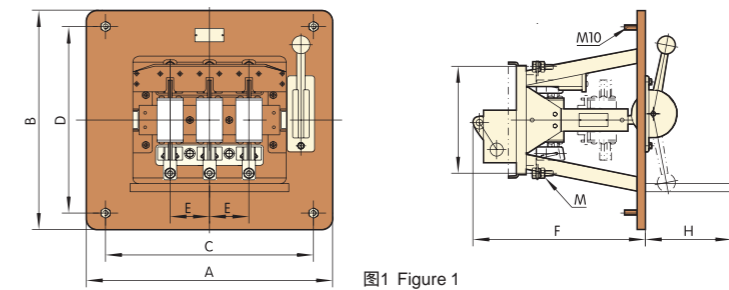

图2 Figure 2

表4 Table 4

型号 Type	外形尺寸 Dimensions									
	A	B	C	D	E	H	J	R	M	
HR3-100/32	250	170	210	130	60	190	162	180	8	
HR3-200/32	270	170	230	130	70	193	176	180	10	
HR3-400/32	290	170	250	130	80	194	194	180	12	
HR3-600/32	320	180	280	130	90	213	218	180	16	
HR3-1000/32	410	310	348	248	115	280	276	230	12	

HR3 系列熔断器式隔离开关 Series fuse switch disconnecter

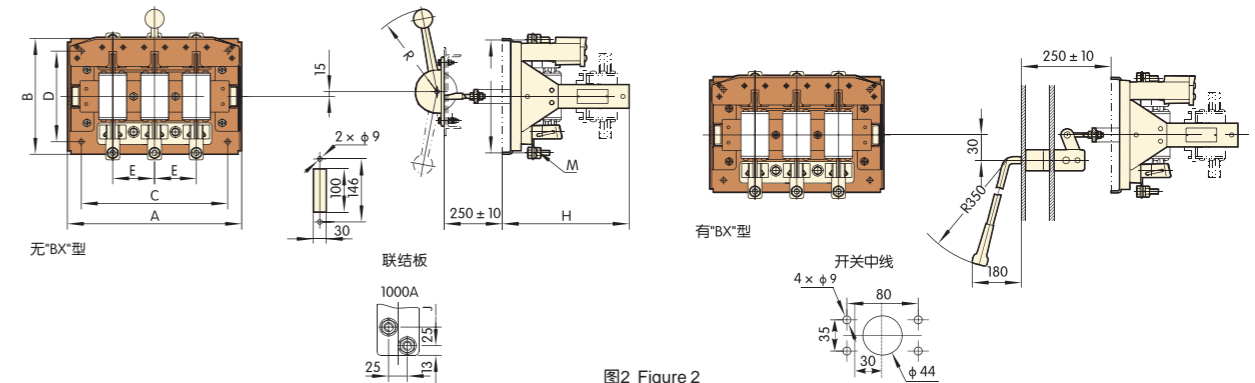
● HR3/33系列开关外形及安装尺寸见图3, 表5 HR3/33 Dimensions (See Figure 3, Table 5)



图3 Figure 3

表5 Table 5

型号 Type	外形尺寸 Dimensions										
	A	B	C	D	E	F	G	H	J	M	
HR3-100/33	250	200	210	170	60	77	68	190	162	8	7
HR3-200/33	270	205	230	170	70	77	60	193	176	10	7
HR3-400/33	290	290	250	170	80	77	55	194	194	12	7
HR3-600/33	320	320	280	170	90	94	50	214	218	16	7

* 注 F尺寸为手柄打开90°使连杆处于最大位置时的尺寸。

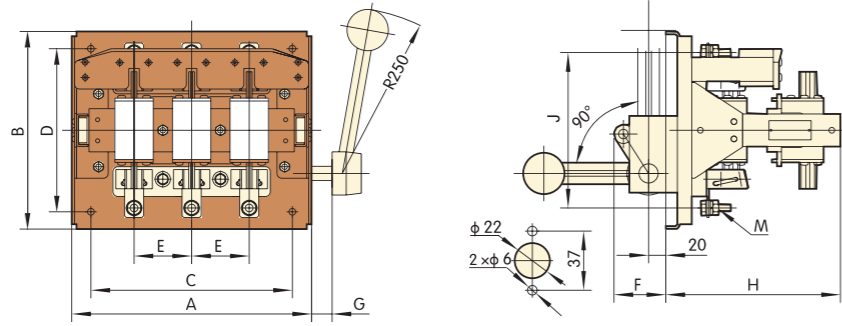
● HR3/34系列开关外形及安装尺寸见图4, 表6 HR3/34 Dimensions (See Figure 4, Table 6)



图4 Figure 4

表6 Table 6

型号 Type	外形尺寸 Dimensions											
	A	B	C	D	E	F	G	H	R	J	M	
HR3-100/34	250	200	210	170	60	80	43	250	180	162	8	7
HR3-200/34	270	205	230	170	70	80	53	250	180	176	10	7
HR3-400/34	290	225	250	170	80	80	43	250	180	194	12	7
HR3-600/34	320	265	280	170	90	95	43	250	180	218	16	7
HR3-1000/34	410	352	348	248	115	115	65	350	230	276	12	8.5

* 注 F尺寸为开关合闸时使连杆处于最大位置的尺寸。

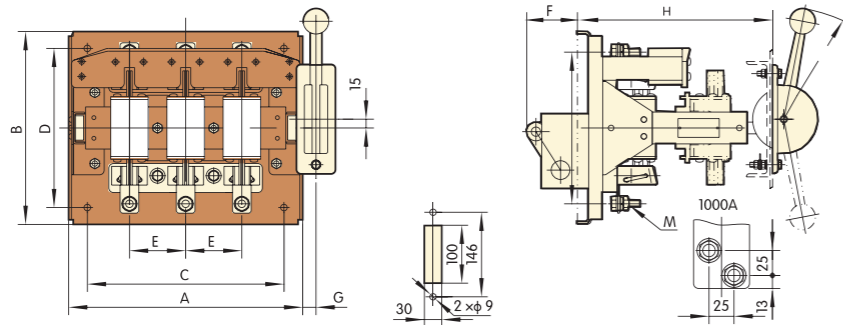
订货须知 Ordering Information

订货单位须注明开关的型式特征, 电压等级, 电流等级, 极数, 操作方式及数量等, 特殊订货请咨询我公司技术部门。例如: HD3-200/32, 380V熔断器电流100A, 10台。
Shall specify the type of feature order unit switches, voltage level, current level, very few, operating mode and quantity, special orders, please consult our technical department.
For example: HD3-200 / 32, 380V fuse current 100A, 10 units.

HR5 系列熔断器式隔离开关 Series fuse switch disconnecter



型号及含义 Type and meaning

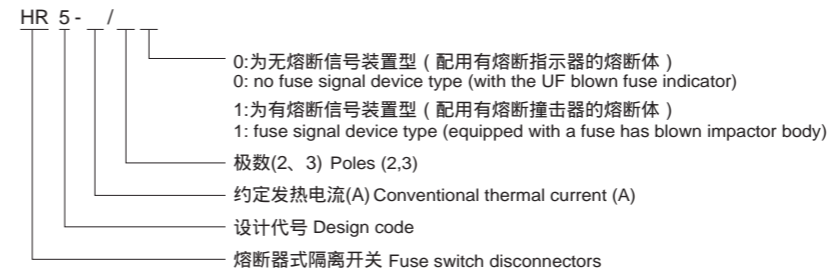

主要参数及技术性能 Main technical data

- 额定绝缘电压: 690V。
- 额定工作电压: 380V、660V两种;
- 额定工作电流: 380V: 100A, 200A, 400A, 630A四种;
660V: 100A, 200A, 315A, 425A四种。
- 开关的接通和分断能力和额定熔断短路电流 (见表1)。
- 开关的机械寿命分别为3000次(100A, 200A)和1000次(400A, 630A)。
- 开关的电寿命分别为600次(100A, 200A)和200次(400A, 630A)接通与分断条件 (见表2)
- 辅助开关(Lx19K)的额定工作电压交流380V, 额定发热电流5A, 额定控制容量300VA。
- Rated insulation voltage: 690V.
- Rated operating voltage: 380V, 660V;
- Rated working current: 380V: 100A, 200A, 400A, 630A;
660V: 100A, 200A, 315A, 425A.
- Making and breaking capacity and rated short-circuit current fuse (see Table 1).
- Mechanical life is 3,000 times (100A, 200A) and 1000 (400A, 630A).
- Electrical life of 600 times (100A, 200A) and 200 (400A, 630A) making and breaking conditions (Table 2)
- Auxiliary switch (Lx19K) rated working voltage AC 380V, rated thermal current 5A, rated control capacity of 300VA.

表1 Table 1

额定工作电压 Rated operating voltage Ue V	约定发热电流 Conventional thermal current Ith A	额定工作电流 Rated operating current Ie A	使用类别 Use category	额定接通和分断能力 Rated making and breaking capacity						额定限制短路电流 Rated short-circuit current limit			
				接通 Making			分断 Breaking			操作循环数 Operating cycles	电流有效值(kA) RMS current	COS	通断次数 OFF times
				I/Ie	U/Ue	COS	IC/Ie	Ur/Ue	COS				
380	100	100	AC-23B	10	1.05	0.45	8	1.05	0.45	5	100	0.25	各1次
	200	200	AC-23B	10	1.05	0.35	8	1.05	0.35	3	100	0.25	各1次
	400	400	AC-23B	10	1.05	0.35	8	1.05	0.35	3	100	0.25	各1次
	630	630	AC-23B	10	1.05	0.35	8	1.05	0.35	3	100	0.25	各1次
660	100	100	AC-22B	3	1.05	0.65	3	1.05	0.65	5	50	0.25	各1次
	200	200	AC-22B	3	1.05	0.65	3	1.05	0.65	5	50	0.25	各1次
	400	315	AC-22B	3	1.05	0.65	3	1.05	0.65	5	50	0.25	各1次
	630	425	AC-22B	3	1.05	0.65	3	1.05	0.65	5	50	0.25	各1次

适用范围 Application

HR5系列熔断器式隔离开关 (以下简称开关) 主要用于额定电压交流380V和660V(45-62Hz), 约定发热电流至630A的具有高短路电流的配电电路和电动机电路中, 作为电源开关、隔离开关、应急开关, 并作为电路保护用, 但一般不作为直接开闭单台电动机之用。

符合标准: GB14048.3、IEC60947-3。

HR5 fuse-switch disconnecter (hereinafter referred to as the switch) is mainly used in the distribution circuit with high short-circuit current and motor circuit where the rated voltage is AC 380V and 660V (45 to 62Hz), the conventional thermal current is up to 630A to serve as power switch, switch disconnecter, emergency switch and exert the function of circuit protection, but is generally not used to directly open and close a single motor.

Standard: IEC/EN 60947-3.

正常工作条件

Normal operating conditions

- 周围空气温度不高于+40℃, 不低于-5℃。
- 安装地点的海拔不超过2000m。
- 湿度: 最高温度为+40℃时, 空气的相对湿度不超过50%, 在较低的温度下可以允许有较高的相对湿度, 例如20℃时达90%。对由于温度变化偶尔产生的凝露应采取特殊的措施。
- 周围环境的污染等级为3级。
- 开关应安装在无显著振动、冲击振动和没有雨雪侵袭的地方, 同时安装地点应无爆炸危险介质, 且介质中无足以腐蚀金属和破坏绝缘的气体及尘埃。
- Ambient temperature: -5℃~+40℃
- Altitude: 2000m;
- When the ambient air temperature is +40℃, the relative humidity of the air shall not be higher than 50%; a higher relative humidity is allowed at a lower temperature; for example, for the wettest month, the maximum relative humidity averaged shall be 90% while the lowest temperature averaged in that month +20℃, and special measures shall be taken for the condensation occasionally produced due to temperature change.
- Pollution degree: 3
- The ambient air is not significantly polluted by dust, smoke, corrosive and/or flammable gases, vapours or salt.

HR5

系列熔断器式隔离开关

Series fuse switch disconnecter

表2 Table 2

额定工作电压(V) Rated operating voltage	使用类别 Use category	接通 ON	接通 ON	接通 ON	分断 OFF	分断 OFF	分断 OFF
		I/le	U/Ue	COS	Ic/Ie	Ur/Ue	COS
380	AC-23B	1	1	0.65	1	1	0.65
660	AC-22B	1	1	0.8	1	1	0.80

● 开关与熔断器配合关系(见表3)。Switch and fuse equipped with relations(see table3)

表3 Table 3

开关约定发热电流(A) Conventional thermal current	熔断器型号 Fuse type	熔体电流值(A) Fuse current
100	NT00, RT16-00	4, 6, 10, 16, 20, 25, 32, 35, 40, 50, 63, 80, 100, 125, 160
200	NT1, RT16-1	80, 100, 125, 160, 200, 224, 250
400	NT2, RT16-2	125, 160, 200, 224, 250, 300, 315, 355, 400
630	NT3, RT16-3	315, 355, 400, 425, 500, 630

注：当开关用于启动电动机中，允许熔体额定电流大于开关约定发热电流。

外形及安装尺寸 Outline & installation size

● HR5系列开关外形及安装尺寸见图1,2, 表4 HR5 Dimensions (See Figure 1,2, Table 4)



图1 HR5-100/20, 30, 31



图2 HR5-200-400-630/20, 30, 31

表4 Table 4

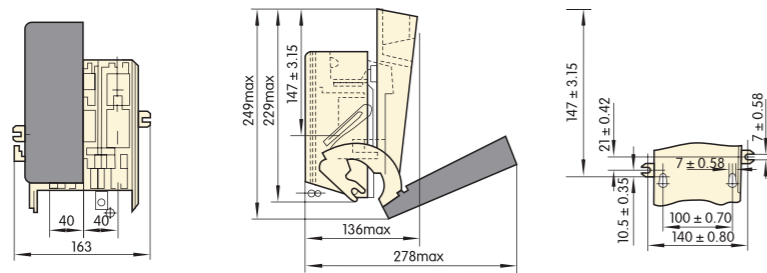
型号 Type	额定发热电流(A) Rated thermal current	外形尺寸 Dimensions					
		a	b	c	d	e	f(安装孔距)
HR5-200/31	200	220±3.60	203±1.45	(62)	193±3.60	342±4.45	130±0.80
HR5-200/30	200	220±3.60	203±1.45	62	193±3.60	342±4.45	130±0.80
HR5-200/20	200	220±3.60	203±1.45	62	193±3.60	342±4.45	130±0.80
HR5-400/31	400	243±3.60	226±1.45	(70)	209±3.60	358±4.45	130±0.80
HR5-400/30	400	243±3.60	226±1.45	70	209±3.60	358±4.45	130±0.80
HR5-400/20	400	243±3.60	226±1.45	70	209±3.60	358±4.45	130±0.80
HR5-630/31	630	289±4.05	227±1.60	(85)	224±3.60	373±4.45	200±0.925
HR5-630/30	630	289±4.05	227±1.60	85	224±3.60	373±4.45	200±0.925
HR5-630/20	630	289±4.05	227±1.60	85	224±3.60	373±4.45	200±0.925

订货须知 Ordering Information

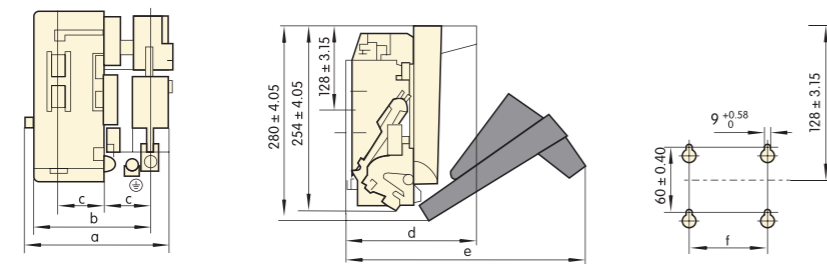
订货单位须注明开关的型式特征，电压等级，电流等级，极数，操作方式及数量等，特殊订货请咨询我公司技术部门。HR5-100/31 380V熔断器电流8A, 10台。
Shall specify the type of feature order unit switches, voltage level, current level, very few, operating mode and quantity, special orders, please consult our technical department.
For example: HR5-100/31, 380V fuse current 8A, 10 units.

HR6

系列熔断器式隔离开关

Series fuse switch disconnecter



型号及含义 Type and meaning

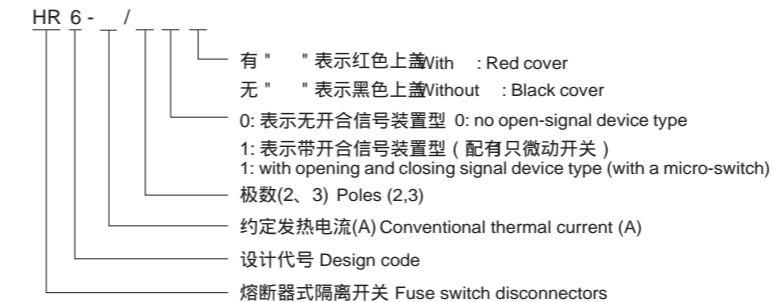

主要参数及技术性能 Main technical data

● 开关与熔断器配合关系(见表1)。Switch and fuse equipped with relations(see table1)

表1 Table 1

约定发热电流(A) Conventional thermal current	熔断器型号 Fuse type	额定工作电压(V) Rated operating voltage	熔体电流值(A) Fuse current
160	NT00, RT16-00	380	4, 6, 10, 16, 20, 25, 32, 35, 40, 50, 63, 80, 100, 125, 160
		660	4, 6, 10, 16, 20, 25, 32, 35, 40, 50, 63, 80, 100
250	NT1, RT16-1	380	80, 100, 125, 160, 200, 224, 250
		660	80, 100, 125, 160, 200
400	NT2, RT16-2	380	125, 160, 200, 224, 250, 300, 315, 355, 400
		660	125, 160, 200, 224, 250, 300, 315
630	NT3, RT16-3	380	315, 355, 400, 425, 500, 630
		660	315, 355, 400, 425

● 开关技术参数(见表2) Switch technical parameters (see Table 2)

表2 Table 2

型号 Type		HR6-160	HR6-250	HR6-400	HR6-630
额定绝缘电压(V) Rated insulation voltage		660	660	660	660
约定发热电流(A) Conventional thermal current		160	250	400	630
额定工作电流(A) Rated current	380V	160	250	400	630
	660V	100	200	315	425
额定接通和分断能力(A) (1.05Ue时) Rated making and breaking capacity (A) (at 1.05Ue)	380V, COS =0.35	接通 ON	1600	2500	4000
		分断 OFF	1280	2000	3200
	660V, COS =0.65	接通 ON	480	750	1200
		分断 OFF	480	750	1200
额定限制短路电流(kA) Rated short-circuit current limit	380V	100	100	100	100
	660V	50	50	50	50

适用范围 Application

HR6系列熔断器式隔离开关(以下简称开关)主要用于额定电压交流380V和660V(45~62Hz),约定发热电流至630A的具有高短路电流的配电电路和电动机电路中,作为电源开关、隔离开关、应急开关,并作为电路保护用,但一般不作为直接开闭单台电动机之用。

符合标准: GB14048.3、IEC60947-3。

HR6 fuse-switch disconnecter (hereinafter referred to as the switch) is mainly used in the distribution circuit with high short-circuit current and motor circuit where the rated voltage is AC 380V and 660V (45 to 62Hz), the conventional thermal current is up to 630A to serve as power switch, switch disconnecter, emergency switch and exert the function of circuit protection, but is generally not used to directly open and close a single motor.

Standard: IEC/EN 60947-3.

正常工作条件

Normal operating conditions

- 周围空气温度不高于+40℃, 不低于-5℃。
- 安装地点的海拔不超过2000m。
- 湿度: 最高温度为+40℃时, 空气的相对湿度不超过50%, 在较低的温度下可以允许有较高的相对湿度, 例如20℃时达90%。对于温度变化偶尔产生的凝露应采取特殊的措施。

- 周围环境的污染等级为3级。
- 开关应安装在无显著振动、冲击振动和没有雨雪侵袭的地方, 同时安装地点应无爆炸危险介质, 且介质中无足以腐蚀金属和破坏绝缘的气体及尘埃。

- Ambient temperature: -5℃~+40℃
- Altitude: 2000m;

- When the ambient air temperature is +40℃, the relative humidity of the air shall not be higher than 50%; a higher relative humidity is allowed at a lower temperature; for example, for the wettest month, the maximum relative humidity averaged shall be 90% while the lowest temperature averaged in that month +20℃, and special measures shall be taken for the condensation occasionally produced due to temperature change.
- Pollution degree: 3

- The ambient air is not significantly polluted by dust, smoke, corrosive and/or flammable gases, vapours or salt.

HR6 系列熔断器式隔离开关 Series fuse switch disconnecter

续表2 Continued Table 2

型号 Model	HR6-160	HR6-250	HR6-400	HR6-630
最大预期峰值电流(kA) Maximum expected peak current	100	100	100	100
配用NT熔断器尺码 Equipped with NT Fuse Size	00	1	2	3
污染等级 Pollution Level	3	3	3	3
安装类别 Installation category				

- 辅助开关额定电压交流380V, 约定发热电流5A, 使用类别为AC-1, 额定工作功率300VA。
Auxiliary switch rated voltage AC 380V, thermal current 5A, use category AC-1, rated operating power 300VA.

结构特征 Structure

- 开关由底座、盖和灭弧室等部分组成, 均由耐弧塑料制成, 为全塑型结构。静触头直接装在底座上, 灭弧室拆装方便, 每个灭弧室都有内室和外室二部份, 采用多片金属灭弧栅, 增强了灭弧能力, 提高了触头寿命。
- NT型熔断体装在盖的内部, 盖可沿支持件呈扇形旋转, 具有较大的电隔离距离以满足隔离开关的要求, 盖可以方便地从底座上拆下, 使得安装和更换熔断体很方便。底座上具有两组安装孔, 能满足各种开关柜内及面板上安装的要求。开关的两侧面, 根据需要可装辅助触头, 发出指示开关分合状态的信号。

- The switch is composed of base, cover, and arc quenching chamber and etc, all made of arc withstand plastic material. The static contacts are directly installed on the base, the arc quenching chamber is easy to be dismantled, each chamber has inner and outer parts, adopting multiple steel fence, arc quenching ability is increased, also improve the service life of contacts.
- NT type fuse link assembled in the cover, the cover can rotate around the support part, with large electric isolated distance, the cover can be dismantled easily from the base, so the fuse link can be easily installed and removed. On the base there have two groups of mounting holes, used to being fixed on different switchgear or panel. According to requirement, the two sides of switch can be assembled with auxiliary contacts for indicating the status of switch and etc.

外形及安装尺寸 Outline & installation size

- HR6系列开关外形及安装尺寸见图1, 表3 HR6 Dimensions (See Figure 1, Table 3)



图1 Figure 1

表3 Table 3

外形尺寸 Dimensions	规格 Specification		
	160A	250A	400-630A
A	215	280	300
B	134	184	244
C	200	260	280
D	80	120	160
E	40	60	60
F	40	60	80
G	110	160	186
H	240 max	310 max	350 max
A	7	9	9
B	7	9	9

订货须知 Ordering Information

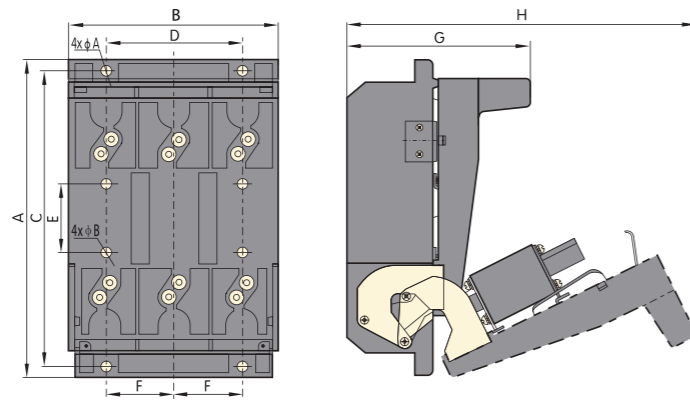
订货单位须注明开关的型式特征, 电压等级, 电流等级, 极数, 操作方式及数量等, 特殊订货请咨询我公司技术部门。HR6-400/30 660V熔断器电流315A, 10台。
Shall specify the type of feature order unit switches, voltage level, current level, very few, operating mode and quantity, special orders, please consult our technical department.
For example: HR6-400/30, 660V fuse current 315A, 10 units.

LW5D 万能转换开关 Universal Change-over Switch



适用范围 Application

LW5D系列万能转换开关主要适用于交流50~60Hz、电压至380V, 直流电压至440V的电路中转换电气控制线路(电磁线圈、电气测量仪表和伺服电动机等), 也可直接控制5.5kW三相笼型感应电动机(启动、可逆转换、变速)。
符合标准: GB 14048.5, IEC60947-5-1。

Electric ratings: AC50Hz, AC 500V/DC 440V;
Application: applied for change-over of circuit. In addition, it also can be used to directly control 5.5kW three-phase squirrel-cage motor;
Standard: IEC60947-5-1.

型号及含义 Type and meaning

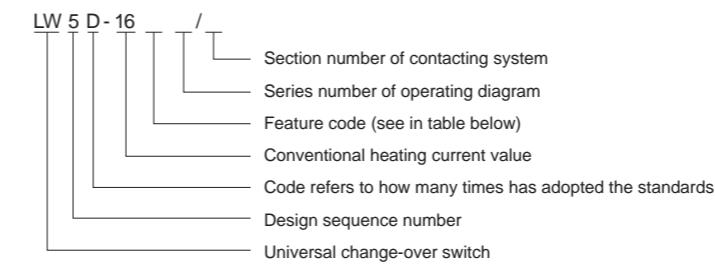
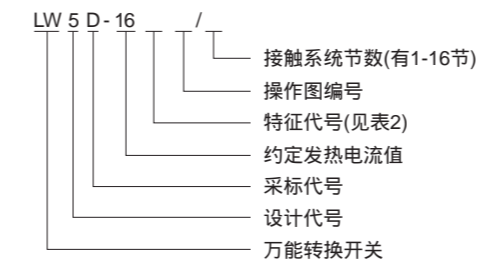

主要参数及技术性能 Main technical data

表1 Table 1

项目 Items	AC-15		DC-13		AC-15		AC-3		
	500	380	220	440	220	110	110	380	500
Ue(V)	500	380	220	440	220	110	110	380	500
Ie(A)	2.0	2.6	4.6	0.14	0.27	0.55	0.82	12	11
电寿命(次) Electric life	20×10 ⁴		20×10 ⁴				19.5×10 ⁴		
操作频率次/h Operating frequency (operations/h)	300								
机械寿命(次) Mechanical life	80×10 ⁴								
绝缘电压(V) Insulation voltage (V)	550V								
发热电流(A) Heating current (A)	16A								

LW5D

万能转换开关

Universal Change-over Switch



其它 Others

按操作方式与操动器位置组合分类 Classifications of operating mode and operating machine position combination

表2 Table 2

使用类别 Utilization classification	操作方式代号 Code of operating mode	操作手柄位置 Position of operating handle										节数 No. of sessions	备注 Note
自复型 Self-locking	A	0° ← 45°										1节	A: 电容器 辅柜2回路
	B	45° → 0° ← 45°											
	C	0° 45°											
	D	45° 0° 45°											
定位型 Orientation type	E	45° 0° 45° 90°										2节	B: 电容器 辅柜4回路
	F	90° 45° 0° 45° 90°											
	G	90° 45° 0° 45° 90° 135°											
	H	135° 90° 45° 0° 45° 90° 135°											
	I	135° 90° 45° 0° 45° 90° 135° 180°											
	J	120° 90° 60° 30° 0° 30° 60° 90° 120°											
	K	120° 90° 60° 30° 0° 30° 60° 90° 120° 150°											
	L	150° 120° 90° 60° 30° 0° 30° 60° 90° 120° 150°											
	M	150° 120° 90° 60° 30° 0° 30° 60° 90° 120° 150° 180°											
	N	45° 45°											
	P	90° 0° 90°											

分类

按用途分有主令控制用和直接控制5.5kW电动机用两种；
按操作方式分有定位型和自复型两种；
按接触系统节数分有1~16节，共16种。

分类

It can be classified into application for master control and direct control over 5.5kW motor according to purposes
Operating modes can be classified into orientation type and self-restoration type.
The Section number of contact system can be classified in to 16 kinds, which are from 1 to 16. Appearance of operation mechanism can be classified into rotary type and ball headed handle type.

电容器主柜有零位、自动、手动切换开关 Capacitor main cabinet has zero position, automatic, manual change-over switches

型号 Type	标号 Grade	自动 Automatic	停 Stop	手动 Manual	节数 No. of sessions
		45°	0°	45°	
LW5D-16 TD710/7	25-26	x			7节
	27-28	x			
LW5D-16 TD710/8	29-30	x			8节
	31-32	x			
LW5D-16 TD710/9	33-34	x			9节
	35-36	x			
LW5D-16 TD710/10	37-38	x			10节
	39-40	x			

电容器主柜有零位、自动、手动切换转换开关 Capacitor main cabinet has zero position, automatic, manual change-over switches

型号 Type	标号 Grade	A B C D E										节数 No. of sessions	备注 Note				
		自动	停	手动	2	3	4	5	6	7	8			9	10	11	12
特LW5D-16/3 TM703	1-2		x	x	x	x	x	x	x	x	x	x	x	x	x	1节	A: 电容器 主柜2回路
	3-4	x															
	5-6	x															
LW5D-16 TM704/4	7-8			x	x	x	x	x	x	x	x	x	x	x	2节	B: 电容器 主柜4回路	
	9-10				x	x	x	x	x	x	x	x	x	x			
LW5D-16 TM706/5	11-12					x	x	x	x	x	x	x	x	x	3节	C: 电容器 主柜6回路	
	13-14						x	x	x	x	x	x	x	x			
LW5D-16 TM706/6	15-16							x	x	x	x	x	x	x	4节	D: 电容器 主柜8回路	
	17-18								x	x	x	x	x	x			
LW5D-16 TM707/7	19-20									x	x	x	x	x	5节	E: 电容器 主柜10回路	
	21-22										x	x	x	x			
LW5D-16 TM712/8	23-24											x	x	x	6节	F: 电容器 主柜12回路	
	25-26												x	x			
LW5D-16 TM712/8	27-28													x	7节		
	29-30													x			
LW5D-16 TM712/8	31-32													x	8节		
														x			

电容器辅助转换开关
Capacitor and auxiliary switch cabinet

型号 Type	标号 Grade	A B C D E										节数 No. of sessions	备注 Note	
		0°	30°	60°	90°	120°	150°	180°	210°	240°	270°			300°
LW5D-16TM601/1	1-2		x	x	x	x	x	x	x	x	x	x	1节	A: 电容器 辅柜2回路
	3-4			x	x	x	x	x	x	x	x	x		
LW5D-16TM602/2	5-6				x	x	x	x	x	x	x	x	2节	B: 电容器 辅柜4回路
	7-8					x	x	x	x	x	x	x		
LW5D-16TM603/3	9-10						x	x	x	x	x	x	3节	C: 电容器 辅柜6回路
	11-12							x	x	x	x	x		
LW5D-16TM604/4	13-14								x	x	x	x	4节	D: 电容器 辅柜8回路
	15-16									x	x	x		
LW5D-16TM605/5	17-18										x	x	5节	E: 电容器 辅柜10回路
	19-20											x		

外形及安装尺寸 Outline & installation size

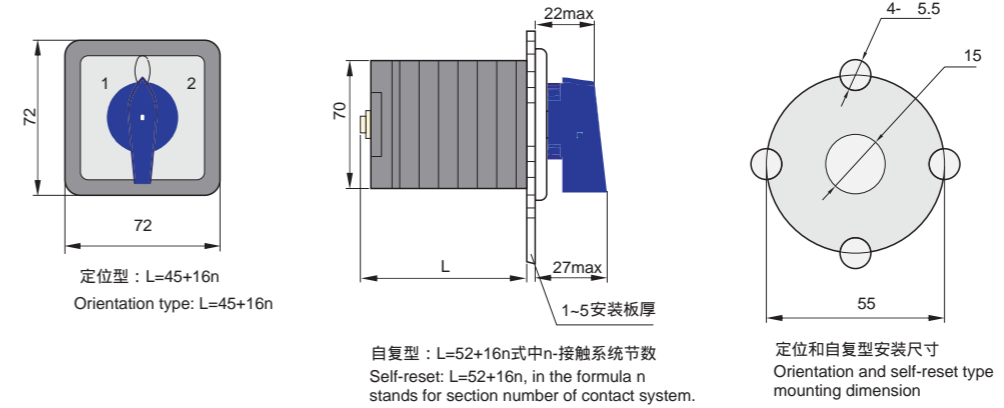

订货须知 Ordering Information

用户订货时，采用开关的完整型号进行订货。

例如：订货万能转换开关LW5D，

接线图型式为右图；

订货代号为LW5D-16 D0723/3 100台。

When a user orders using the switch complete model were orders.

For example: Ordering universal switch LW5D,

Wiring diagram type is right;

Ordering code for LW5D-16 D0723 / 3 100 units.

接线图编号 No.	D0723		
转换角度 Angle	45°	0°	45°
1-2	x		
3-4			x
5-6	x		
7-8			x
9-10	x		
11-12			x

LW12

万能转换开关

Universal Change-over Switch



型号及含义 Type and meaning

● 主令控制用型号 Type applied for master control

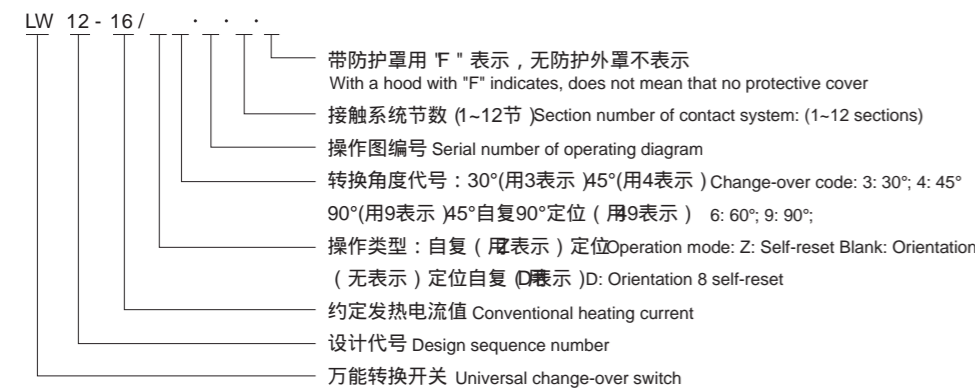

主要参数及技术性能 Main technical data

表1 Table 1

项目 Items	AC-15	DC-13	AC-13	AC-4
工作电压(V) Operational voltage (V)	380	220	380	380
工作电流(A) Operational current (A)	2.6	0.6	12	12
绝缘电压(V) Insulation voltage (V)	550	550		
发热电流(A) Heating current (A)	16			
电寿命(次) Electric life (operations)	20×10 ⁴	20×10 ⁴	19.5×10 ⁴	0.5×10 ⁴
机械寿命(次) Mechanical life (operations)	80×10 ⁴			
操作频率(次/h) Operating frequency (operations/h)	300次/h(当AC-4时120次/h)			
	300 operations/h (Under the condition of AC-4, the value is 120 operations/h)			

订货须知 Ordering Information

用户订货时, 采用开关的完整型号进行订货。

例如: 订货万能转换开关LW12,

接线图型式为右图;

订货代号为LW12-16/4.0408.2 10台。

When a user orders using the switch complete model were orders.

For example: Ordering universal switch LW12,

Wiring diagram type is right;

Ordering code for LW12-16/4.0408.2 10 units.

接线图编号 No.	4.0408		
转换角度 Angle	45°	0°	45°
1-2	×		×
3-4	×		×
5-6	×		×
7-8	×		×

适用范围 Application

LW12万能转换开关主要适用于交流50~60Hz、电压380V及以下, 直流电压220V及以下的电路中转换电气控制线路和电气测量仪表。也可直接控制5.5kW及以下的三相交流笼型感应电动机。主要用于仪表, 微电机, 电磁阀等控制线路中。符合标准: GB 14048.5, IEC60947-5-1。

Electric ratings: AC50Hz, AC 380V/DC 220V;
Application: applied for change-over of circuits under various conditions; In addition, it also can be applied to control three-phase squirrel-cage motor with small capacity;
Standard: IEC60947-5-1.

外形及安装尺寸

Outline & installation size

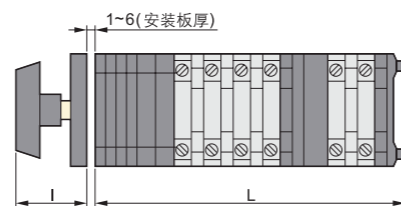

L=31+13.5n(定位型),
L=43+13.5n(自复型、定位自复型)
L=58+13.5n(带45°自由行程触头的定位自复型),
l=33~46

L=31+13.5n (Orientation type)
L=43+13.5n (self-reset type, orientation self reset type)
L=58+13.2 (Orientation self reset type with free travel contact), l=33~46

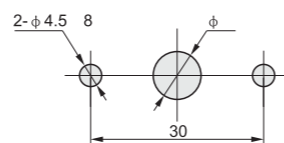
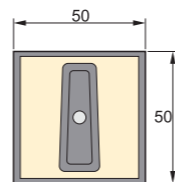

QZB

系列自耦变压器

Series autotransformer



主要功能及特点 Main functions and features

自耦变压器是一种单圈式变压器, 一、二侧共用一绕组绕制, 其电压比是固定的。自耦变压器与同容量的一般变压器相比较, 具有结构简单、用料省、体积小等优点, 尤其在电压比接近1的场合显得特别经济, 所以在电压相近的大功率输电变压器中用得较多, 此外在10千瓦以上异步鼠笼型电动机降压启动柜中得到广泛使用。

This autotransformer is a kind of single-turn transformer, the primary and secondary sides use the same winding, and the voltage ratio is fixed. When comparing with the general transformers of the same capacity, this autotransformer has advantages of simplified structure, less material, smaller volume, etc., especially shows its economical efficiency when the voltage ratio is about 1. It is widely applied to the high power transmission transformers with similar voltage, besides, it is applicable to voltage-reduced starting cabinet of asynchronous squirrel cage motor of 10KW above.

适用范围 Application

本启动自耦变压器系用于三相交流50Hz/380V, 功率14-300kW鼠笼型电动机自耦降压启动, 启动完毕将变压器切除。

This starting autotransformer is applicable to three-phase squirrel cage motor of AC50Hz/380V with power 14-300kW for auto-induction voltage-reduced starting, when the starting is finished, the transformer will be cut off.

外形及安装尺寸

Outline & installation size

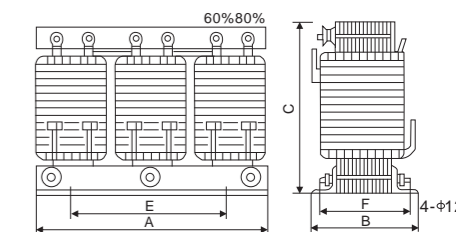

主要技术参数 Main Technical data

型号 Type	自耦变压器功率 Power of Autotransformer (KW)	控制电动机功率 Power of control motor (KW)	额定工作电流参考值 Reference value of rated working current (A)	最大启动时间 Max starting time (S)	外形尺寸 Overall Dimension cm		
					A	B	C
QZB-14	14	14	26	30	31	12	25
QZB-17	17	17	32	30	31	13	25
QZB-22	22	22	42	40	31	14	25
QZB-30	30	30	57	40	31	15	25
QZB-40	40	40	76	40	34	16	26.5
QZB-55	55	55	103	40	37	16	28
QZB-75	75	75	140	40	37	17	29
QZB-100	100	100	182	60	39	20	31
QZB-115	115	115	207	60	39	21	31
QZB-135	135	135	248	60	43	20	35
QZB-160	160	160	286	60	43	21	35
QZB-190	190	190	331	60	49	25	40
QZB-225	225	225	404	60	49	25	40
QZB-226	260	260	459	60	58	27	46
QZB-300	300	300	514	60	58	27	46

JJ1(XJ01), JJ1B

系列自耦减压起动柜

Series self-coupling decompression starting cabinet



主要功能及特点 Main functions and features

利用自耦变压器的降压功能，降低电动机的起动电流，将电动机加速接近额定转速，保证电动机的正常运行，且可减少电动机起动电流对输电网络的影响。线路中具有过载、欠电压和断相保护，且可人为的分断电动机的电源，是XJ01系列起动箱的理想替代产品。

It makes use of voltage-reducing function of auto-transformer, steps down the starting current of electric motor, let the acceleration of motor close to the rated rotary speed, guaranteeing normal running of motor, and reduces effect of starting current to the transmission network. The circuitry has protection functions against overload, under-voltage or open-phase, it also is able to cut off the power supply of motor by manual, it really is the ideal substitute product instead of XJ01 series starting box.

主要技术参数 Main Technical data

型号 Type	控制电动机功率 Power of control motor(KW)	最大工作电流 Max working current(A)	电流互感器变比 Transformation ratio of current transformer (A)	保护器整定电流参考值 Reference value for setting current of protector (A)	外形尺寸(CM) Overall Dimension		
					A	B	C
JJ1 -17	17	33	50/5	33	40	26	70
JJ1 -22	22	40	75/5	40	40	26	70
JJ1 -30	30	57	75/5	57	40	26	70
JJ1 -40	40	75	100/5	75	46	31	90
JJ1 -45	45	83	100/5	83	46	31	90
JJ1 -55	55	101	200/5	101	46	31	90
JJ1 -75	75	137	200/5	137	46	31	90
JJ1 -100	100	185	300/5	3.1	55	42	126
JJ1 -115	115	211	300/5	3.5	55	42	126
JJ1 -135	135	247	400/5	3.1	55	42	126
JJ1 -160	160	293	400/5	3.7	55	42	126
JJ1 -190	190	348	400/5	4.4	60	47	140
JJ1 -225	225	412	600/5	3.4	60	47	140
JJ1 -260	260	476	600/5	4.0	70	59	170
JJ1 -300	300	549	600/5	4.6	70	59	170
JJ1 -320	320	585	600/5	1.9	70	59	170
JJ1 -350	350	640	800/5	4.0	70	59	170
JJ1 -400	400	730	800/5	4.6	根据用户技术要求制造。 According to the technical requirements for manufacturing customers.		
JJ1 -450	450	825	1000/5	4.1			
JJ1 -500	500	914	1000/5	4.6			
JJ1 -600	600	1097	1500/5	3.7			

适用范围 Application

JJ1(XJ01)、JJ1B系列自耦减压起动柜适用于三相交流50Hz/380V，功率600kW及以下鼠笼型电动机自耦降压起动、运行及停止控制。

JJ1(XJ01) and JJ1B series self-coupling decompression starting cabinet is suitable for three-phase squirrel cage motor of AC50Hz/380V with power up to and including 600kW, used for self-coupling decompression starting, running and stopping control.

外形及安装尺寸 Outline & installation size

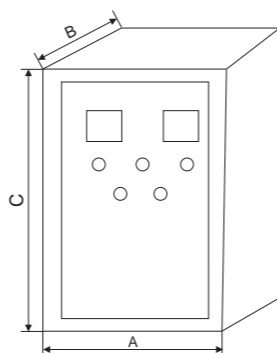

QX4

系列星三角起动柜

Series star-delta starting cabinet



适用范围 Application

QX4系列星三角起动柜适用于三相交流50Hz/380V,功率135KW以下的三相鼠笼型电动机，用于控制电动机定子绕组由“星形”至“三角形”的换接起动，运行及停止，可实现对电动机的过载和断相等保护。

QX4 series star-delta starting cabinet is applicable to three-phase squirrel cage motor of AC50Hz/380V with power up to 135KW, used for controlling the starting, running and stopping of switching from "star" to "delta" of motor stator winding, protects the motor against overload or open-phase.

主要功能及特点 Main functions and features

当起动柜起动电动机时，使每相定子绕组所受的电压在起动时降低到电路中的电压的57.7%，其电流为直接起动时的1/3，而起动转矩也同时减小到直接起动的1/3。起动柜的工作制为间断长期工作制或反复短时工作制，反复短时工作下的操作频率为每小时30次，连续操作起动的间隔时间为90秒。

When the starting cabinet starts up the motor, the voltage being applied to stator winding of each phase is reduced to 57.7% of voltage in circuit, and the current is 1/3 of direct starting value, meanwhile, the starting torque is reduced to 1/3 of direct starting value. Working system of starting cabinet is interrupted continuous duty system or repetitious short-time duty system, operating frequency under repetitious short-time duty system is 30 times per hour, interval time of interrupted continuous duty system is 90s.

主要技术参数 Main Technical data

型号 Type	自耦变压器功率 Power of Autotransformer (KW)	控制电动机功率 Power of control motor (KW)	额定工作电流参考值 Reference value of rated working current (A)	最大起动时间 Max starting time(S)	外形尺寸(CM) Overall Dimension		
					A	B	C
QX4-13	13	28	16	11	40	26	70
QX417	17	33	19	13	40	26	70
QX4-22	22	43	25	15	40	26	70
QX4-30	30	60	35	16	40	26	70
QX4-40	40	78	45	20	40	26	70
QX4-55	55	104	60	24	40	26	70
QX4-75	75	142	85	30	40	26	70
QX4-115	115	230	135	30	46	31	90
QX4-135	135	270	160	35	55	42	126

外形及安装尺寸 Outline & installation size

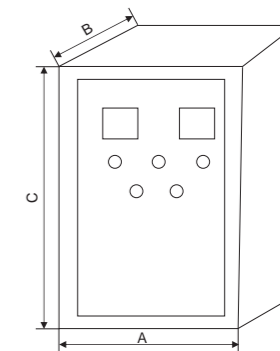

XQP

系列频敏起动柜

Series frequency-sensitive starting cabinet



主要功能及特点 Main functions and features

起动柜起动过程是在转子回路中接有频敏变阻器，其阻抗值随电动机转速的增加而降低，起动时阻抗较大，从而达到限制起动电流作用，起动柜具有短路、断相和过载保护。

Starting process of starting cabinet is a process of connecting frequency-sensitive rheostat in the rotor circuit, its impedance value is reduced along with increase of motor's rotary speed. The impedance is larger during starting, this property limits the starting current. This starting cabinet has protection functions against short-circuit, open-phase or overload.

主要技术参数 Main Technical data

型号 Type	被控制的电动机 The controlled motor		动力回路×接 触器容量(A) Power circuit × capacity of contactor (A)	电流互感器变比 Transformation ratio of current transformer	热继电器 整定值(A) Setting value of thermal relay (A)	外形尺寸 Overall Dimension		
	功率 Power (KW)	定子电流 Stator current (A)				A	B	C
XQP - 14~40	14~17	20~35	1×100(定子)+ 1×100(转子)	50/5	20~35	60	40	100
	20~22	40~45			40~45	60	40	100
	23~30	55~60		75/5	55~60	60	40	100
XQP - 45~60	40	80~85	1×160(定子)+ 1×160(转子)	100/5	90	60	40	100
	55~60	108~121		200/5	108~121	60	40	100
XQP - 65~115	65~75	140~150	1×250(定子)+ 1×250(转子)	300/5	140~150	65	45	120
	80	158~160			2.6	65	45	120
	95~100	182~197		3.0~3.3	65	45	120	
XQP - 130~185	110~115	211~238	1×400(定子)+ 1×400(转子)	400/5	3.5~4.0	65	45	120
	130~135	246~267			3.0~3.3	65	50	140
	155	288~304			3.6~3.8	65	50	140
XQP - 210~300	180~185	327~350	1×630(定子)+ 1×630(转子)	600/5	4.0~4.3	65	50	140
	210~225	399~405			3.3	80	55	180
	240	436			3.6	80	55	180
	245~260	466			3.9	80	55	180
	280	510			4.3	80	55	180
	300	535			4.5	80	55	180

适用范围 Application

XQP系列起动柜适用于三相交流50HZ/380V，功率300KW以下的三相绕线型电动机的起动、运行及停止控制。也可用于不频繁操作、不可逆、不调速和不要求制动的场所。

XQP series starting cabinet is applicable to three-phase wound motor of AC 50HZ/380V with power up to 300KW, for starting, running and stopping control. It also can be used for occasions where require infrequent and irreversible operation, and no speed regulation or braking.

外形及安装尺寸 Outline & installation size

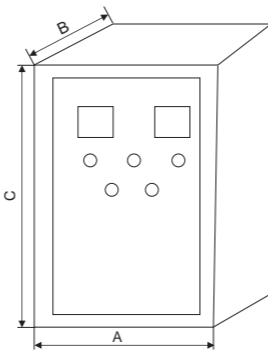

ZMR8

电机软起动器

Motor soft starters



适用范围 Application

智能化数字式电机软起动器，采用智能化数字式控制；以单片机为智能中心，可控硅模块为执行元件对电动机进行全自动控制。它适用各种负载的鼠笼型异步电动机控制，使电动机在任何工作状况下均能平滑起动，保护拖动系统，减少起动电流对电网冲击，保证电动机可靠起动。平滑减速停车软停车功能有效地解决了惯性系统的停车喘振问题，消除拖动系统的反惯性冲击，是传统设备无法实现的。智能化数字式电机软起动器具有完整的系统保护功能，延长系统的使用寿命、降低系统造成本、提高系统的可靠性且兼容了所有起动设备的各种功能；是传统星三角起动、自耦减压起动等最理想的新替代产品。

Intelligent digital soft starter for motor adopts digital control, based on MCU, choose the controllable silicon module as execution element, and perform full auto control on the motor. It is suitable for the various squirrel-caged asynchronous motors, make the motor able to start smoothly at any working status, protect the driving system, reduce the surge of the starting current on system, and ensure the motor reliably being started. The function of softly and smoothly stopping the motor can effectively solve the surging shock due to inertia, eliminate the inverse inertia impact of the driving system, which can't be solved by traditional starters. Digital soft starter has complete protection functions, extend the servicing life of the system, reduce the cost for constructing the system, improve the reliability, absorb the various functions from all starting devices: it is the ideal substitute for the old star-delta starter, self-coupled voltage reduction starter and etc.

产品特点 Features

可靠的质量保证：

- 采用计算机模拟设计；
- SMT贴片生产工艺；
- 优异的电磁兼容性能；
- 整机出厂前的高温老化，振动试验。

完善可靠的系统保护功能：

- 失压、欠压、过压保护；
- 软起动器过热、起动时间过长保护；
- 输入缺相、输出缺相、三相不平衡保护；
- 起动过流、运行过载、负载短路保护。

维护功能：

- 故障自诊断（短路，过电压，欠压，单相接地，电机过载，断相，堵转，加上智能程序可研判拖动系统工作状态）；
- 模块化组合设计、根据故障显示内容、快速排除故障。

自主知识产权的产品：

- 专有的电机起动和保护技术；
- 独有的检测调试设备和工艺。
- 迅速周到的售后服务；
- 可靠的性能和质量奠定优质服务的基础；
- 提供优秀完善的配套设计方案；
- 及时周到的使用咨询；
- 根据用户意见不断提高产品性能。

主要参数及技术性能 Main technical data

- 使用类别：AC-53b
- 设计型式：2
- 额定工作电压：AC380V
- 额定绝缘电压：AC660V
- 额定频率：50Hz
- 额定冲击耐受电压：4kV
- 额定限制短路电流：19kA(ZMR8-5.5-75)
23 kA(ZMR8-75-320)
- SCPD配合类型：1
- 外壳防护等级：IP20

Reliable quality guaranteed:

- Designed by computer simulation;
- SMT surface mounting technology used;
- Excellent electromagnetic compatibility;
- The product has performed the test of hi-temperature aging and shock

Complete and reliable protection functions:

- Voltage lost, under-voltage, over-voltage protected;
- Protection against the starter overheating, or too long starting time.
- Protection against input phase failure, output phase failure, three phase imbalance;
- Protection against starting over-current, operating overloading, and loading short circuit fault .

Maintenance function:

- Fault self-diagnosed (Short circuit, over-voltage, under-voltage, single phase earthed, motor overloaded, phase failure, rotation blocked, if cooperated with intelligent program it can identify the working status of driving system)
- Module combination, quickly solve the fault according displayed content

The product with self intellectual property:

- Special motor starting and protection technology;
- Peculiar inspection and commission equipment and technology.
- Fast and complete after-sales services;
- Reliable performances and quality is the base for excellent services;
- Provide the excellent and complete design plan;
- Punctual and complete operation consults;
- Continue improving the product according to user comments

- Use category: AC-53b

- Design Type: 2
- Rated working voltage: AC380V
- Rated insulation voltage: AC660V
- Rated frequency: 50Hz
- Rated impulse withstand voltage: 4kV
- Rated limit short-circuit current: 19kA (ZMR8-5.5-75)
23 kA (ZMR8-75-320)

- SCPD with type: 1
- Shell protection grade: IP20

型号及其含义 Code and implication

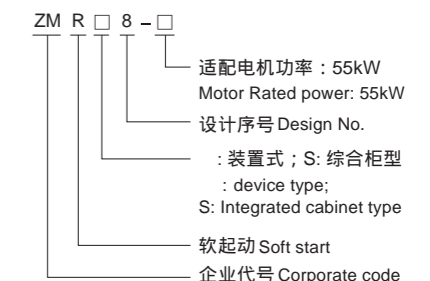

ZMR8

电机软起动器

Motor soft starters

正常工作条件 Normal operating conditions

- 供电电源：市电、自备电站、柴油发电机组三相交流电，可根据产品制作额定电压110V-1140V±20%、50Hz或60Hz，电源容量必须满足软起动柜对电动机的起动要求。
- 适用电机：鼠笼式三相异步电动机，电机额定功率应与软起动柜额定功率相符或以下。
- 起动频度：没有要求，具体次数视负载情况而定。
- 冷却方式：强迫风冷。
- 防护等级：IP20
- 环境条件：海拔3000米以下，环境温度-20 ~ +40 之间，相对湿度95% RH以下，无凝露，无易燃、易爆、易腐蚀性气体，无导电性尘埃，室内通风良好、震动小于0.5G的地方。
- 本公司可为用户提供在特殊条件下使用的产品，如防爆型、低温型、高压型软起动器，其使用条件另行说明。

- **Power supply:** three phase AC power from system, self-prepared substation, diesel generator, also we can make the starter with rated voltage 110V-1140V±20%、50Hz or 60Hz according to demand, the capacity of power supply must meet with the requirement of starting motor.
- **Applicable motor:** three phase squirrel cage asynchronous motor, rated power of motor must not exceed the rated power of soft starter.
- **Startup freq:** not requested, determine according to the loading status.
- **Cooling mode:** forcedly wind cooling
- **Protective grade:** IP20
- **Ambient conditions:** altitude less than 3000m, ambient temperature: -20°C+40°C, relative humidity less than 95%, the working site shall have no dew, no flammable, explosive, corrosive gas, no conductive dust, well ventilated indoor, shake less than 0.5g.

外形及安装尺寸

Outline & installation size

● 适用电机5.5KW~75KW外形尺寸图 Dimensions for 5.5KW~75KW

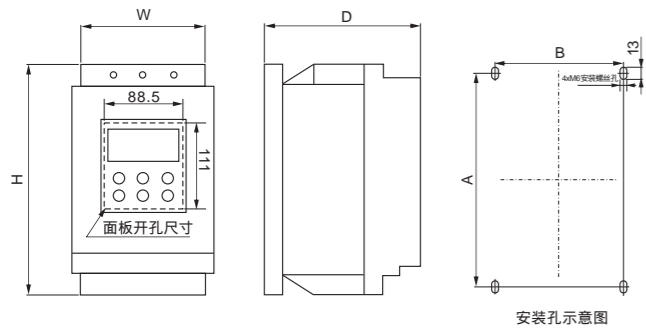

软起动器型号规格 Model	额定功率 Rated power (KW)	额定电流 Rated current (A)	外形尺寸(mm) Dimensions			安装尺寸(mm) Mounting dimensions		净重(kg) Weight	
			H	W	D	A	B		安装螺丝孔
ZMR8-5.5	5.5	11	272	146	160	251	132	M6	<4.8
ZMR8-7.5	7.5	15	272	146	160	251	132	M6	<4.8
ZMR8-11	11	22	272	146	160	251	132	M6	<4.8
ZMR8-15	15	30	272	146	160	251	132	M6	<4.8
ZMR8-18.5	18.5	37	272	146	160	251	132	M6	<4.8
ZMR8-22	22	44	272	146	160	251	132	M6	<4.8
ZMR8-30	30	60	272	146	160	251	132	M6	<4.8
ZMR8-37	37	74	272	146	160	251	132	M6	<4.8
ZMR8-45	45	90	272	146	160	251	132	M6	<4.8
ZMR8-55	55	110	272	146	160	251	132	M6	<4.8
ZMR8-75	75	150	272	146	160	251	132	M6	<4.8

● 适用电机75KW~600KW外形尺寸图 Dimensions for 75KW~600KW

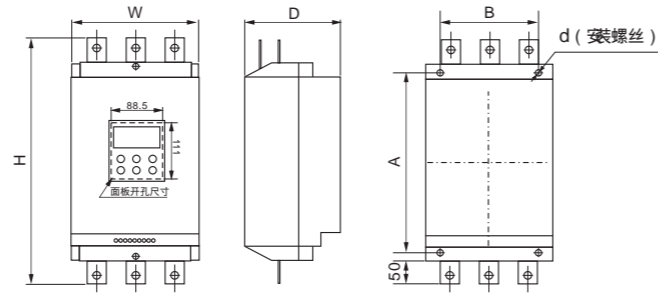

软起动器型号规格 Model	额定功率 Rated power (KW)	额定电流 Rated current (A)	外形尺寸(mm) Dimensions			安装尺寸(mm) Mounting dimensions		净重(kg) Weight	
			H	W	D	A	B		安装螺丝孔
ZMR8-75	75	150	530	260	195	380	195	M8	<20
ZMR8-90	90	180	530	260	195	380	195	M8	<20
ZMR8-115	115	230	530	260	195	380	195	M8	<20
ZMR8-132	132	264	530	260	195	380	195	M8	<20
ZMR8-160	160	320	530	260	195	380	195	M8	<20
ZMR8-185	185	370	530	260	195	380	195	M8	<20
ZMR8-200	200	400	530	260	195	380	195	M8	<20
ZMR8-250	250	500	530	260	195	380	195	M8	<20
ZMR8-280	280	560	530	260	195	380	195	M8	<20
ZMR8-320	320	640	560	290	245	460	260	M8	<23
ZMR8-400	400	800	590	330	245	500	270	M8	<31
ZMR8-450	450	900	590	330	245	500	270	M8	<31
ZMR8-500	500	1000	590	330	245	500	270	M8	<33
ZMR8-600	600	1200	660	410	245	550	370	M8	<35

接线图 Wiring Diagram

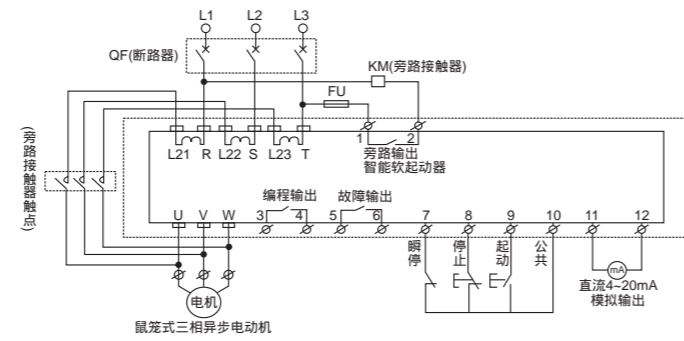

注：此图为基础型

- 1、2接点是控制旁路接触器的接点是无源继电器输出点；7接点断开为瞬停输入，一般应用在故障瞬停；8接点断开为软停；9接点通为软起；10接点为公共端；3、4接点为可编程继电器接点可与软起同步延时；
- 软起动器内置短路保护和过载保护；7接点瞬停自复位可编程；控制模式限流型和电压斜坡型，任意自选；11、12为0-20mA模拟信号输出；

Note: it is basic type in this picture

- 1, 2 connection points are the non-voltage relay output to control bypass contactor, point 7 being opened is the input of immediate stop, this is used in the case of immediate stopping under fault; point 8 being opened is soft stopping; point 9 being closed is used for soft starting, point 10 is public terminal, point 3, 4 are for programmable relay connection, able to delay synchronously with soft starting.

The short circuit and overloading protection built in soft starter: point 7 is immediate stopping and auto reset, programmable; control mode: current limiting mode and voltage sloping wave type, selected freely; point 11, 12 is the output of analog signal 0-20mA.

ZMR8-G

电机软起动器 / 在线式智能电机软起动柜

Motor soft starters/Intelligent Motor soft start cabinet



正常工作条件 Normal operating conditions

- 供电电源：市电、自备电站、柴油发电机组三相交流电，可根据产品制作额定电压110V-1140V±20%、50Hz或60Hz，电源容量必须满足软起动柜对电动机的起动要求。
- 适用电机：鼠笼式三相异步电动机，电机额定功率应与软起动柜额定功率相符或以下。
- 起动频度：没有要求，具体次数视负载情况而定。
- 冷却方式：强迫风冷。
- 防护等级：IP20
- 环境条件：海拔4000米以下，环境温度-20 ~ +40 之间，相对湿度95% RH以下，无凝露，无易燃、易爆、易腐蚀性气体，无导电性尘埃，室内通风良好、震动小于0.5G的地方。

主要参数及技术性能 Main technical data

型号规格 Model	额定功率 Rated power	最大工作电流 Max.operating current	外形尺寸(mm) Dimensions			重量(kg) Weight
			A	B	C	
ZMR8-5.5-G	5.5	11	700	350	250	<20
ZMR8-7.5-G	7.5	15				
ZMR8-11-G	11	22				
ZMR8-15-G	15	30				
ZMR8-18.5-G	18.5	37	900	370	310	<33
ZMR8-22-G	22	44				
ZMR8-30-G	30	60				
ZMR8-37-G	37	74				
ZMR8-45-G	45	90	1100	500	320	<48
ZMR8-55-G	55	110				
ZMR8-75-G	75	150				
ZMR8-90-G	90	180				
ZMR8-115-G	115	230	1250	600	370	<63
ZMR8-132-G	132	264				
ZMR8-160-G	160	320				
ZMR8-185-G	185	370				
ZMR8-200-G	200	400	1350	650	380	<76
ZMR8-250-G	250	500				
ZMR8-280-G	280	560				
ZMR8-320-G	320	640				
ZMR8-400-G	400	800	1570	700	440	<103
ZMR8-450-G	450	900				
ZMR8-500-G	500	1000				
ZMR8-600-G	600	1200				

适用范围 Application

在线式智能化电机软起动柜，采用智能化数字式控制；以单片机为智能中心，可控硅模块为执行元件对电动机进行全自动控制。它适用各种负载的鼠笼型异步电动机控制，使电动机在任何工作状况下均能平滑起动，保护拖动系统，减少起动电流对电网冲击，运转保证电动机可靠起动。平滑减速停车软停车功能有效地解决了惯性系统的停车喘振问题，消除拖动系统的反馈性冲击，是传统设备无法实现的。智能化数字式电机软起动器具有完整的系统保护功能，延长系统的使用寿命、降低系统造价成本、提高系统的可靠性且兼容了所有起动设备的各种功能；是传统星三角起动、自耦减压起动等最理想的替代产品。

Online intelligent soft starter for motor adopts digital control, based on MCU, choose the controllable silicon module as execution element, and perform full auto control on the motor. It is suitable for the various squirrel-caged asynchronous motors, make the motor able to start smoothly at any working status, protect the driving system, reduce the surge of the starting current on system, and ensure the motor reliably being started. The function of softly and smoothly stopping the motor can effectively solve the surging shock due to inertia, eliminate the inverse inertia impact of the driving system, which can't be solved by traditional starters. Digital soft starter has complete protection functions, extend the servicing life of the system, reduce the cost for constructing the system, improve the reliability, absorb the various functions from all starting devices: it is the ideal substitute for the old star-delta starter, self-coupled voltage reduction starter and etc.

型号及其含义 Code and implication

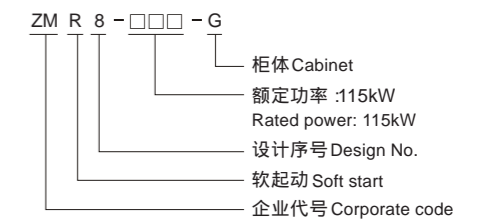

外形及安装尺寸

Outline & installation size

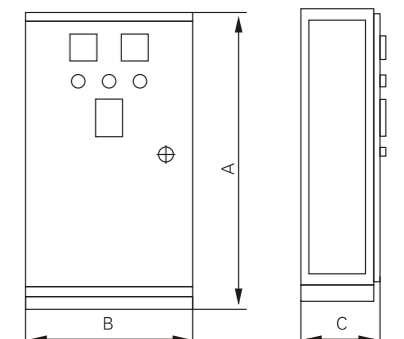

HY/Y 系列金属氧化锌避雷器 Series ZnO Surge Arrester

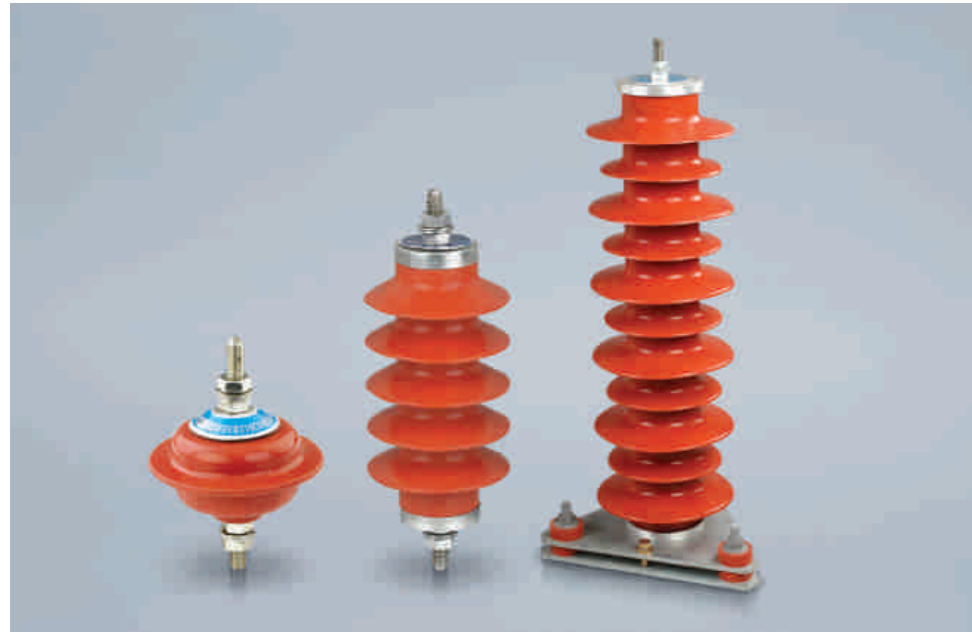

型号及含义 Type and meaning

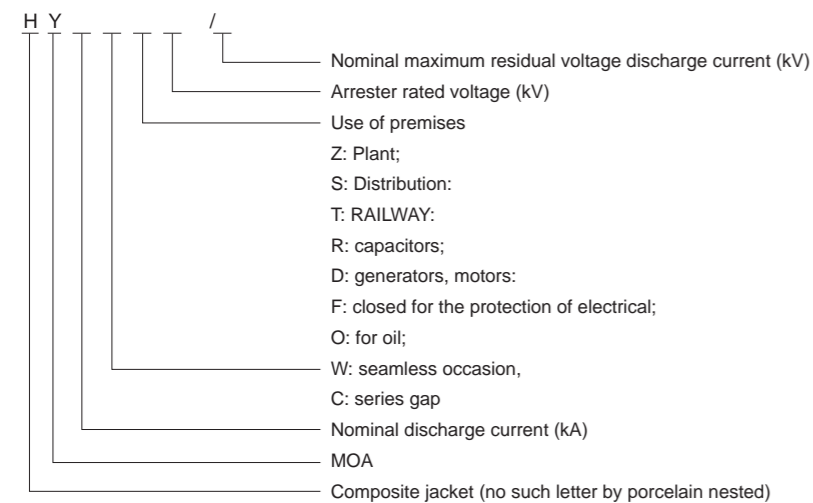
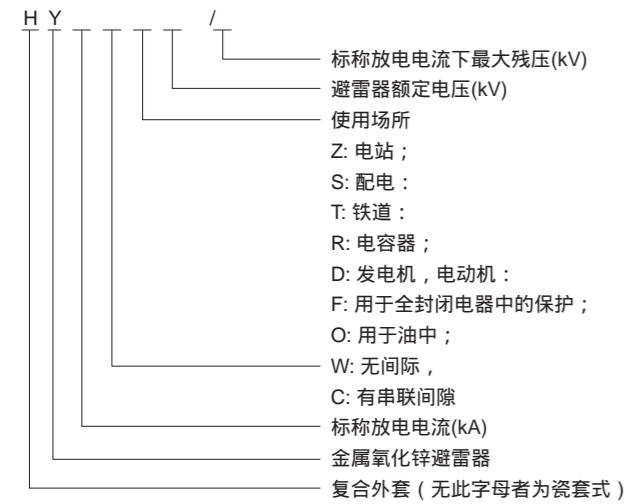

适用范围 Application

金属氧化锌避雷器是目前国际上最先进的过电压保护设备,适用于交流频率48~62Hz, 35KV及以下交流电力系统用限制过电压的避雷器,用于保护电力系统各种电气设备的绝缘免受雷电过电压或操作过电压的损害,是保证电力系统安全运行的重要保护设备之一。

其特点是:金属氧化锌避雷器采用伏安特性优异的氧化锌电阻片作为芯体,与传统的碳化硅避雷器相比,具有动作迅速、陡波特性好、残压低、通流容量大、无续流、结构简单、重量轻、可靠性高、耐污秽能力强、维修简便等优点。复合外套型还具有外套采用硅橡胶整体模压成型,无气隙,密封性能好,防潮防爆,无炸裂危险,特别适宜开关柜使用。

本产品主要技术性能符合GB11032-2000及JB/T8952-1999标准规定。

ZnO arrester is the latest over-voltage protective device, suitable for AC 48~62Hz, 35KV and below power system to limit the over voltage, protect the insulation of electric equipment from being destroyed by lightning voltage or switching over-voltage, it is one of important device to protect power system and ensure the safety of operation. Its features: the arrester adopts ZnO varistors with excellent volt-amps curves, compared with old arresters, its advantages cover fast response, good steep wave, low residual voltage, large square-wave current, no continuous current, simple structure, light weight, high reliability, anti-pollution, easy maintenance and etc. Polymer type made of silicone rubber housing, no gap, good sealing performance, moisture resistant explosion proof, no risk of crack, especially suitable for assembly in the switchgear.

These products comply with the standard of GB11032-2000 and JB/T8952-1999

主要参数及技术性能 Main technical data

使用场所 Use of premises	产品型号 Type	避雷器额定电压 kV(有效值) Rated voltage of arrester (RMS)	系统额定电压kV(有效值) System Rated voltage (RMS)	持续运行电压kV(有效值) Continuous operating voltage (RMS)	直流1mA参考电压 ()kV DC (1mA) reference voltage	雷电冲击残压 (kV) Under lightning impulse current	陡波冲击残压 (kV) Under steep impulse current	操作冲击残压 (kV) Under operating impulse current	2ms μ s方波冲击电流A(峰值) 2ms μ s Rectangular current (peak)
电站 Transformer substation	HY5WZ-3.8/13.5	3.8	3.0	2.0	7.2	13.5	15.5	11.5	200
	HY5WZ-5/13.5	5.0	3.0	4.0	7.2	13.5	15.5	11.5	200
	HY5WZ-7.6/27	7.6	6.0	4.0	14.4	27.0	31.0	23.0	200
	HY5WZ-10/27	10.0	6.0	8.0	14.4	27.0	31.0	23.0	200
	HY5WZ-12/32.4	12.0		9.6	17.4	32.4	37.2	27.6	200
	HY5WZ-15/40.5	15.0		12.0	21.8	40.5	46.5	34.5	200
	HY5WZ-12.7/45	12.7	10.0	6.6	24.0	45.0	51.8	38.3	200
	HY5WZ-17/45	17.0	10.0	13.6	24.0	45.0	51.8	38.3	200
配电及线路 Distribution and Power Line	HY5WS-42/134	42.0	35.0	23.4	73.0	134.0	154.0	114.0	400
	HY5WS-51/134	51.0	35.0	40.8	73.0	134.0	154.0	114.0	150
	HY5WS-3.8/17	3.8	3.0	2.0	7.5	17.0	19.6	14.5	150
	HY5WS-5/15	5.0	3.0	4.0	7.5	15.0	17.3	12.8	150
	HY5WS-7.6/30	7.6	6.0	4.0	15.0	30.0	34.5	25.5	150
	HY5WS-10/30	10.0	6.0	8.0	15.0	30.0	34.6	25.6	150
	HY5WS-12/35.8	12.0		9.6	18.0	35.8	41.2	30.6	150
	HY5WS-15/45.6	15.0		12.0	23.0	45.6	52.5	39.0	150
电容器用 Capacitors	HY5WS-12.7/50	12.7	10.0	6.6	25.0	50.0	57.5	42.5	150
	HY5WS-17/50	17.0	10.0	13.6	25.0	50.0	57.5	42.5	150
	HY5WR-3.8/13.5	3.8	3.0	2.0	6.9	13.5		10.5	400
	HY5WR-5/13.5	5.0	3.0	4.0	7.2	13.5		10.5	400
	HY5WR-7.6/27	7.5	6.0	4.0	13.8	27.0		20.8	400
	HY5WR-10/27	10.0	6.0	8.0	14.4	27.0		21.0	400
	HY5WR-12.7/45	12.7	10.0	6.6	23.0	45.0		35.0	400
	HY5WR-17/45	17.0	10.0	13.6	24.0	46.0		35.0	400
电机专用 Motor special	HY5WR-42/134	42.0	35.0	23.4	70.0	134.0		105.0	400
	HY5WR-51/134	51.0	35.0	40.8	73.0	134.0		105.0	400
	HY2.5WD-3.8/9.5	3.8	3.15	2.0	5.6	9.5	10.9	7.6	200
	HY2.5WD-4/9.5	4.0	3.15	3.2	5.7	9.5	10.7	7.6	200
	HY2.5WD-4/9.5	4.0	3.15	3.2	5.7	9.5	10.7	7.6	400
	HY2.5WD-7.6/19	7.6	6.3	4.0	11.3	19.0	21.9	15.0	200
	HY2.5WD-8/18.7	8.0	6.3	6.3	11.2	18.7	21.0	15.0	200
	HY2.5WD-8/18.7	8.0	6.3	6.3	11.2	18.7	21.0	15.0	400
电机中性点接地 Motor Neutral Ground	HY2.5WD-12.7/31	12.7	10.5	6.6	18.9	31.0	35.7	25.0	200
	HY2.5WD-13.5/31	13.5	10.5	10.5	18.6	31.0	34.7	25.0	200
	HY2.5WD-13.5/31	13.5	10.5	10.5	18.6	31.0	34.7	25.0	400
	HY1.5WD-2.4/6	2.4	3.15	1.9	3.4	6.0		5.0	200
低压 Low Voltage	HY1.5WD-4.8/12	4.8	6.3	3.8	6.8	12.0		10.0	200
	HY1.5WD-8/19	8.0	10.5	6.4	11.4	19.0		15.9	200
Y1.5W0.28/1.3	Y1.5W0.28/1.3	0.28	0.22	0.24	0.6	1.3			50
	Y1.5W0.5/2.6	0.5	0.38	0.42	1.2	2.6			50

HY/Y 系列金属氧化锌避雷器 Series ZnO Surge Arrester

外形及安装尺寸 Outline & installation size

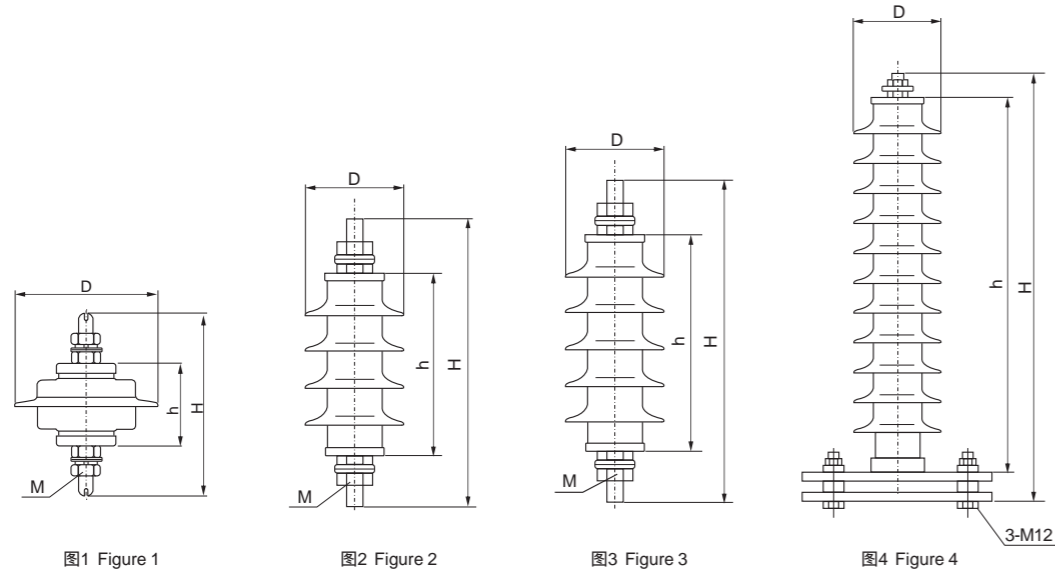

序号No.	产品型号Type	H	h	D	M	备注 Remark
1	HY1.5W-0.28/1.3	75	37	56	M6	低压避雷器 Low-voltage arrester
2	HY1.5W-0.5/2.6	75	37	56	M6	
3	HY5WS-5/15	208	132	85	M10	
4	HY5WS-10/30	208	132	85	M10	配电系统 Distribution System
5	HY5WS-17/50	258	182	90	M10	
6	HY5WZ-10/27	260	188	98	M10	
7	HY5WZ-17/45	260	188	98	M10	电站 Transformer substation
8	HY5WZ-51/134	630	555	170	M12	
9	HY5WZ-5/13.5	260	188	98	M10	
10	HY5WR-17/45	253	186	106	M12	并联补偿 电容器组 Parallel compensation capacitor banks
11	HY5WR-51/134	630	555	170	M12	
12	HY5WR-10/27	253	186	106	M12	
13	HY5WR-12.7/45	253	186	106	M12	

VS1-12 户内高压真空断路器 Indoor high voltage vacuum circuit breaker



主要用途 Application

VS1-12型户内高压真空断路器，系三相交流50Hz额定电压为12KV电力系统的户内开关设备，作为电网设备，工矿企业动力设备的保护和控制单元。适用于要求在额定工作电流下的频繁操作，或多次开断短路电流的场所。

该断路器采用操动机构于断路器本体一体式设计，即可做为固定安装单元，也可配有专用推进机构，组成手车单元作用。

VS1-12 series indoor AC high voltage vacuum breaker is used in the system of AC 50Hz, rated voltage 12KV, three phases, to protect and control the network equipment and power distribution in industrial mining enterprises. It can operate frequently at rated voltage, or break the short circuit current many times

The operating mechanism is assembled on the breaker body integrally then to be fixedly mounted, also installed on push-in mechanism and form a breaker trolley

型号及含义 Type and meaning

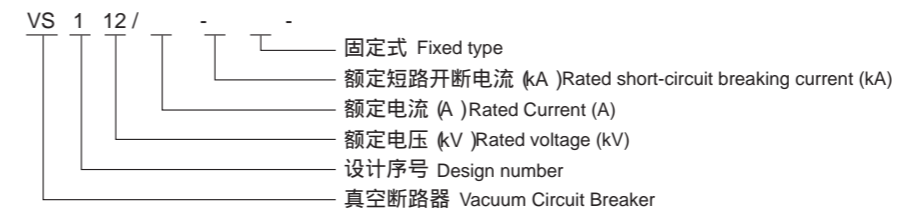

使用环境 Normal service conditions

- 周围空气温度：上限+40℃，下限-15℃；
- 海拔高度：1000m（若需增高海拔，则额定绝缘水平相应提高）；
- 振幅：地震烈度不超过8度；
- 空气相对湿度日平均值不大于95%，月平均值不大于90%；
- 无火灾、爆炸危险、严重污染、化学腐蚀及剧烈震动的场所。
- Ambient air temperature: -15℃~+40℃；
- Altitude: 1000m;(For higher altitudes, the rated insulation level corresponding increase)
- Earthquake grade less than Degree 8
- Humidity:
Daily average value of relative humidity: 95%
Monthly average value of relative humidity: 90%
- The ambient air is not significantly polluted by dust, smoke, corrosive and/or flammable gases, vapours or salt.

主要技术参数 Technical specifications

序号No.	名称 Description	单位 Unit	参数 Specifications			
1	额定电压 Rated voltage	kV	12			
2	额定频率 Rated frequency	Hz	50			
3	额定绝缘水平 Rated insulation level	1min工频耐受电压 Rated power frequency withstand voltage(1min)	对地、相间42；隔离断口48 To earth and between phases: 42; Across the isolating distances: 48			
		雷电冲击耐受电压（峰值） Rated lightning impulse withstand voltage (peak)	对地、相间75；隔离断口85 To earth and between phases: 75; Across the isolating distances: 85			
4	额定短路开断电流 Rated short circuit breaking current	kA	20	25	31.5	40
5	额定电流 Rated current	A	630	630	1250 1600	1250 1600
6	额定短时耐受电流（有效值） Rated short time withstand current	kA	20	25	31.5	40
7	额定峰值耐受电流（峰值） Rated peak withstand current	kA	50	63	80	100
8	额定短路关合电流（峰值） Rated short circuit making current	kA	50	63	80	100
9	额定短路电流持续时间 Rated short circuit current duration	s	4			
10	机械寿命 Mechanical endurance	次	20000			
11	二次回路工频耐受电压（1min） Frequency withstand voltage secondary circuit	V	2000			
12	额定操作顺序 Rated operating sequence		分-t-合分t1-合分			

注 20KA, 25KA, 31.5KA, t=0.3s t1=180s; 40kA t=180s t1=180s

外形及安装尺寸 Dimensions

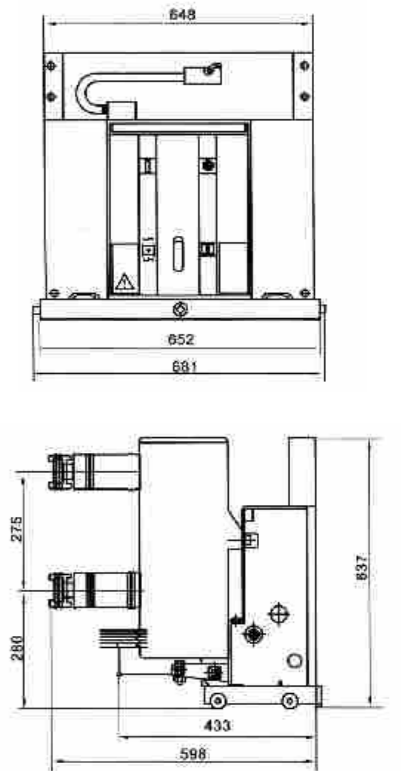

VS1-12

户内永磁高压真空断路器

Indoor permanent magnetic vacuum circuit breaker



型号及含义 Type and meaning

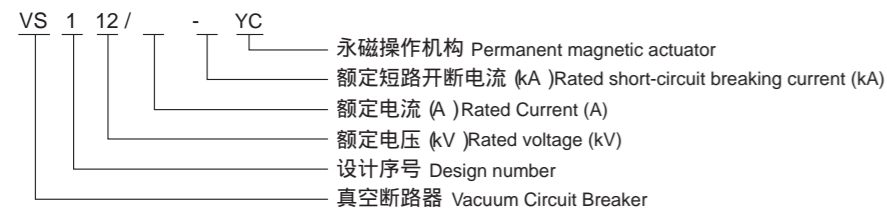

性能优点 Performance advantages

该型产品配双稳态永磁操作机构，机构内配有永磁体，由永磁体提供保持力，使开关维持在合、分闸状态，与常规弹簧操作机构相比，机械零件数量大量减少、机械传动链缩短，从而使开关可靠性大幅度提高，机械寿命大幅度增加。

This type operated with dual steady permanent magnet mechanism, the magnet body built inside the mechanism, provide holding force to remain the breaker in ON, OFF position, compared with common spring mechanism, the number of mechanical parts are reduced, mechanical driving linkage is shortened, all of these can improve the reliability of the breaker, mechanical endurance also will be increased much.

主要技术参数 Technical specifications

序号 No.	名称 Description	单位 Unit	参数 Specifications			
1	额定电压 Rated voltage	kV	12			
2	额定频率 Rated frequency	Hz	50			
3	额定绝缘水平 Rated insulation level	1min工频耐受电压 Rated power frequency withstand voltage(1min)	对地、相间42；隔离断口48 To earth and between phases: 42; Across the isolating distances: 48			
		雷电冲击耐受电压 (峰值) Rated lightning impulse withstand voltage (peak)	对地、相间75；隔离断口85 To earth and between phases: 75; Across the isolating distances: 85			
4	额定短路开断电流 Rated short circuit breaking current	kA	20	25	31.5	40
5	额定电流 Rated current	A	630	630	1250 1600	1250 1600
6	额定短时耐受电流 (有效值) Rated short time withstand current	kA	20	25	31.5	40
7	额定峰值耐受电流 (峰值) Rated peak withstand current	kA	50	63	80	100
8	额定短路关合电流 (峰值) Rated short circuit making current	kA	50	63	80	100
9	额定短路电流持续时间 Rated short circuit current duration	s	4			
10	机械寿命 Mechanical endurance	次	20000			
11	二次回路工频耐受电压 (1min) Frequency withstand voltage secondary circuit	V	2000			
12	额定操作顺序 Rated operating sequence		分 t - 合分 t1 - 合分			

注 20KA, 25KA, 31.5KA, t=0.3s t1=180s; 40kA t=180s t1=180s

主要用途 Application

VS1-12型永磁户内高压真空断路器，系三相交流50Hz额定电压为12kV电力系统的户内开关设备，作为电网设备、工矿企业动力设备的保护和控制单元。适用于要求在额定工作电流下的频繁操作，或多次开断短路电流的场所。

该断路器采用操动机构与断路器本体一体式设计，既可做为固定安装单元，也可配有专用推进机构，组成手车单元。

VS1-12 series permanent magnet type indoor AC high voltage vacuum breaker is used in the system of AC 50Hz, rated voltage 12KV, three phases, to protect and control the network equipment and power distribution in industrial mining enterprises. It can operate frequently at rated voltage, or break the short circuit current many times

The operating mechanism is assembled on the breaker body integrally then to be fixedly mounted, also installed on push-in mechanism and form a breaker trolley

外形及安装尺寸 Dimensions

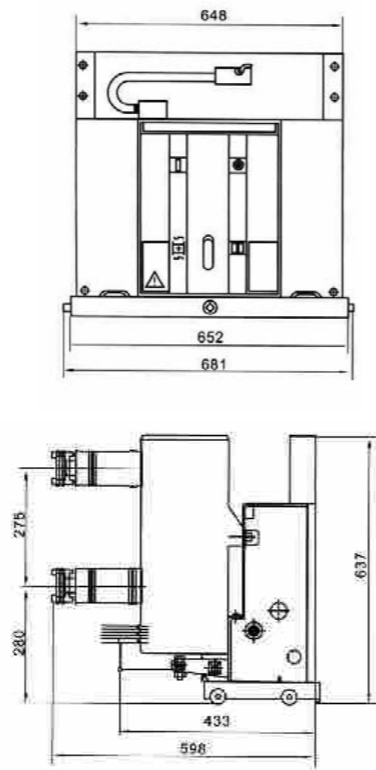

ZW8-12/630-20

户外高压真空断路器

Outdoor high voltage vacuum circuit breaker



主要用途 Application

ZW8-12/630-20型户外高压真空断路器系交流50Hz三相电力系统，主要用于开断，城市市区10KV电网的负荷电流，空载电流及短路电流，也可作农村电网和小型电力系统的分开关，是城网，农网无油化的更新换代产品。

ZW8-12/630-20 Series outdoor high voltage vacuum circuit breaker is main switch equipment of rated voltage 12KV, three phases AC 50Hz system, to switch on/off loading current, no-load current, and short circuit current, also used as the branch switch for rural power network or small power system, is a substitute for oil type breakers.

型号及含义 Type and meaning



主要技术参数 Technical specifications

名称 Description	参数 Specifications
额定电压 Rated voltage	12KV
额定电流 Rated Current	630A
工频耐受电压 Rated power frequency withstand voltage	42KV/48KV
雷电冲击耐压 (峰值) Rated lightning impulse withstand voltage (peak)	72KV/85KV
额定短路开断电流 (有效值) Rated short-circuit breaking current (rms)	20KA
额定短路关合电流 (峰值) Rated short circuit making current (peak)	50KA
额定操作顺序 Rated operating sequence	分 -0.3s合分 -180s合分
额定短路电流开断次数 Rated short-circuit current breaking times	30次
机械寿命 Mechanical endurance	10000次
额定操作电压 (合 / 分闸线圈) Rated operating voltage (close / open coil)	DC220V AC220V
动、静触头允许磨损厚度 Permissible abraded thickness of moving and static contacts	3mm
隔离断口断开距离 Across the isolating distances	≥200mm

概述 General

采用真空灭弧室，空气绝缘，配以电动弹簧操作机构，使得产品灭弧能力强，短路开断次数高，无火灾爆炸危险，操作方便，是一种性能优良，实用性较强的产品。

本产品总体结构采用三相共箱式，套管进出线，箱体内为干燥空气，电动弹簧操作机构布置在箱体的侧面，可在较严酷的环境条件下可靠使用。

本产品真空灭弧室采用陶瓷外壳，杯状纵磁场触头结构，铜钨触头材料，具有优良的开断和关合短路电流能力。

该产品体积小，重量轻，外型美观。真空灭弧室和绝缘支持套管设计紧，出线导电杆外注硅橡胶，能适应恶劣的气候条件和污秽环境。

Vacuum interrupter is used, air insulated, operated with motor spring mechanism, which can ensure high arc extinguishing ability, many times of breaking short circuit, no fire and explosion risk, easy operation, which is a perfect and practical HV breaker.

The overall structure constructed as three phase in a tank, conductor passing through bushings, it is dry air in the tank, motor spring mechanism assembled on the tank side, it can operate under some severe ambient conditions.

The vacuum interrupter shell is made of porcelain material, the main contacts are of cup-shaped producing transverse magnetic field, as Cu and Cr material, realize perfect short circuit interrupting and making level.

This product has small size, light weight, good figure, vacuum interrupter and insulated bushing are compact, outgoing conductive rod will enclosed with silicone rubber, it can operate under some severe ambient conditions

外形及安装尺寸 Dimensions

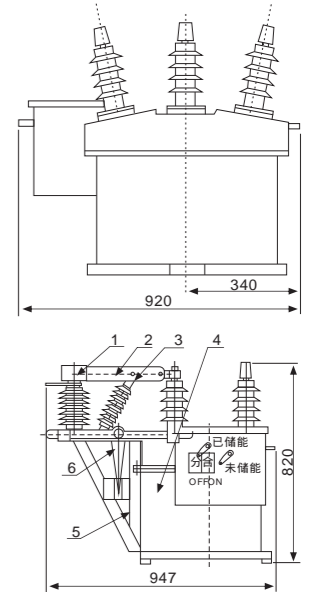

- 1、静触头 Static contact
- 2、动触头 Moving contact
- 3、绝缘拉杆 Insulated pulling rod
- 4、断路器 Breaker
- 5、隔离刀支架 Support of isolating blade
- 6、支柱绝缘子 Supporting insulator

ZW32-12

型户外真空断路器

Outdoor vacuum circuit breaker

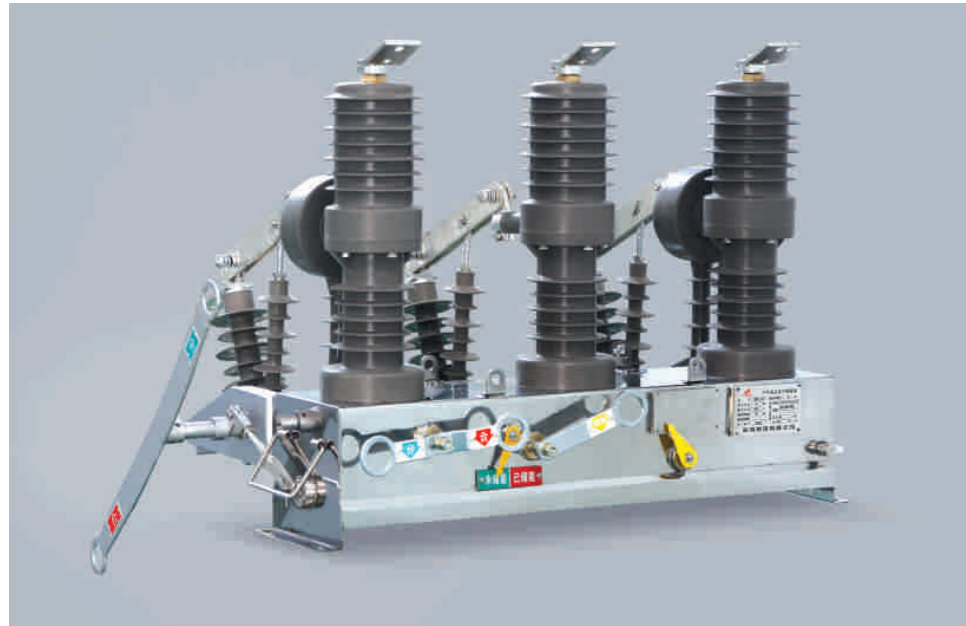

型号及含义 Type and meaning

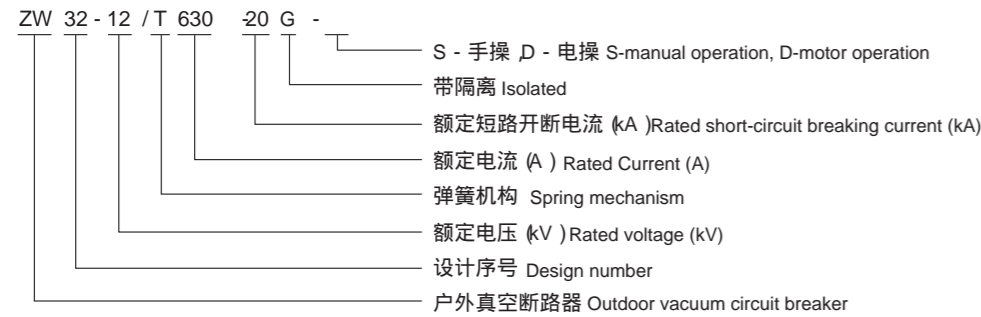

主要技术参数 Technical specifications

序号 No.	名称 Description	单位 Unit	参数 Specifications
1	额定电压 Rated voltage	KV	12
2	额定频率 Rated frequency	Hz	50
3	额定电流 Rated current	A	630
4	额定短路开断电流 Rated short circuit breaking current	KA	20
5	额定峰值耐受电流(峰值) Rated peak withstand current(peak)	KA	50
6	额定短时耐受电流 Rated short time withstand current	KA	20
7	额定短路关合电流(峰值) Rated short circuit making current(peak)	KA	50
8	机械寿命 Mechanical endurance	次	10000
9	额定短路开断电流开断次数 Rated short-circuit current breaking times	次	30
10	工频耐受电压(1min): (湿)(干)相间, 对地/断口 Rated power frequency withstand voltage(1min): (Wet), (dry) To earth and between phases / Across the isolating distances	KV	42 / 48
11	雷电冲击耐受电压(峰值)相间, 对地/断口 Rated lightning impulse withstand voltage (peak) To earth and between phases / Across the isolating distances	KV	75 / 85
12	二次回路1min工频耐压 Frequency withstand voltage secondary circuit	KV	2

概述 General

ZW32-12型户外真空断路器(以下简称断路器)为额定电压12KV,三相交流50Hz的户外配电设备。主要用于开断,关合电力系统中的负荷电流,过载电流及短路电流。适用于变电站及工矿企业配电系统中作保护和控制之用,及农村电网频繁操作的场所。

本断路器具有体积小,重量轻,防凝露,免维护等特点,能适应较恶劣的气候条件和污秽环境。

ZW32-12 Series outdoor high voltage vacuum circuit breaker(hereinafter call breaker) is used in the three phase power system of AC 50Hz, voltage 12KV, to switch on/off loading current, overloading current and short circuit currents. It suits for protecting and control distribution system of substation, industrial enterprises, and frequent switching in rural network.

This product has small size, light weight, dew proof, and free of maintenance, it can operate under some severe ambient conditions and on polluted site

符合标准 Complied standard

- GB1984 《交流高压断路器》
- GB11022 《高压开关设备和控制设备标准的共同技术要求》
- GB311.1-6 《高压输电设备的绝缘配合》
- GB763 《交流高压电器在长期工作时的发热》
- GB2706 《交流高压电器动,热稳定试验方法》
- GB3309 《高压开关设备在常温下的机械试验》
- DL/T593 《高压开关设备的共同订货技术条件》
- GB1984 "AC high voltage circuit breakers"
- GB11022 "Common specifications for high-voltage switchgear and controlger"
- GB311.1-6 "insulation co-ordination for high voltage transmission and distribution equipment."
- GB763 "AC high voltage electrical work in the long term fever."
- GB2706 "Dynamic and thermal stability test method for AC high voltage electrical"
- GB3309 "high voltage switchgear mechanical tests at room temperature."
- DL/T593 "Common specifications for high-voltage switchgear and controlger"

外形及安装尺寸 Dimensions

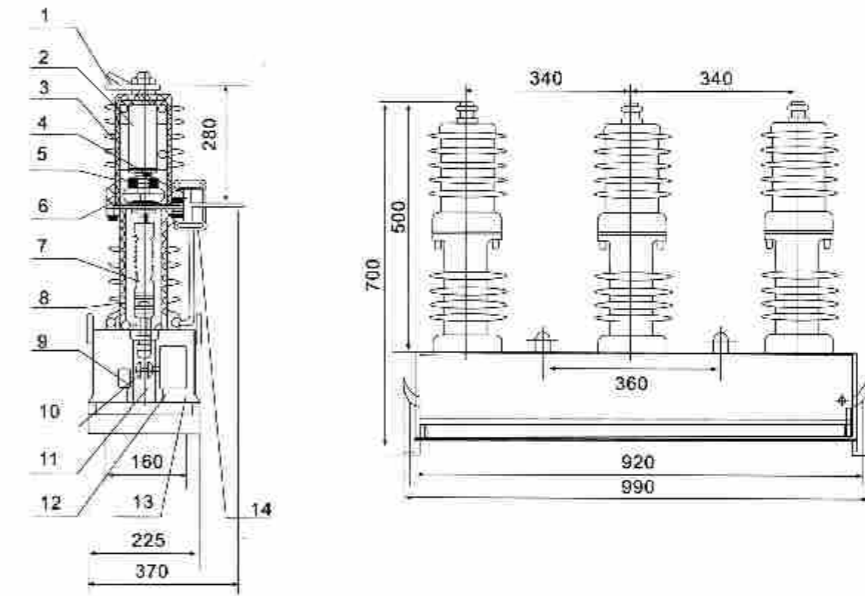

- | | | | | |
|------------------------|--------------------|----------------------------|----------------------|-------------------|
| 1. 上出线 | 4. 下出线 | 7. 绝缘拉杆 | 10. 驱动连板 | 13. 机构箱 |
| 2. 灭弧室 | 5. 导电夹 | 8. 触头压力弹簧 | 11. 机构输出轴 | 14. 电流互感器 |
| 3. 绝缘筒 | 6. 软联结 | 9. 分闸弹簧 | 12. 操动机构 | |
| 1. Upper outgoing | 4. Lower outgoing | 7. Insulated rod | 10. Drive even board | 13. Mechanism box |
| 2. Arc chamber | 5. Conductive clip | 8. Contact pressure spring | 11. Output shaft | 14. CT |
| 3. Insulation cylinder | 6. Soft links | 9. Opening spring | 12. Actuator | |

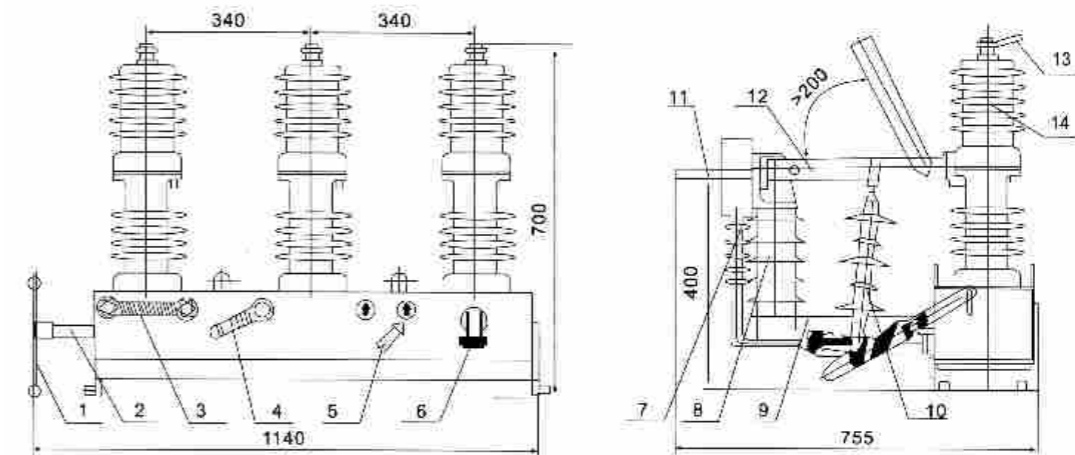

- | | | | | |
|------------------------------------|-------------------------------|------------------------|------------------------------|------------------|
| 1. 操作手柄 | 4. 断路器储能受柄 | 7. 电流互感器 | 10. 绝缘拉杆 | 13. 接地板 |
| 2. 隔离主轴 | 5. 分合批示 | 8. 绝缘子 | 11. 接线板(进线端) | 14. 断路器 |
| 3. 断路器手动分合手柄 | 6. 接线插头 | 9. 隔离架 | 12. 隔离刀片 | |
| 1. Operating handle | 4. Breaker tank by the handle | 7. Current Transformer | 10. Insulated rod | 13. Ground plate |
| 2. Isolated spindle | 5. Division instructions | 8. Insulator | 11. Wiring board (line side) | 14. Breaker |
| 3. Breaker manual division handles | 6. Wiring plug | 9. Spacer | 12. Isolated blades | |

ZW32-12 户外永磁真空断路器

Outdoor permanent magnetic vacuum circuit breaker



型号及含义 Type and meaning

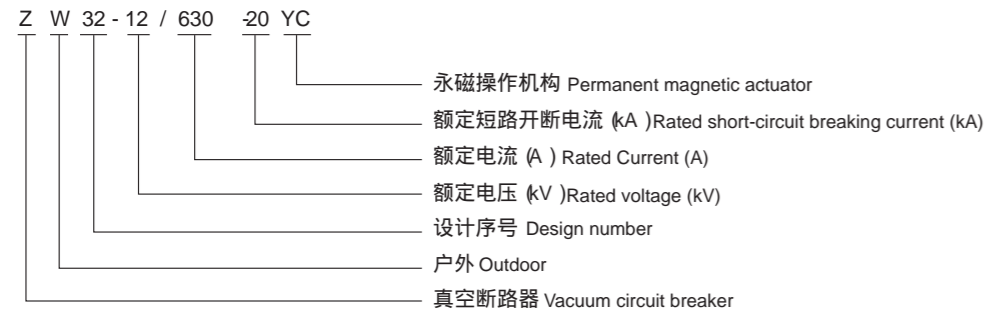

主要技术参数 Technical specifications

序号 No.	名称 Description	单位 Unit	参数 Specifications
1	额定电压 Rated voltage	KV	12
2	额定频率 Rated frequency	Hz	50
3	额定电流 Rated current	A	630
4	额定短路开断电流 Rated short circuit breaking current	KA	20
5	额定峰值耐受电流(峰值) Rated peak withstand current(peak)	KA	50
6	额定短时耐受电流 Rated short time withstand current	KA	20
7	额定短路关合电流(峰值) Rated short circuit making current(peak)	KA	50
8	机械寿命 Mechanical endurance	次	10000
9	额定短路开断电流开断次数 Rated short-circuit current breaking times	次	30
10	工频耐受电压(1min): (湿)(干)相间, 对地/断口 Rated power frequency withstand voltage(1min): (Wet), (dry) To earth and between phases / Across the isolating distances	KV	42 / 48
11	雷电冲击耐受电压(峰值)相间, 对地/断口 Rated lightning impulse withstand voltage (peak) To earth and between phases / Across the isolating distances	KV	75 / 85
12	二次回路1min工频耐压 Frequency withstand voltage secondary circuit	KV	2

概述 General

ZW32-12型永磁户外真空断路器(以下简称断路器)为额定电压12kV,三相交流50Hz的户外配电设备。主要用于开断、关合电力系统中的负荷电流、过载电流及短路电流。适用于变电站及工矿企业配电系统中作保护和控制之用,及农村电网频繁操作的场所。

本断路器具有体积小、重量轻、防凝露、免维护等特点,能适应较恶劣的气候条件和污秽环境。

ZW32-12 Series permanent magnet type outdoor high voltage vacuum circuit breaker (hereinafter call breaker) is used in the three phase power system of AC 50Hz, voltage 12KV, to switch on/off loading current, overloading current and short circuit currents. It suits for protecting and control distribution system of substation, industrial enterprises, and frequent switching in rural network.

This product has small size, light weight, dew proof, and free of maintenance, it can operate under some severe ambient conditions and on polluted site

性能优点 Performance advantages

该产品采用永磁操作机构进行操作;由于永磁操作机构永磁体提供保持力,使开关保持在分合闸位置,其机械零件数量少、机械传动链短,从而大大提高了开关的可靠性和机械寿命。

This breaker adopted permanent magnet operating mechanism, which can provide holding force by permanent magnet, the breaker can be remained in OFF position, components and parts used in the breaker are few, mechanical driving is simple and short, which can improve the reliability and mechanical endurance very much.

外形及安装尺寸 Dimensions

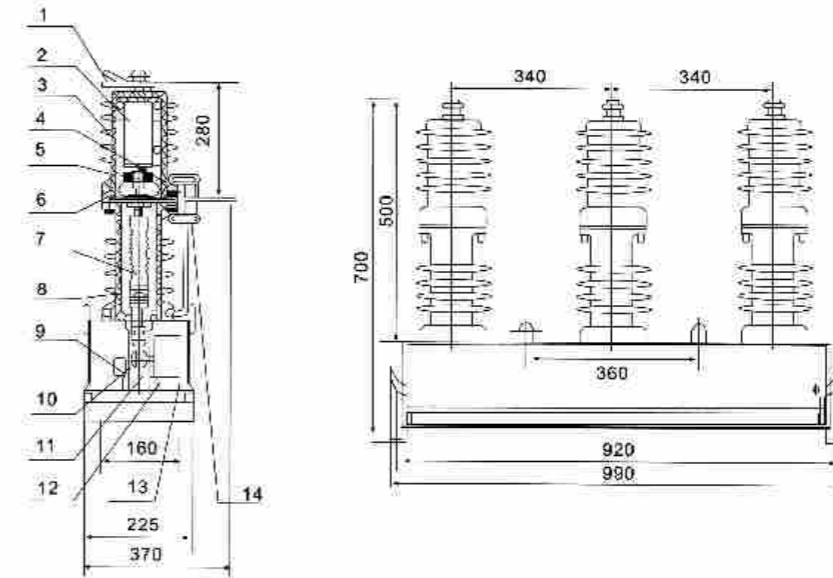

- | | | | | |
|------------------------|--------------------|----------------------------|----------------------|-------------------|
| 1. 上出线 | 4. 下出线 | 7. 绝缘拉杆 | 10. 驱动连板 | 13. 机构箱 |
| 2. 灭弧室 | 5. 导电夹 | 8. 触头压力弹簧 | 11. 机构输出轴 | 14. 电流互感器 |
| 3. 绝缘筒 | 6. 软联结 | 9. 分闸弹簧 | 12. 操动机构 | |
| 1. Upper outgoing | 4. Lower outgoing | 7. Insulated rod | 10. Drive even board | 13. Mechanism box |
| 2. Arc chamber | 5. Conductive clip | 8. Contact pressure spring | 11. Output shaft | 14. CT |
| 3. Insulation cylinder | 6. Soft links | 9. Opening spring | 12. Actuator | |

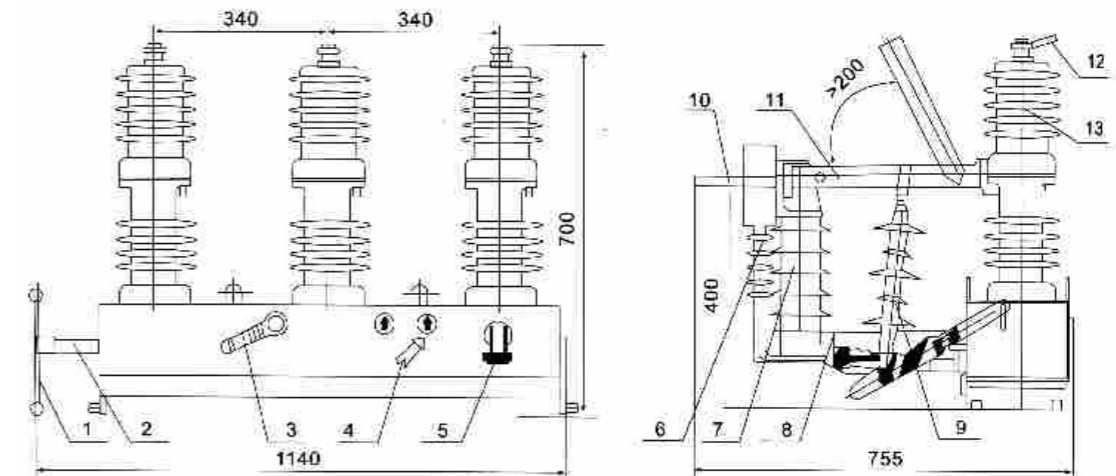

- | | | | | |
|---------------------|--------------------------|------------------|----------------------------------|-------------|
| 1. 操作手柄 | 4. 分合批示 | 7. 绝缘子 | 10. 接线板(进线端) | 13. 断路器 |
| 2. 隔离主轴 | 5. 接线插头 | 8. 隔离架 | 11. 隔离刀片 | |
| 3. 分闸手柄 | 6. 电流互感器 | 9. 绝缘拉杆 | 12. 接地板(出线端) | |
| 1. Operating handle | 4. Division instructions | 7. Insulator | 10. Wiring board (Incoming side) | 13. Breaker |
| 2. Isolated spindle | 5. Wiring plug | 8. Spacer | 11. Isolated blades | |
| 3. Division handles | 6. Current Transformer | 9. Insulated rod | 12. Ground plate (Outgoing side) | |

FZN25-12

户内真空负荷开关 - 熔断器组合电器

Indoor high-voltage load switch and fuse combination

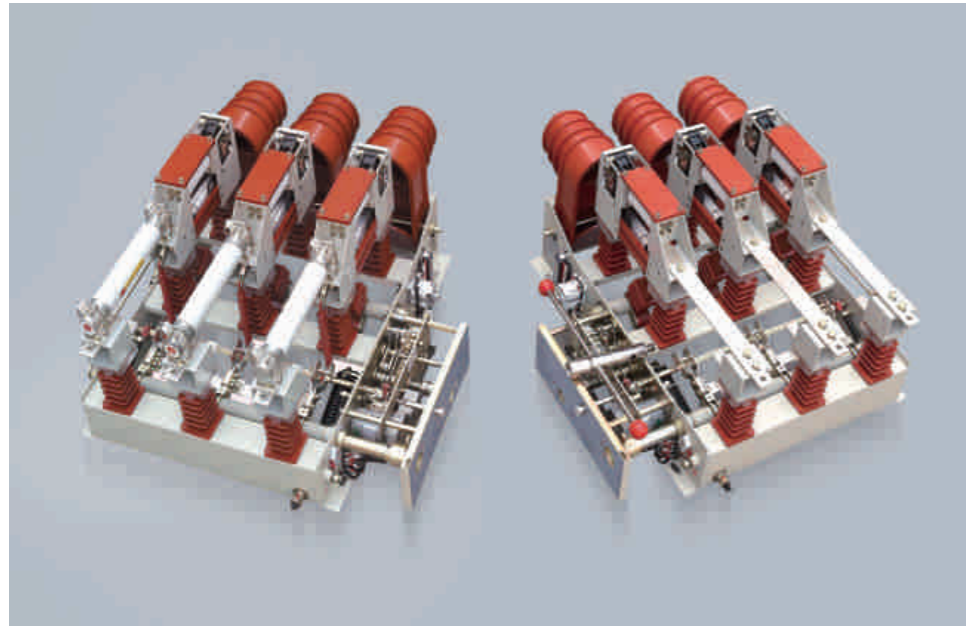

型号及含义 Type and meaning

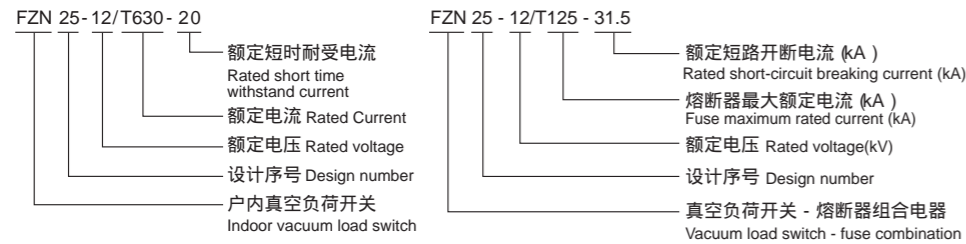

主要技术参数 Technical specifications

序号 No.	名称 Description	单位 Unit	参数 Specifications	
		FZN25-12D/T630-20		FZN25-12D/T125-31.5
1	额定电压 Rated voltage	kV	12	
2	额定频率 Rated frequency	Hz	50	
3	额定电流 Rated current	A	630	125
4	额定绝缘水平 Rated insulation level	kV	1min工频耐受电压 Rated power frequency withstand voltage(1min)	
	雷电冲击耐受电压 (峰值) Rated lightning impulse withstand voltage (peak)		对地、相间75; 隔离断口85 To earth and between phases: 75; Across the isolating distances: 85	
5	额定动稳定电流 (峰值) Rated peak withstand current	kA	50	-
6	热稳定电流 Rated short time withstand current	kA	20	-
7	额定有功负载开断电流 Rated active load breaking current	A	630	125
8	额定闭环开断电流 Rated closed loop breaking current	A	630	125
9	额定电缆充电开断电流 Rated cable charging breaking current	A	10	10
10	开断空载变压器容量 Capacity of breaking non-load transformer	kVA	1250	1250
11	额定短路开断电流 Rated short-circuit breaking current	kA	-	31.5
12	额定转移电流、额定交接电流 Rated transfer current	A	-	2000
13	熔断器型号 Fuse Type		-	SDLAJ-12 SFLAJ-12
14	撞击器输出能量 Output energy by striker	J	-	2-5 (中等)
15	额定短路关合电流 Rated short-circuit current	kA	50	
16	接地开关额定动稳定电流 Earthing switch rated peak withstand current	kA	50	
17	接地开关2S热稳定电流 Earthing switch rated short time withstand current	kA	20	
18	辅助回路额定电压 Rated auxiliary circuit voltage	V	AC DC220 /110	
19	机械寿命次 Mechanical endurance	次	10000	

概述 General

FZN25、FZRN25型真空负荷开关组合电器，适用三相交流50Hz环网或终端供电和工业用电设备中，作负荷控制和短路保护之用，负荷开关分合负荷、闭环电流、空载变压器和电缆充电电流。组合电器可以开断直至额定短路电流的任何电流。采用直动式隔离断口和真空灭弧室联动。具有手动和电动功能。

FZN25、FZRN25独特的传动结构设计，灭弧室仅在关合和开断的瞬间承受高压，故体积小，重量轻。

FZN25、FZRN25可实现隔离断口和灭弧室断口的一次性操作。

FZN25、FZRN25在静触头与动触头导电筒之间有与接地开关互为联动的接地活门，既保证了安全又方便了检修。

FZN25, FZRN25 type vacuum load switch and fuse switch, suitable for three-phase AC 50Hz ring main network or terminal power supply and industrial electrical equipment, for load control and short circuit protection use, load switch open and close the closed loop current, no-load transformer and cable charging current, fuse switch can break any current till rated short circuit current. It adopts the straight move or isolating fracture and vacuum interrupter linkage with function of manual and electric operation.

FZN25, FZRN25 special transmission structure design, arc extinguish chamber only withstand voltage in the moment of closing and breaking, small size, light weight.

FZN25, FZRN25 can perform one operation to realize isolation break and arc extinguish chamber break.

FZN25, FZRN25 has an earthing shutter between the static contact and conductive cylinder of the moving contact, the shutter will be interlocked with earthing switch which ensures safety and convenient maintenance.

外形及安装尺寸 Dimensions

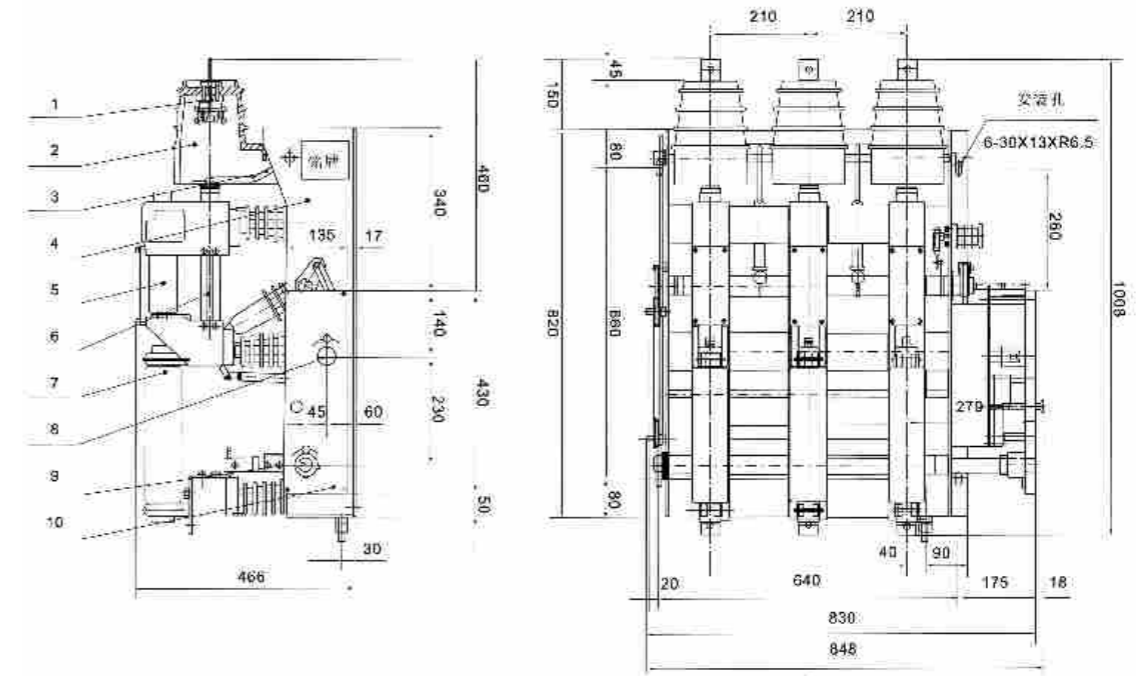

FZRN25-12D/125-31.5真空负荷开关 - 熔断器组合电器外形及安装尺寸
FZRN25-12D/125-31.5 Vacuum load switch - fuse combination dimensions

1. 静触头
 2. 绝缘罩
 3. 活门
 4. 机架
 5. 真空灭弧室
 6. 导电筒
 7. 熔断器
 8. 储能轴
 9. 接地刀轴
 10. 操作面板
1. Static contact
 2. Insulation cover
 3. Valve
 4. Rack
 5. Vacuum interrupter
 6. Flashlight
 7. Fuses
 8. Storage shaft
 9. Ground arbor
 10. Operation Panel

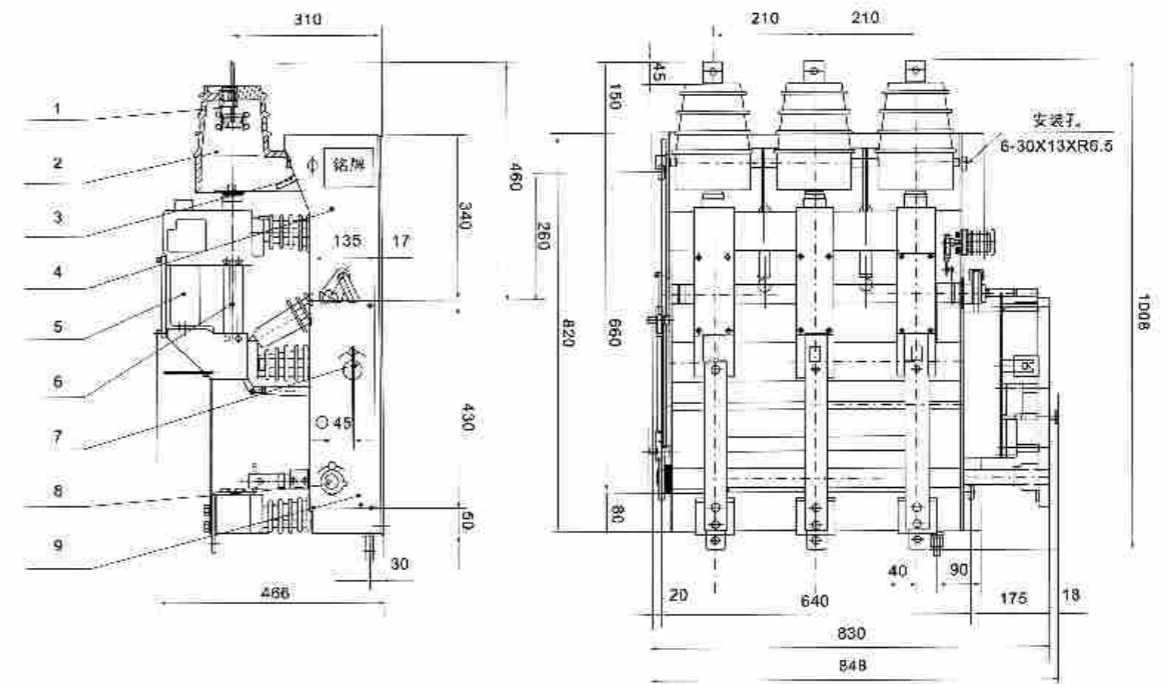

FZRN25-12D/630-20真空负荷开关 - 熔断器组合电器外形及安装尺寸
FZRN25-12D/630-20 Vacuum load switch - fuse combination dimensions

1. 静触头
 2. 绝缘罩
 3. 活门
 4. 机架
 5. 真空灭弧室
 6. 导电筒
 7. 熔断器
 8. 储能轴
 9. 接地刀轴
1. static contact
 2. Insulation cover
 3. Valve
 4. Rack
 5. Vacuum interrupter
 6. Flashlight
 7. Fuses
 8. Storage shaft
 9. Ground arbor

FZN21-12

户内真空负荷开关 - 熔断器组合电器

Indoor high-voltage load switch and fuse combination



型号及含义 Type and meaning

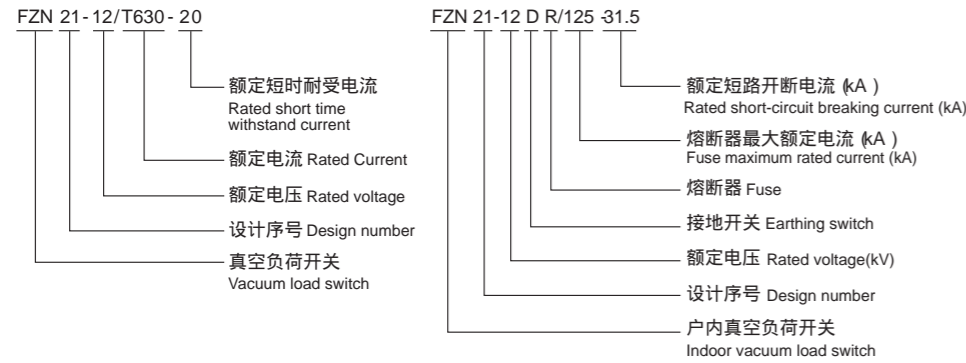

主要技术参数 Technical specifications

序号 No.	名称 Description	单位 Unit	参数 Specifications	
			FZN21	FZRN21
1	额定电压 Rated voltage	kV	12	12
2	额定电流 Rated current	A	630	1250
3	额定短路关合电流 Rated short circuit making current	kA	50	50
4	额定短路开断电流 (组合电器) Rated short circuit breaking current	kA	-	31.5
5	额定有功负载开断电流 Rated active load breaking current	A	630	630
6	4s热稳定电流 Rated short time withstand current 4s	kA	20	-
7	动稳定电流 Rated peak withstand current	kA	50	-
8	1min工频耐受电压 Rated power frequency withstand voltage(1min)	kA	42(断口48)	42(断口48)
9	雷电冲击耐受电压 Rated lightning impulse withstand voltage (peak)	kA	75(断口85)	75(断口85)
10	机械寿命 Mechanical endurance	次	1000	1000
11	额定转移电流 (组合电器) Rated transfer current(Combination)	V	-	3150
12	电动机操作电源电压 Motor operating supply voltage	A	交直流110、220	交直流110、220

概述 General

FZN21-12D/T630-20, FZN21-12DR/T125-31.5型高压真空负荷开关及组合电器用于三相交流12kV、50Hz的配电系统中,具有结构紧凑、体积小、重量轻、寿命长、关合开断能力强、安全可靠等优点,与熔断器配合使用(简称组合电器),可替代造价较高的熔断器,其操作和维护简单方便。

FZN21-12D/T630-20, FZN21-12DR/T125-31.5 type high-voltage vacuum load break switch and fuse switch are operating in three-phase AC electrical 12kV, 50Hz power distribution system, with a compact, small size, light weight, long service life, high making and breaking ability, safe and reliable, and if load switch cooperated with fuse namely fuse switch can replace those fuses with higher cost, easy and convenient operation and maintenance

使用环境 Normal service conditions

- 海拔高度 1000m ;
- 周围环境温度-25 ~ +40 ;
- 相对湿度: 日平均值不大于95%, 月平均值不大于90% ;
- 无导电性尘埃、腐蚀性气体和水蒸气的场所; 无火灾和爆炸危险的场所;
- 无剧烈振动、倾斜度小于3°的场所。

- Altitude: 1000m
- Ambient air temperature: -15 ~+40 ,
- Humidity: Daily average value of relative humidity: 95% Monthly average value of relative humidity: 90%
- The ambient air is not significantly polluted by dust, smoke, corrosive and/or flammable gases, vapours or salt.
- No severe vibration, inclination of less than 3° place.

结构特点、性能 (及外形安装尺寸, 见图)

FZN21-12型负荷开关及组合电器主要由框架、隔离开关(或熔断器充电隔离开关)、真空灭弧室、接地开关、操作机构等组成。

本产品结构紧凑、体积小、寿命长,关合开断能力强、操作维护简便。真空开关配有电操作机构和储能弹簧,可实现快速合分操作。隔离开关、真空开关,接地开关之间互相关联锁,以防止误操作。

FZN21-12 type load switch and fuse switch mainly consists of frame, isolator (or fuse isolator), vacuum interrupter, earth switch, operating mechanism and etc.

The switch is compact, small size, long service life, high making and breaking ability, easy and convenient operation and maintenance. The load switch assembled with motor mechanism and spring, to perform fast closing and opening operation. There will provide interlocks between isolator, vacuum interrupter, earth switch, to prevent wrong and unauthorized operation

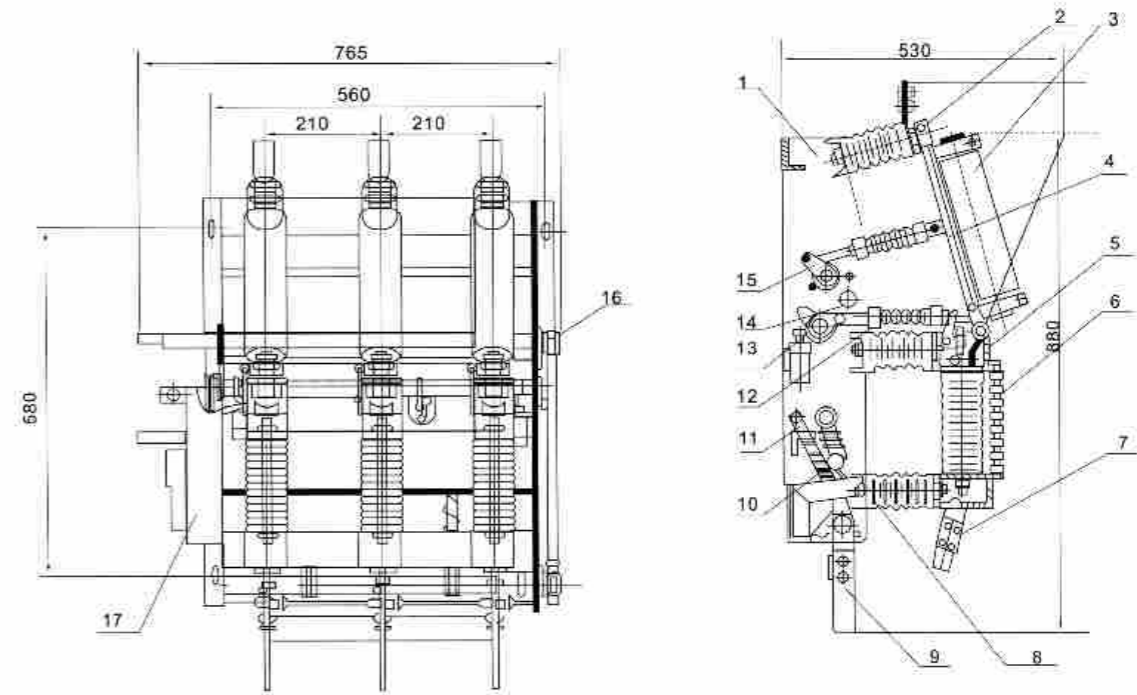

- | | | | | |
|---------|----------|---------|---------|-------|
| 1、框架 | 2、隔离刀 | 3、熔断器 | 4、绝缘拉杆 | 5、上支架 |
| 6、灭弧室 | 7、接地刀静触头 | 8、绝缘子 | 9、接地刀 | |
| 10、接地弹簧 | 11、分闸弹簧 | 12、绝缘拉杆 | 13、主轴 | |
| 14、脱扣机构 | 15、付轴 | 16、联动拉杆 | 17、操作机构 | |

负荷开关无熔断器(项3)和脱扣机构(项14)
The load switch without fuse (3) and tripping mechanism(14)

订货须知 Ordering Information

订货时须说明产品的型号、名称、规格、数量、操作机构电压。
Shall state the type, name, size, quantity, operating mechanism voltage products when ordering.

FZN21-12

户内真空负荷开关 - 熔断器组合电器

Indoor high-voltage load switch and fuse combination

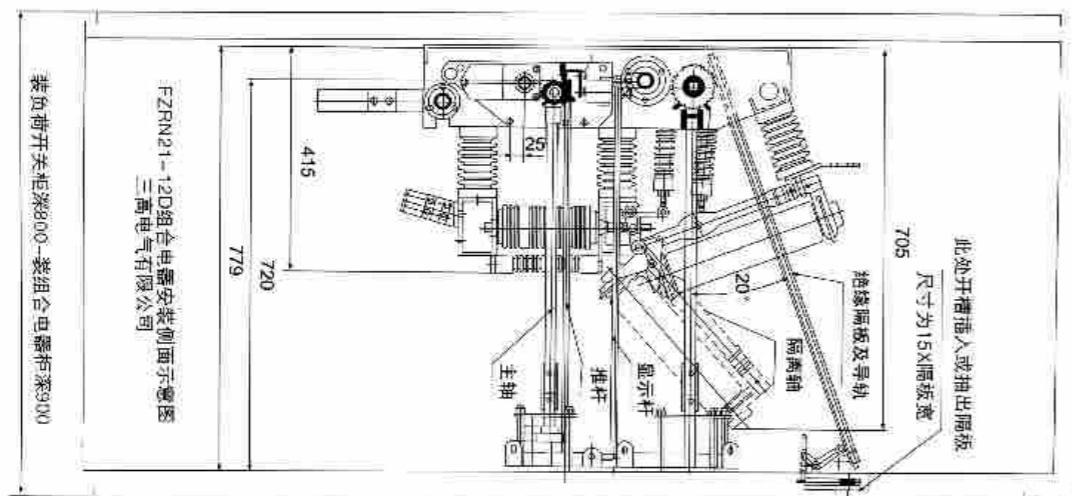
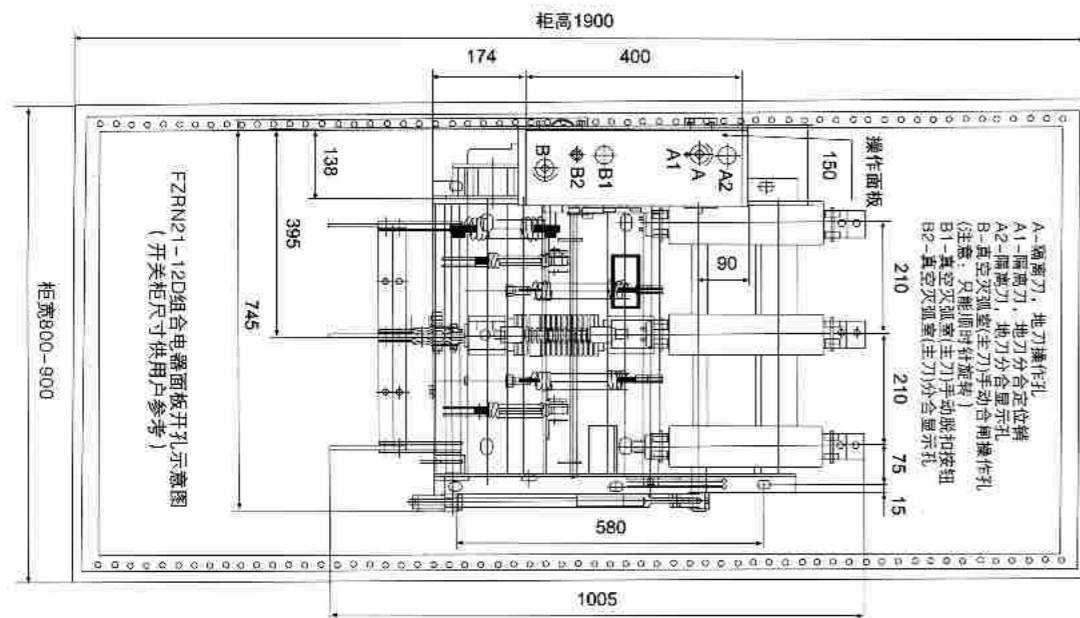

FZN21-12D/T630-20, FZN21-12DR/T125-31.5户内真空负荷开关 - 熔断器组合电器外型尺寸图
FZN21-12D/T630-20, FZN21-12DR/T125-31.5 Indoor Vacuum load switch - fuse combination dimensions

FN12-12

户内高压负荷开关 - 熔断器组合电器

Indoor high-voltage load switch and fuse combination



概述 General

FN12-12D和FN12-12DR组合电器是额定电压12kV、额定频率50Hz的三相高压开关设备用于分合负荷电流、闭环电流、空载变压器和电缆充电电流、关合短路电流、熔断器组合电器可开断短路电流, 配装接地开关的负荷开关, 可以承受短路电流, 主要用于三相环网或终端供电的市区配电站和工业用电设备中, 作负荷控制和短路保护作用。

FN12-12D and FN12-12DR load break switch and fuse switch is a three phase H.V. switch equipment of 12KV, 50Hz for breaking or closing load current, no-load transformer and cable charging current and closing short-circuit current. The fuse switch can break short circuit current, the load switch with earth switch can withstand short-circuit current. It is especially suitable for ring main network or terminal power supply substation, to control load and protect from short circuit.

型号及含义 Type and meaning

FN 12-12 D/630 -20 -

机械形式: S - 手操,
D - 电动机操
Operation: S-Manual operation,
D-motor operation
额定热稳定电流 (kA)
Rated short time
withstand current (kA)
额定有功负载电流 (A)
Rated active load current (A)
接地开关 Earthing switch
额定电压 Rated voltage (kV)
设计序号 Design number
户内交流高压负荷开关
Indoor AC high voltage
load switch

FN 12-12 D R/125 31.5 -

机械形式: S - 手操,
D - 电动机操
Operation: S-Manual operation,
D-motor operation
额定短路开断电流 (kA)
Rated short-circuit breaking current (kA)
熔断器最大额定电流 (kA)
Fuse maximum rated current (kA)
熔断器 Fuse
接地开关 Earthing switch
额定电压 Rated voltage(kV)
设计序号 Design number
交流高压负荷开关 - 熔断器
组合电器
AC high voltage load switch -
fuse combination

主要技术参数 Technical specifications

序号 No.	名称 Description	单位 Unit	FN12-12/630	FNR12-12/100-31.5
1	额定电压 Rated voltage	kV	12	
2	额定频率 Rated frequency	Hz	50	
3	额定电流 Rated current	A	630	125
4	雷电冲击耐受电压 (峰值) Rated lightning impulse withstand voltage (peak)	kV	对地、相间75; 隔离断口85 To earth and between phases: 75; Across the isolating distances: 85	
5	1min工频耐受电压 Rated power frequency withstand voltage(1min)	kV	对地、相间42; 隔离断口48 To earth and between phases: 42; Across the isolating distances: 48	
6	额定热稳定电流 Rated short time withstand current	kA	20(4S)	
7	额定动稳定电流 Rated peak withstand current	kA	50	
8	额定短路关合电流 (峰值) Rated short circuit making current(peak)	kA	50	50
9	额定短路开断电流 (预期值) Rated short circuit breaking current	kA		31.5
10	额定转移电流 Rated transfer current	kA		1.5
11	开断空载变压器容量 Capacity of breaking non-load transformer	kVA	1250	
12	额定电缆充电电流 Rated cable charging current	A	10	
13	机械寿命 Mechanical endurance	次	4000	
14	熔断器触发负荷开关分闸时间 Opening time of load disconnecter triggered by striker	s		<0.6
15	接地开关热稳定电流 Short-time withstand current of earthing switch	kA	20(2s)	
16	接地开关动稳定电流 (峰值) Peak withstand current of earthing switch	kA	50	
17	控制回路电源电压 Control circuit supply voltage		AC/DC110/220	

FN12-12

户内高压负荷开关 - 熔断器组合电器

Indoor high-voltage load switch and fuse combination

外形及安装尺寸 Dimensions

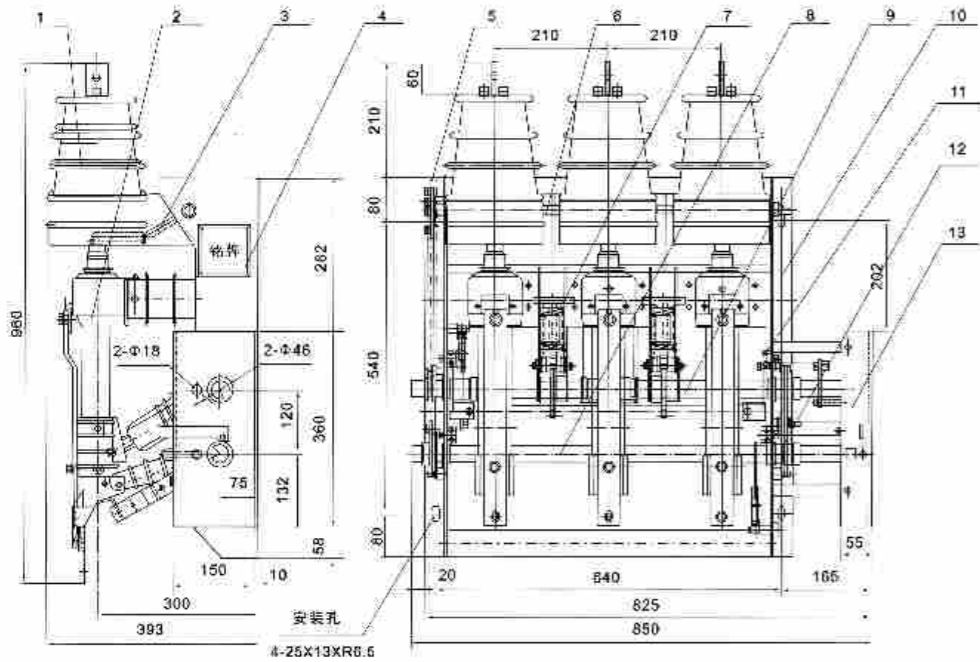

FN12-12D/630-20户内交流高压负荷开关外形及安装尺寸
FN12-12D/630-20 AC high-voltage load switch dimensions

- 1.静触头部装
 - 2.动触头部装
 - 3.绝缘活门组装
 - 4.铭牌
 - 5.活门联动机构
 - 6.活门轴组装
 - 7.操作机构组装
 - 8.地刀轴组装
 - 9.主轴转动轴组装
 - 10.机架焊接
 - 11.加冲器组装
 - 12.联锁机构组装
 - 13.操作面板级装
- 1.Head mounted static contact
 - 2.Head mounted movable contact
 - 3.Insulation valve assembly
 - 4.Nameplate
 - 5.Valve linkage
 - 6.Valve shaft assembly
 - 7.Operating mechanism assembly
 - 8.To knife shaft assembly
 9. Spindle rotation axis assembly
 - 10.Rack welding
 - 11.Plus punch assembly
 - 12.Interlocking mechanism assembly
 - 13.Mounted control panel level

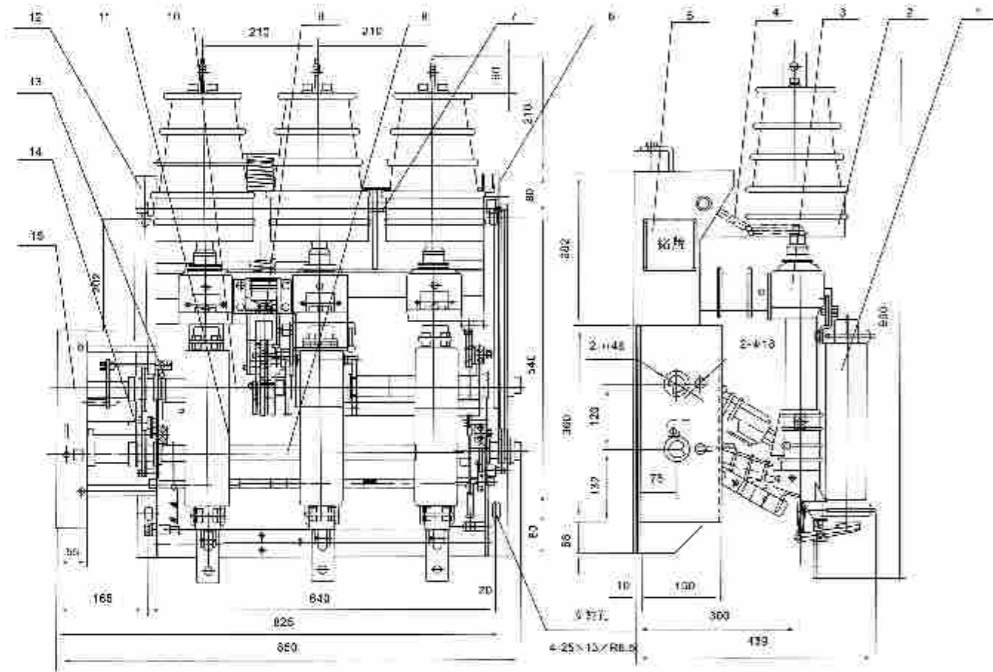

FN12-12DR/100-31.5交流高压负荷开关 - 熔断器组合电器外形及安装尺寸
FN12-12DR/100-31.5 AC high-voltage load switch and fuse combination dimensions

- 1.熔断器
 - 2.静触头部装
 - 3.动触头部装
 - 4.绝缘活门组装
 - 5.铭牌
 - 6.活门联动机构
 - 7.活门联动机构
 - 8.地刀轴组装
 - 9.操作机构组装
 - 10.主轴转动轴组装
 - 11.脱扣轴组装
 - 12.机架焊接
 - 13.回冲器组装
 - 14.联锁机构组装
 - 15.操作面板级装
- 1.Fuse
 - 2.Static contact head mounted
 - 3.Head mounted movable contact
 - 4.Insulation valve assembly
 - 5.Nameplate
 - 6.Valve linkage
 - 7.Valve linkage
 - 8.To knife shaft assembly
 - 9.Operating mechanism assembly
 - 10.Spindle rotation axis assembly
 - 11.Trip shaft assembly
 - 12.Rack welding
 - 13.Back to the punch assembly
 - 14.Interlocking mechanism assembly
 - 15.The operator panel assembly

FN7-12

系列户内高压负荷开关及熔断器组合电器

Indoor AC high-voltage load switch and fuse combination

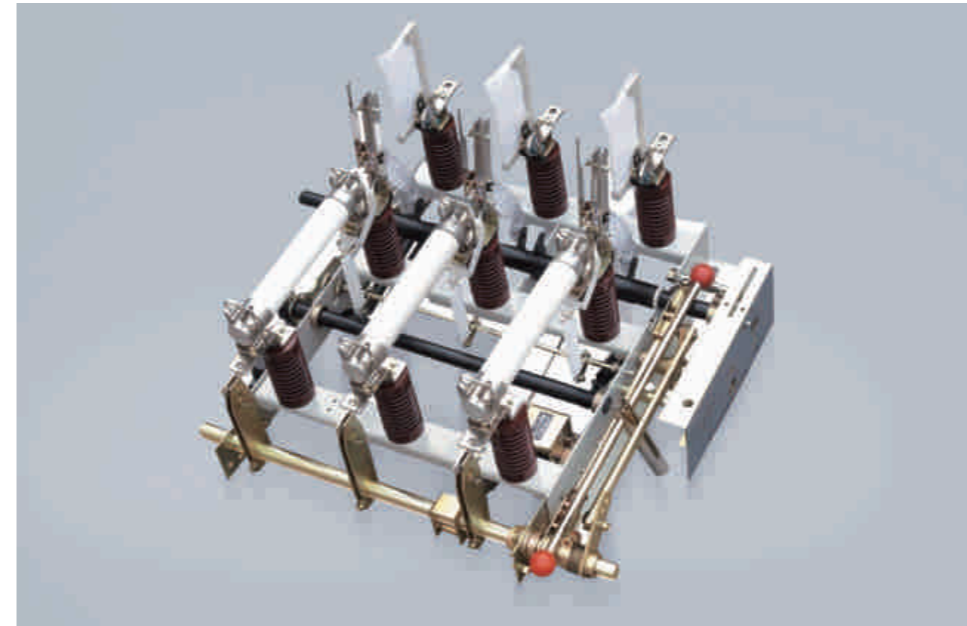

主要技术参数 Technical specifications

名称 Description	单位 Unit	参数 Specifications	
额定电压 Rated voltage	kV	12	
额定绝缘水平 Rated insulation level	1min工频耐受电压 Rated power frequency withstand voltage(1min)	kV	对地、相间42； To earth and between phases: 42； 隔离断口48 Across the isolating distances: 48
	雷电冲击耐受电压(峰值) Rated lightning impulse withstand voltage (peak)	kV	对地、相间75； To earth and between phases: 75； 隔离断口85 Across the isolating distances: 85
额定电流 Rated current	A	400	630
额定热稳定电流(有效值) Rated short time withstand current	kA	12.5	20
额定动稳定电流(峰值) Rated peak withstand current(peak)	kA	31.5	50
额定短路关合电流(峰值) Rated short circuit making current	kA	31.5	50

主要规格 Main Specifications

名称 Name	全型号 All models	DS	DX	L	R	RA	F	用途 Application
		接地开关在进线端 Earth switch in the incoming (source) side	接地开关在出线端 Earth switch in the outgoing (load) side	联锁装置 Interlock device	熔断器 Fuse	撞击式熔断器 Percussive fuse	电动分闸装置 Electric opening devices	
负荷开关 load switch	不带撞击熔断器 without striker	FN7-12	—	—	—	—	—	线路负荷开关 Line load switch
		FN7-12DSL	—	—	—	—	—	
		FN7-12DXL	—	—	—	—	—	
	带撞击熔断器 with striker	FN7-12R	—	—	—	—	—	变压器保护 Transformer Protection
		FN7-12 DSLR	—	—	—	—	—	
		FN7-12 DXLR	—	—	—	—	—	
带撞击熔断器 with striker	FN7-12RAF	—	—	—	—	—	变压器保护 Transformer Protection	
	FN7-12 DSLRAF	—	—	—	—	—		
	FN7-12 DXLRAF	—	—	—	—	—		

注：(-) 无 () 有 Notes: (-) available () available

概述 General

FN7-12DR型户内交流高压负荷开关是适用于交流50Hz, 额定电压12KV的三相交流电力系统中作为开断负荷电源及关合短路电流之用, 组合电器可开断直至短路电流的任何电流, 可作为保护之用。

FN7-12D type indoor load break switch is suitable for operating in the three-phase AC50Hz, rated voltage 12KV system, to break the power source and make short circuit current, the fuse switch can break the current up to rated short circuit level, as protective equipment.

使用环境 Normal service conditions

- 周围空气温度：上限：+40，下限：-25
- 海拔高度不超过1000m；
- 相对湿度：日平均值不大于95%，月平均值不大于
- 周围空气应不受腐蚀性或可燃性气体及水蒸气等明显污染；无经常性剧烈振动。
- Ambient air temperature: -25 ~+40，
- Altitude: 1000m;
- Humidity: Daily average value of relative humidity: 95% Monthly average value of relative humidity: 90%
- The ambient air is not significantly polluted by dust, smoke, corrosive and/or flammable gases, vapours or salt.

FN7-12

系列户内高压负荷开关及熔断器组合电器

Indoor AC high-voltage load switch and fuse combination

外形及安装尺寸 Dimensions



图1 无脱扣“先路”负荷开关
Figure 1 No “tripping” load switch

图2 无脱扣“变压器保护”负荷开关
Figure 2 No tripping “Transformer protection” load switch

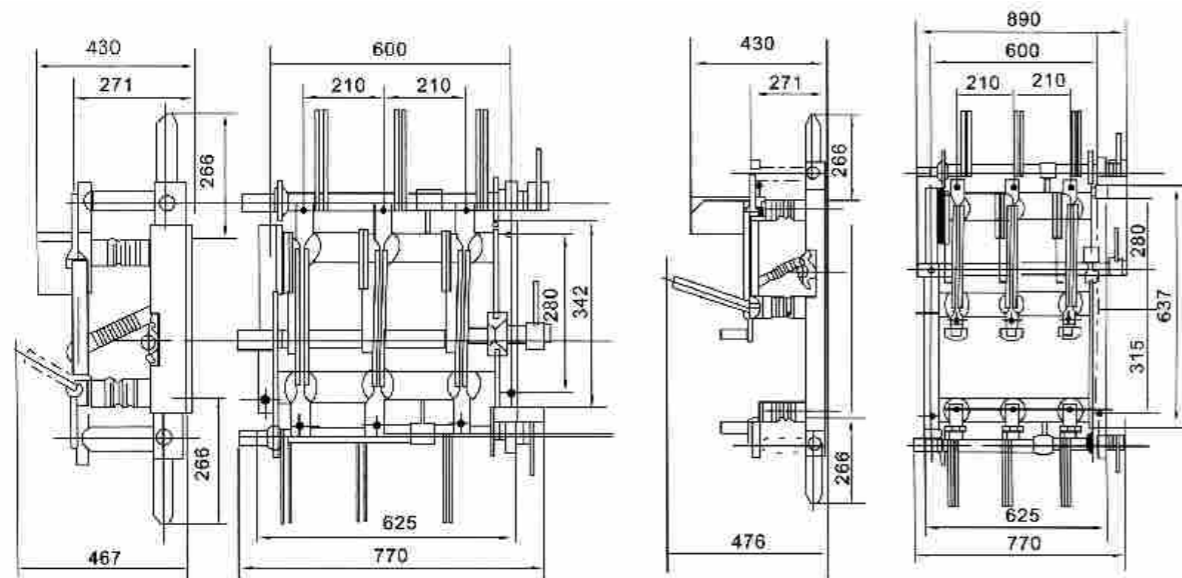

图3 脱扣器撞击负荷开关
Figure 3 “Release strike the load break switch

图4 CS6操作机构安装示意图
Figure 4 Assembly illustration of CS6 operating mechanism

FN5-12

系列户内高压负荷开关及熔断器组合电器

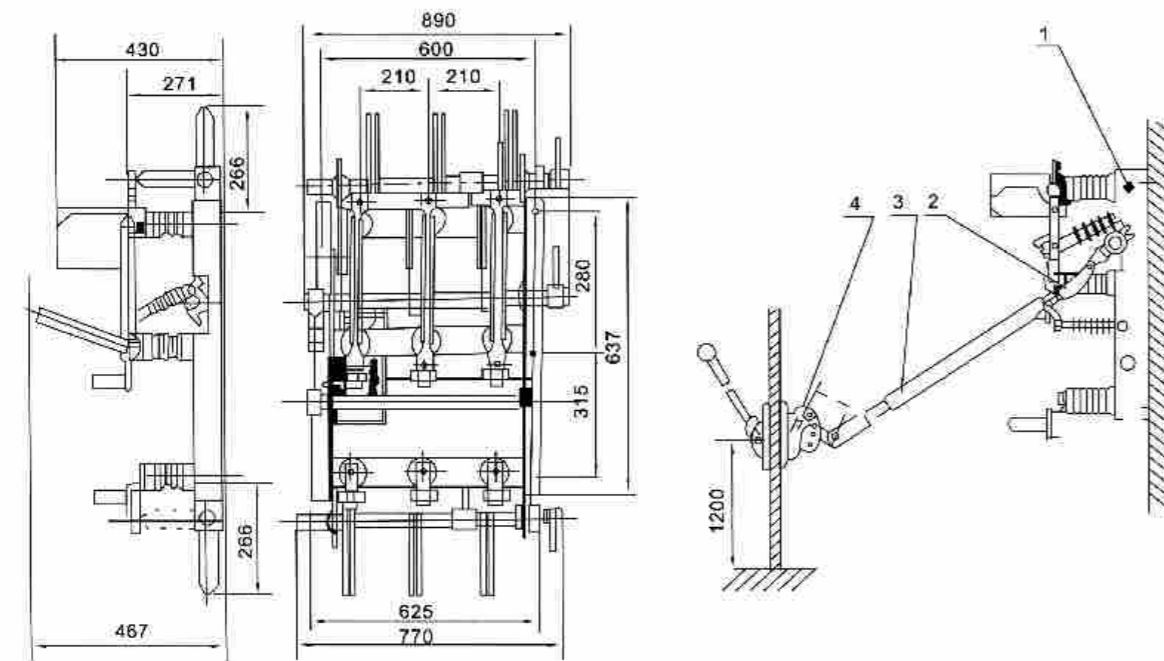
Indoor AC high-voltage load switch and fuse combination

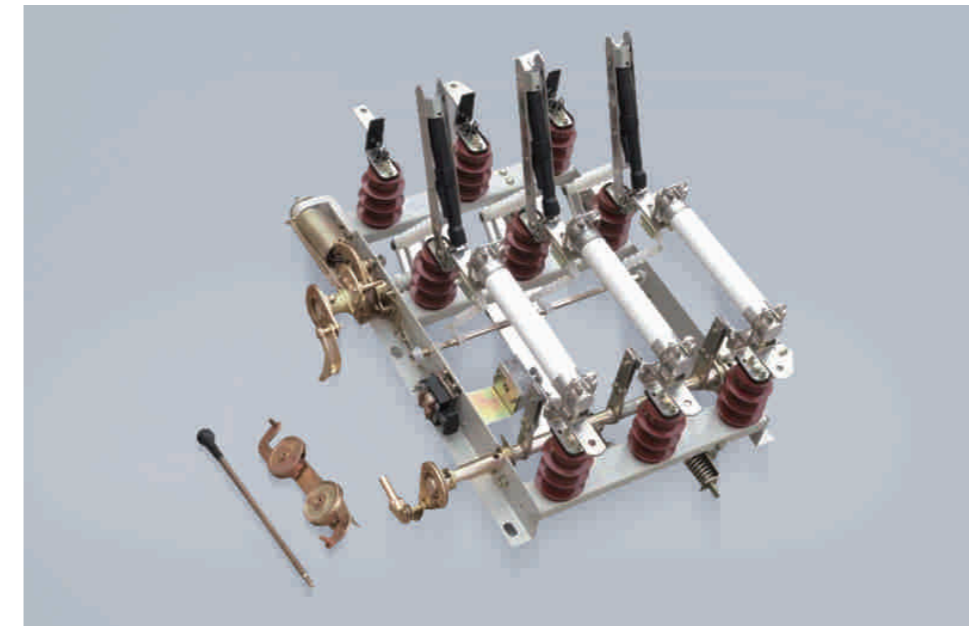

主要技术参数 Technical specifications

额定电压kV Rated voltage	1min工频耐压KV Frequency withstand voltage(1min)	额定电流A Rated current	4秒热稳定电流 Rated short time withstand current 4s	动稳定电流(峰值)KA Rated peak withstand current(peak)	额定开断电流A Rated short circuit breaking current	短路开合电流KA Rated short circuit making current
12	42	400	12.5	31.5	400	31.5
	48	630	20	50	630	50

熔断器额定参数 Fuse Ratings

型号 Type	额定电压KV Rated voltage	额定电流A Rated current	熔体的额定电流A Rated current of fuse body
SDLA*J	12	50	6,3,10,20,25,31,5,40
SFLA*J	12	100	50,63,71,80,100
SKLA*J	12	125	125

外形及安装尺寸 Dimensions

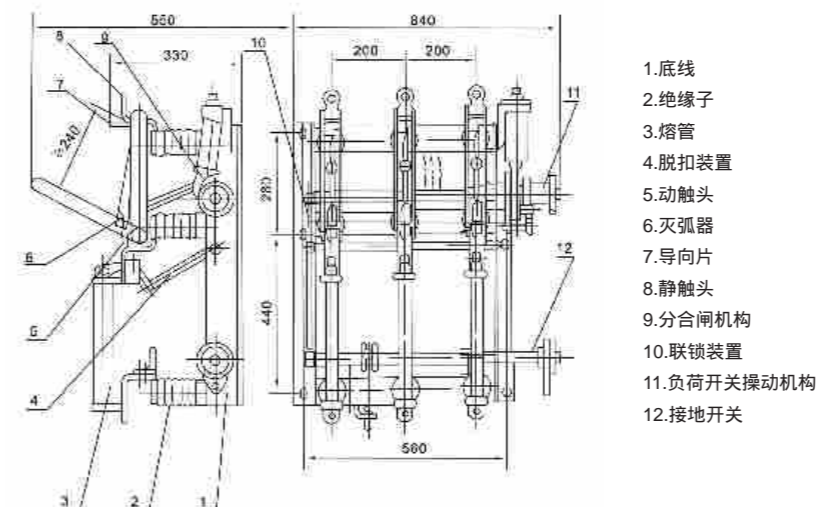

FN5-12R(L)户内交流高压负荷开关

概述 General

FN5-12R(L)型户内交流高压负荷开关-熔断器组合电器经全面型式试验和长期的试运行考核,性能达到IEC420 交流高压负荷开关-熔断器组合电流(1990版)和GB3804 3-63KV交流高压负荷开关标准要求,与国外同类产品比较,技术参数已达到同类产品水平,具有体积小,重量轻,可用于环网柜和箱式变电站,广泛应用于10KV线路电能的分配,可实现开关、隔离和接地三工位,并有效地避免了设备的缺相运行。

FN5-12R(L) Model indoor AC HV load break switch-fuse combination apparatus is developed and designed based on international technology and national power supply requirement, it passes all type tests and trial-operation inspections. The apparatus conforms to IEC62271-105: AC load break switch and fuse combination apparatus. (1990 edition) and GB3804: 3-63kV AC HV load break switch. Compare to international product, it keeps up with technical level with small volume and light weight. It is applicable in ring main unit and prefabricated substations as well as 10kV line and power distribution system. The product realizes three working positions: power making, power breaking and earth, and effectively avoid the downstream equipment operating under phase failure.

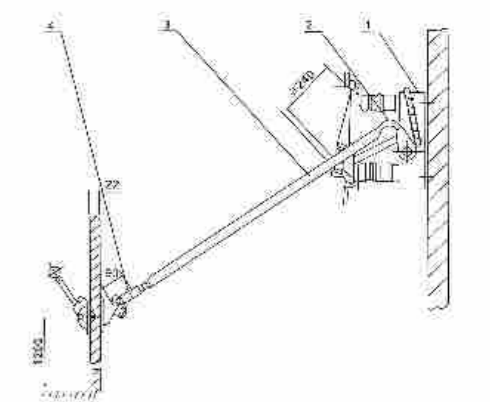

1.负荷开关 Load switch
2.弯连接 Bent connection
3.3/4焊接钢管 (用户备用) 3/4" welding steel pipe (provided by user)
4.操动机构 Actuator

负荷开关与CS6-1型操动机构联接安装图
Connection and assembly picture of load switch and CS6-1 operating mechanism

GN19-12

型系列户内高压隔离开关

Indoor high-voltage isolation switch



型号及含义 Type and meaning



使用环境 Normal service conditions

- 海拔不超过1000m; Altitude: 1000m;
- 周围空气温度: -25 ~+40 ; Ambient air temperature: -25 ~+40 ;
- 周围环境相对湿度: 日平均值不大于95% 月平均值不大于90%; Humidity: Daily average value of relative humidity: 95% Monthly average value of relative humidity: 90%
- 地震烈度不超过8度; Earthquake grade less than Degree 8
- 安装场所: 没有火灾,易燃,易爆,严重污秽,化学腐蚀及剧烈振动场所. The ambient air is not significantly polluted by dust, smoke, corrosive and/or flammable gases, vapours or salt.

主要技术参数 Technical specifications

型号 Type	额定电压 (KV) Rated voltage	额定电流 (A) Rated Current	4秒热稳定电流 (kA) Rated short time withstand current (4s)	动稳定电流 (kA) Rated peak withstand current
GN19-10(C)400-12.5	12	400	12.5	31.5
GN19-10(C)630-20		630	20	50
GN19-10(C)1000-31.5		1000	31.5	80
GN19-10(C)1250-40		1250	40	100

概述 General

GN19-12型系列户内高压隔离开关系高压开关设备,用于额定电压12KV,交流50Hz及以下电力系统中,配有CS6-1型人力操作机构,作为在有电压而无负载的情况下,分,合电路之用,亦有派生产品防污,高原型的和加装带电显示装置等。

GN19-12(C) indoor HV disconnect switch applies to power system of rated voltage below 12kV, AC 50/60Hz. It is equipped with CS6-1 manual-operating mechanism and is used to break and make circuit under no-load. There are additional pollution type, high-altitude type and voltage indicating type.

GW9

系列户外高压隔离开关

Indoor high-voltage isolation switch

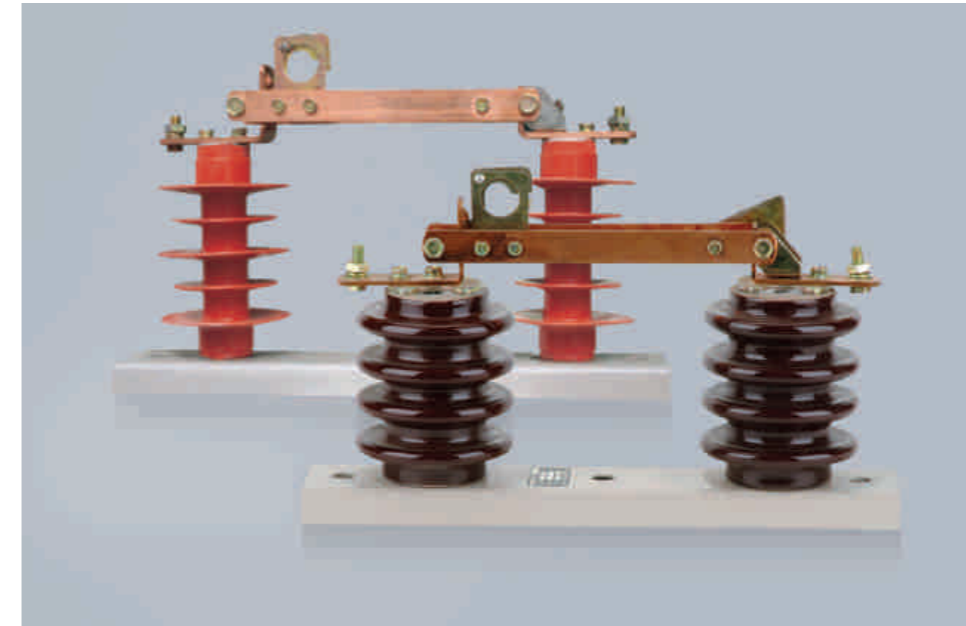

用途 Application

GW9-10G型户外高压隔离开关是单相交流50Hz高压开关设备,用于额定电流为12kV的电力系统中,作为电压无负载的情况下接通或隔离电源之用。

GW9-10G outdoor HV disconnect switch is of single phase AC 50Hz high voltage switch, used to operate in the power system of 12kV, to make and disconnect the power source in distribution line without load.

12kV

型号 Type	额定电压 (KV) Rated voltage	额定电流 (A) Rated Current	开断电流 (A) Breaking current	冲击电压 (BIL) Impulse voltage	工频耐压 (KV) Frequency withstand voltage	爬距 (mm) Creepage distances	重量 (kg) Weight	外形尺寸 (cm) Dimensions
GW9-10W/400	12	200	6300	100	42	350	3.8	42X35X11
GW9-10W/400	12	200	8000	110	42	350	3.8	

12kV

型号 Type	额定电压 (KV) Rated voltage	额定电流 (A) Rated Current	4S热稳定电流 (kA) Rated short time withstand current (4s)	动稳定电流 (kA) Rated peak withstand current	冲击耐压 (KV) Impulse withstand voltage		工频耐压 (KV) Frequency withstand voltage	
					相对地 (KV) To earth and between phases	断口间 (KV) Across the isolating distances	相对地 (KV) To earth and between phases	断口间 (KV) Across the isolating distances
HGW9-10W/400A	10	400	12500	31500	75	85	38	42
HGW9-10W/630A	10	630	12500	31500	75	85	38	42

HTDW2

型号 Type	额定电压 (KV) Rated voltage	额定电流 (A) Rated Current	4S热稳定电流 (kA) Rated short time withstand current (4s)	动稳定电流 (kA) Rated peak withstand current	冲击耐压 (KV) Impulse withstand voltage		工频耐压 (KV) Frequency withstand voltage	
					相对地 (KV) To earth and between phases	断口间 (KV) Across the isolating distances	相对地 (KV) To earth and between phases	断口间 (KV) Across the isolating distances
GTDW2	0.5	800	1250	3150	4	5	2	3
GTDW2	0.5	1000	1250	3150	4	5	2	3

GWR1

型号 Type	120A	150A	220A	300A	360A	470A	600A
GWR1	0.15	0.20	0.30	0.50	0.60	0.50	0.90
GWR1	80	100	150	180-2	250	315-320	400

使用环境 Normal service conditions

- 海拔高度不超过1000m;
- 周围空气温度: 上限40 , 下限一般地区 -30 , 高寒地区 -40 ;
- 风压不超过100Pa;
- 地震烈度不超过8度;
- 无频繁剧烈震动的场所;
- 普通型安装所应无严重影响隔离开关绝缘和导电能力的气体、蒸气、化学性沉积、盐雾、灰尘、及其它爆炸性、侵蚀性物质;
- 防污型适宜于重污秽地区, 但不应有引起火灾及爆炸物质。
- Altitude: 1000m;
- Ambient air temperature: Maximum air temperature: +40 , Minimum air temperature: -15 ; Alpine region : -40
- Pressure does not exceed 100Pa
- Earthquake grade less than Degree 8
- Humidity: Daily average value of relative humidity: 95% Monthly average value of relative humidity: 90%
- The ambient air is not significantly polluted by dust, smoke, corrosive and/or flammable gases, vapours or salt.

备忘录 REMARK

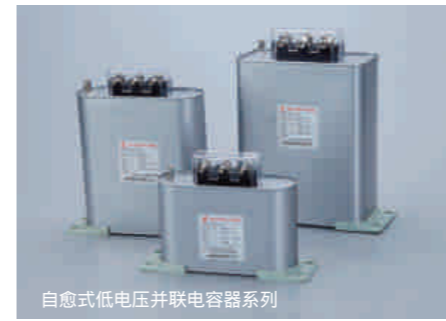

自愈式低电压并联电容器系列

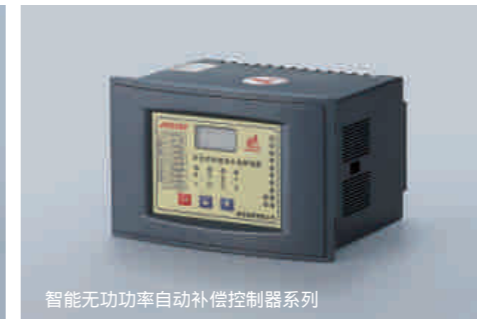

智能无功功率自动补偿控制器系列



智能复合开关系列



交流高压真空接触器系列



低压无功就地补偿装置(静型)系列



高压无功柱上自动补偿装置系列



DDS450 系列单相电子式电能表



DSSD450 系列三相电子式多功能电能表



DT/SS(X)450 系列三相电子式有功无功组合电能表



ZMM 系列 D 导轨式电能表



ZM 系列数显电流表



LMK 系列电流互感器

欢迎您索取指明集团
其它系列产品目录详细信息或登陆官网
www.zmgs.com